



DUKERS
Quality Commercial Refrigeration

Item # _____

Qty # _____

Model # _____

Project # _____



**Stock Pot
DCSPA2**



Knobs

Cast Iron
Cooking Surface



Catch Tray



Ventilation



Legs



PRODUCT DESCRIPTION

- Stainless steel sides and front valve cover.
- Stainless steel tubing for pilots and pilot tips per burner ring.
- Heavy duty cast iron three-ring burner, rated at a total of 160,000 BTU/h.
- Each burner is equipped with two continuous pilots.
- Heavy duty cast iron and top grates.
- Two manual controls to operate the inner and outer rings independently.
- 3/4" NPT rear gas connection and regulator standard.
- Stainless steel legs standard.
- Full length seamless drip pan for easy cleanup.



**HIGH QUALITY
STAINLESS STEEL &
ROBUST DESIGN**

STOCK POT MODEL	DIMENSION		
	Width	Depth	Height
DCSPA2	18 in	42 1/4 in	22 3/4 in



Los Angeles | San Francisco | Dallas
Houston | Florida | Chicago | New Jersey

1-800-931-8628

info@dukersusa.com

www.DukersUSA.com

DETAILS & SPECIFICATIONS

STOCK POT DCSPA2

Front View

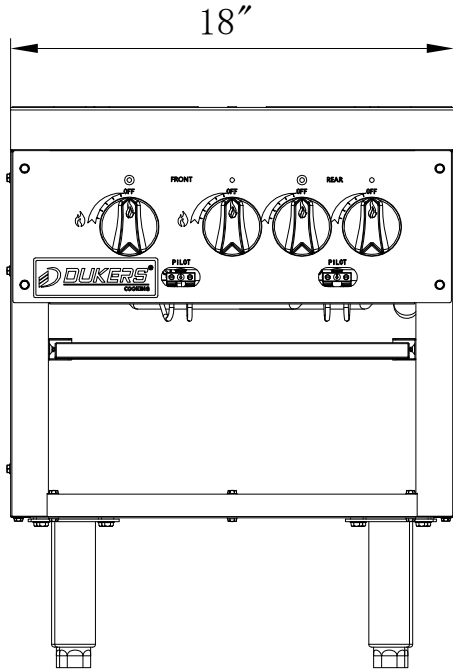

Top View

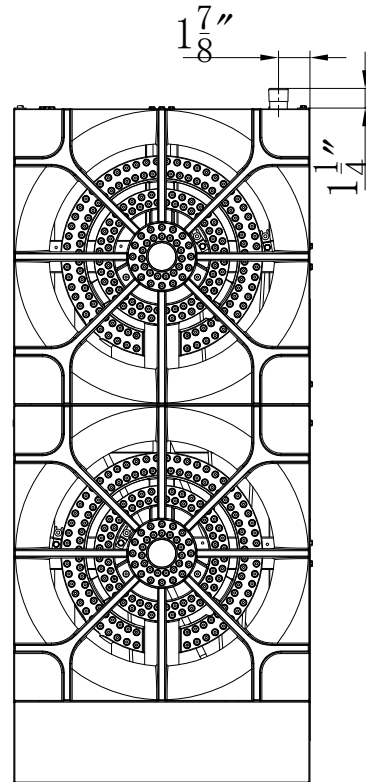

Side View

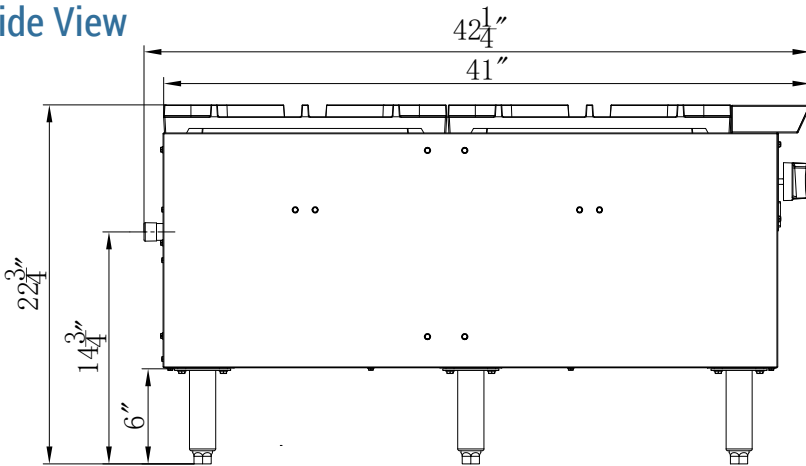

DCSPA2

GAS SOURCE	NG/Propane
COOKING AREA	18X41 in
BURNER	4 count
SINGLE BURNER	40000 BTU/H
COMBINED	160000 BTU/H
GAS PRESSURE	NG: 5 "WC Propane: 10 "WC
NOZZEL	NG: 32# Propane: 48#

Model	Packaging Dimensions (inches)			Net Weight (lbs)	Ship Weight (lbs)	Container Capacity 40'HQ
	W	D	H			
DCSPA2	21 1/8"	55 1/2"	24"	224	310	132



Los Angeles | San Francisco | Dallas
Houston | Florida | Chicago | New Jersey

1-800-931-8628

@ info@dukersusa.com

www.DukersUSA.com