



PROJECT

ITEM NO:

QUANTITY:

Equipment Filler Table

FEATURES & CONSTRUCTION:

- Top is fabricated with 1-1/2" rounded front edge and 1-1/2" high backsplash with flat edges at both ends.
- Table front edge and both ends formed with hemmed edge to provide extra rigidity and safe to touch finish.
- Reinforced table top with two stainless steel sound deadening hat channels. Note: Three sound deadening hat channels on 30" & 36" deep tables.
- Adjustable stainless steel cross-bars with aluminum die cast fittings to secure cross-bars to legs for added stability.
- All exposed welded areas smooth polished to brush finish sanitary #4.
- Welded stainless steel leg sockets with two point leg fastening.
- All tables shipped K.D., but easily assembled.



NSF STD.2
Certified

MATERIAL:

Top: 18 Gauge Stainless Steel - 400 series

Leg: 1-5/8" Stainless Steel Tubing with 1" Adjustable Stainless Steel Bullet Feet

Cross-Bar: 1-1/4" Stainless Steel Tubing



MODEL#	SIZE		
	D	L	H
SMEFT-2412	24"	12"	36"
SMEFT-2415		15"	
SMEFT-2418		18"	
SMEFT-3012	30"	12"	
SMEFT-3015		15"	
SMEFT-3018		18"	
SMEFT-3612	36"	12"	
SMEFT-3615		15"	
SMEFT-3618		18"	

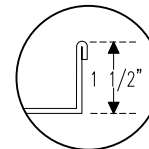

1-1/2" High
Backsplash on Rear

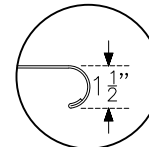

Rolled Rim
Front Edge
Reinforced with
Hemmed Edge

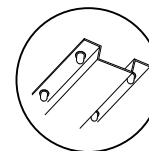

Two (three on 30" & 36"
deep) Hat Channel
Reinforced Top.
Attached to Underside
of Top via Studs Welded
to Underside of Top,
Adhesive and Stainless
Steel Acorn Nuts.



Aluminum Die Cast
Fitting For Adjustable
Cross-Bar



1" Adjustable
Bullet Feet



Rev. 01/21

SAPPHIRE MANUFACTURING
Tel: 718-543-2111
Fax: 718-543-2121

info@sapphiremanufacturing.com
WWW.SAPPHIREMANUFACTURING.COM



PROJECT

ITEM NO:

QUANTITY:

Equipment Filler Table



NSF STD.2
Certified

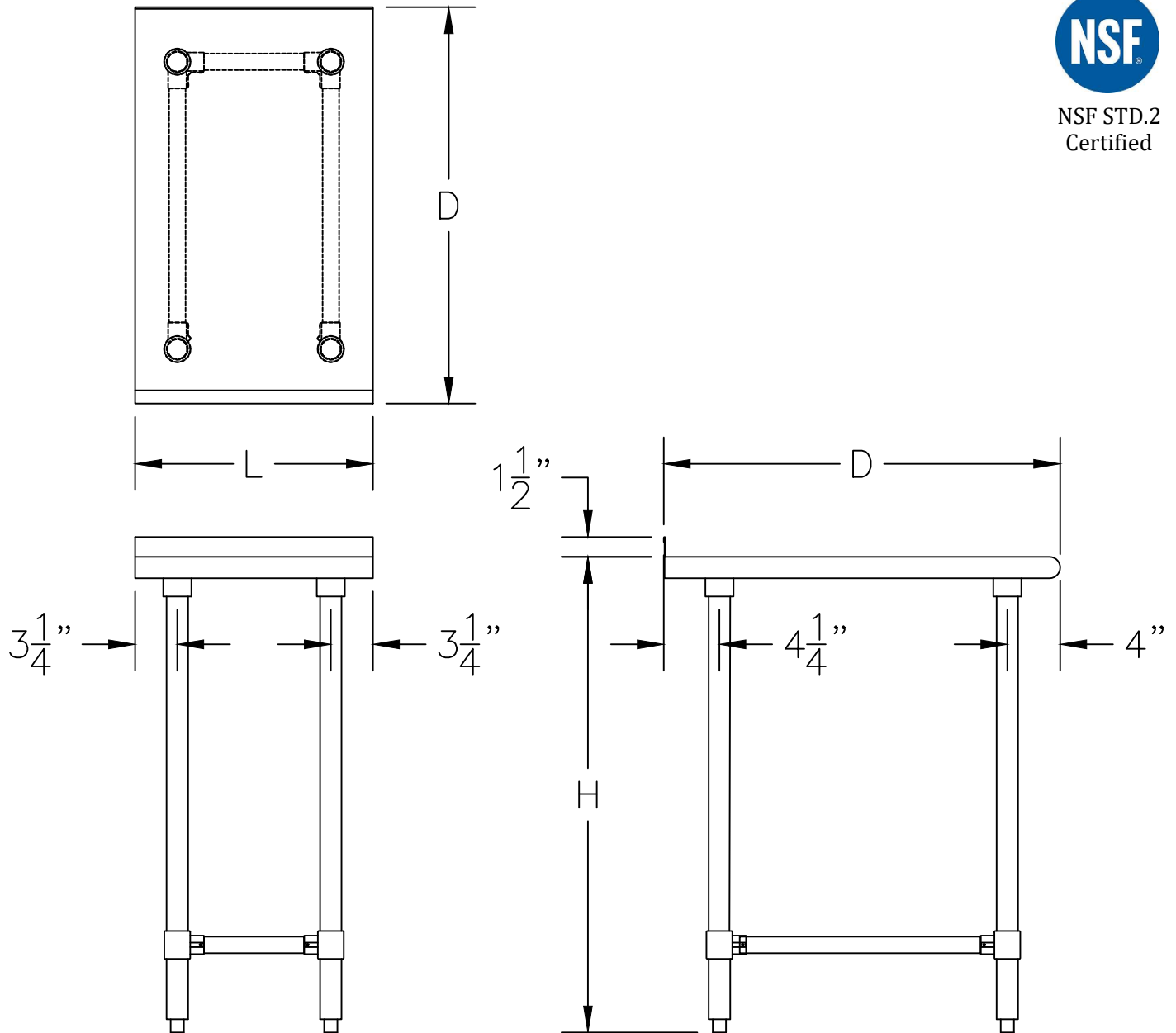

Specifications subject to change without notice.

All dimensions are typical (Tolerance 1/2").



Rev. 01/21

SAPPHIRE MANUFACTURING
Tel: 718-543-2111
Fax: 718-543-2121

info@sapphiremanufacturing.com
WWW.SAPPHIREMANUFACTURING.COM