



AMERICAN RANGE

A **HATCO** COMPANY

Project _____

Item # _____

Quantity _____

AF-50/25 TUBE FRYER

GAS TYPE: NATURAL LP



AF-50/25

STANDARD FEATURES

- All stainless steel front and sides
- (1) 50 lb. capacity stainless steel tank 14" x 14" frying area
- (1) 25 lb. capacity stainless steel tank 6 3/4" x 14" frying area
- Burners rated at 40,000 BTU/hr. each
- Special alloy metal diffuser located in the burner tube for better heat transfer
- Millivolt control system with 100% safety shut off
- Thermostatic control with 200° F to 400° F range
- 1-1/4" full port drain valve
- 6" legs or optional casters
- Three baskets with plastic coated handles
- Two year limited warranty, parts, and labor
- Five year limited (prorated) warranty on stainless steel tank

AVAILABLE OPTIONS

- Stainless steel tank cover
- Four casters front two with locking brakes
- Stainless Steel Splash Guard
- Quick disconnect and flexible gas hose
- Joiner Strip: Connects two fryers and prevents oil from getting in between the fryers or drain station



Model Shown AF-50/25

Shown with optional casters

DESCRIPTION

American Range, 50/25 pound fryer, Model AF-50/25. All stainless steel front and sides, with heavy gauge stainless steel tanks and rated at 40,000 BTU/hr. AF-SO fryer tube fryer equipped with 3 burners and a AF-25 fryers equipped with two burners. Unit has one 50 pound capacity tank and one 25 pound capacity tank. Includes three fry baskets with plastic coated handles. Standard Millivolt control system with 100% safety shut off and Thermostatic control with a temperature range of 200°F to 400°F. 1-1/4" full port drain valve for easy cleaning.



DESIGNED & BUILT IN USA
PROFESSIONAL COOKING EQUIPMENT

A70390 Rev B 03242025



AMERICAN RANGE

A **HATCO** COMPANY

13592 Desmond St Pacoima CA 91331
T. 818.897.0808 Toll Free: 888.753.9898
www.AmericanRange.com

AF-50/25 TUBE FRYER

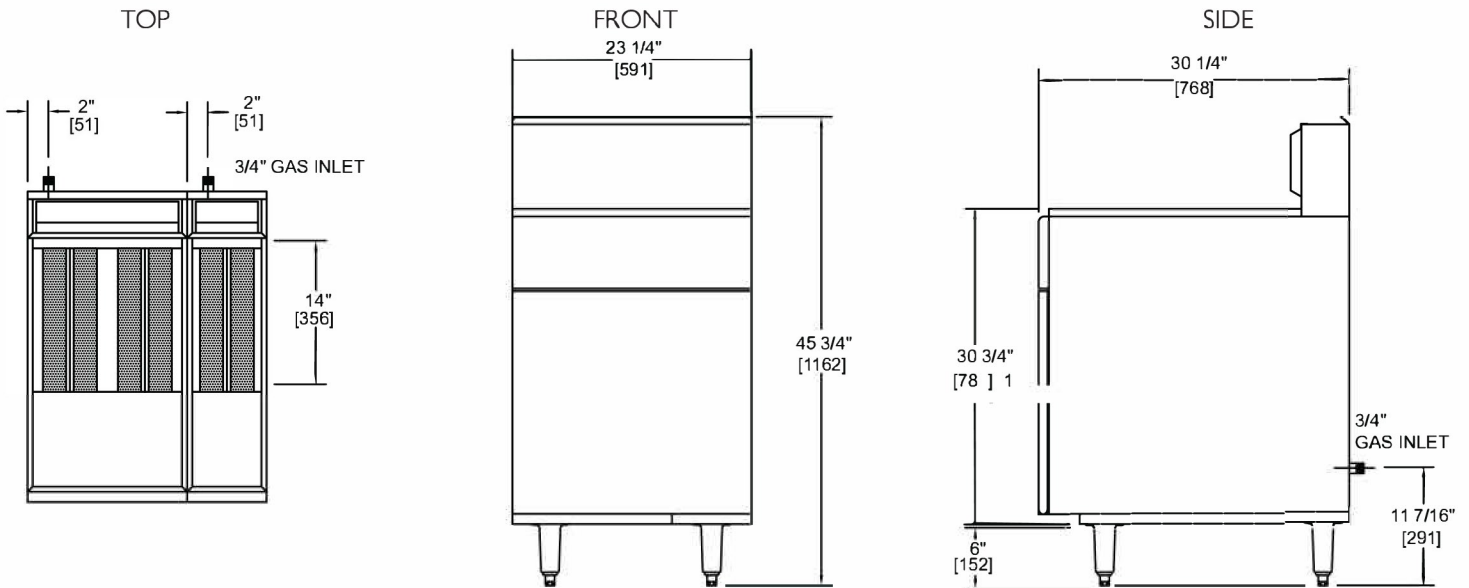

MODEL	WIDTH (MM)	DEPTH (MM)	HEIGHT (MM)	BURNERS	COOKING AREA	BTU/hr.	(kW)	Shipping Weight*	
								LBS	(KG)
AF-50/25	23 1/4" (591 mm)	30-1/4" (768 mm)	45-3/4" (1162 mm)	5	(1) 14" x 14" (356 mm x 356 mm) (1) 8-3/4" x 14" (171 mm x 356 mm)	200,000	(59)	225	(102)

Specify type of gas and altitude if over 2000 feet.

Please specify gas type when ordering.

NATURAL GAS	MANIFOLD PRESSURE	
	PROPANE GAS	MANIFOLD SIZE
5.0" W.C.	10.0" W.C.	3/4" (19MM)

*Shipping weight includes packaging and is approximate.

American Range is a quality manufacturer of commercial cooking equipment. Due to continuing product improvements, these specifications are subject to change without prior notice.

COMBUSTIBLE WALL CLEARANCES:

For use only on non-combustible floors. Legs or casters are required, or 2" (51) overhang is required when curb mounted. Clearance from non-combustible walls is 0". When unit is placed next to combustible walls, clearances must exceed 12" (305) from sides, and 4" (102) from rear.

Commercial cooking equipment requires an adequate ventilation system. For additional information, refer to the National Fire Protection Association's standard.

NFPA96 "Vapor Removal from Cooking Equipment" (NOTE: For North America only)

