



The Legacy Companies
 3355 Enterprise Avenue, Suite 160, Fort Lauderdale, FL 33331
 Sales: (954) 202-7419 • Sales@TheLegacyCompanies.com

Project Name: _____
 Location: _____
 Item #: _____ Qty: _____
 Model: _____

BB-2016

SILVER SAVER BURNISHER (1 HP)

The Blakeslee Silver Saver is the only burnishing unit that will restore luster and brightness to stainless-silver tableware. Special porcelain-ceramic burnishing media and chemical compound makes it possible to restore luster and brightness to stainless steel flatware, hollow ware, aluminum ware, pewter and silverware. So it looks just like new!

Before



After



FEATURES

- Open-top design for easy loading and unloading
- Porcelain-Ceramic Media 1/3 the weight of steel balls
- Light weight permits burnishing of hollow ware
- No peening effect on stainless steel or silver
- Produces high luster
- Quiet operation
- No external plumbing
- Casters 4" (100mm) ball-bearing swivel casters with 1 locking caster

FRAME

- Fully-Welded CRS Tubing, Primed & Painted Epoxy
 - 1.5" (38mm) X 1.5" (38mm)

TUB

- Seams Fully-Welded CRS Tubing, Primed & Painted Epoxy
 - 11 gauge (3mm) CRS
 - .375 (10mm) Cast Polyurethane lining with Molded drain

SKIRT and COVER

- Plastic 125 ABS

MOTOR

- 1HP-115V single phase
- 15AMPS
- Class-A Constant Duty 104°F/40°C
- 3450 RPM
- Drive Pulley 3.5" (89mm) x .5" (13mm)

COMPOUND TANK and PUMP

- Molded Plastic
- Tank Capacity: 2gal (7.6L)
- Pump: P:AAA(Constant) 6GPH- 23L/H

BEARING and ECCENTRIC SHAFT

- Shaft 1" (25mm) with double spherical roller bearings
- 2.25" (70mm) x .75"(19mm) driven pulley

NOISE LEVEL

- Less than 85 dba

BURNISHING MEDIA

- Pure porcelain ceramic media, non-rusting
- 1/3 the weight of steel balls, eliminates peening on hollowware
- Media will last life of machine with approximate loss of 5% per yr.

BURNISHING COMPOUND

- Safe for Brass, Silver and Stainless steel
- De-tarnishing soaking is not necessary

OPERATING TECHNIQUE

- Fill tank with proper amount of water and burnishing compound
- Unit is ready for days operation no further attention required.
- Flatware should be "dishwashing cleaned" before placing in unit
- Rewash flatware after burnishing

OPERATING TIME

- Less than 10 mins

Due to periodic changes in designs, methods, procedures, policies and regulations, the specifications contained in this sheet are subject to change without notice. While we exercise good faith efforts to provide information that is accurate, we are not responsible for errors or omissions in information provided or conclusions reached as a result of using the specifications. By using the information provided, the user assumes all risks in connection with such use.

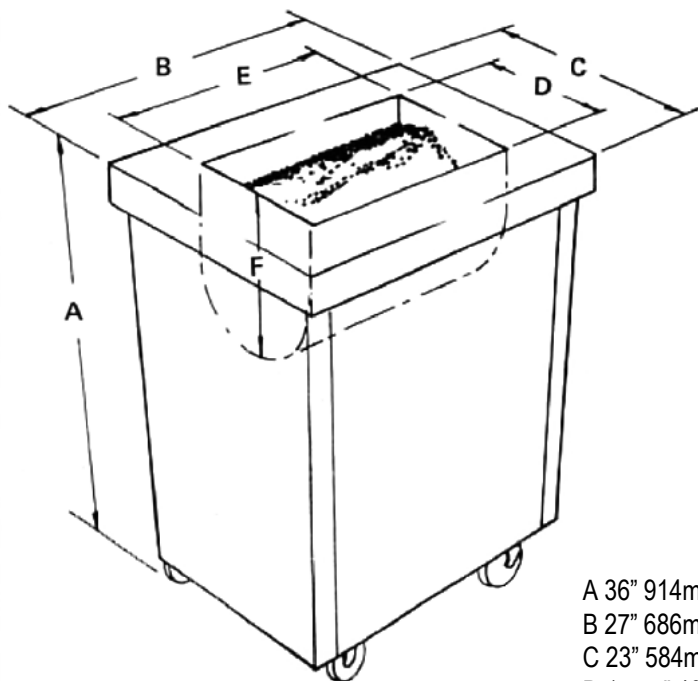
SILVER SAVER BURNISHER (1 HP)

A 36" 914mm
B 27" 686mm
C 23" 584mm
D 15.75" 400mm
E 20" 508mm
F 16" 406mm

APPROXIMATE SHIPPING SPECIFICATIONS

Dimensions	33.5in x 28in x 46in	851mm x 660mm x 1168mm
Cube	23.5ft	0.665m ³
Total Machine Weight	455lbs	206kg
Machine	265lbs	120kg
Media	160lbs	72kg
Compound Bottles	1 pint	0.48L
		Quantity (2)

ELECTRIC

115V- 60 cycle current
Grounded cord and plug

WARRANTY

1 year: defective material and workmanship
3 year: Tub lining coarse