



**AMERICAN EAGLE**<sup>®</sup>  
**FOOD MACHINERY, INC.**

**AE-PS01**  
**Countertop**  
**Dough Roller**

773.376.0800 (P) • 773.376.2010 (F) • 3131 S. Canal St. Chicago, IL 60616

*Enhance The Efficiency Of Your Operation With An American Eagle® Dough Roller!*  
**Quality Construction, Competitive Pricing, And Reliable Support Lower Your Total Cost Of Ownership!**

## Quality Design

- Powerful 1 HP Motor
- Durable 100% Gear And Chain Driven Transmission
- Extra Heavy Gauge Steel Frame And Housing
- Heavy Duty Stainless Steel Rollers And Trays
- Enamel Clear Layer Coated White Finish Resists Rust, Scratches, And Dents
- Compact Footprint Fits Countertops Or Mobile Carts
- Back Panel Lifts Open To Allow Easy Cleaning Of Rollers



### 1st Pass



### Get Consistent Results Every Time With An Easy To Use Dual Pass System!

- Dough Ball Feeds Into Top Chute
- Elongated Dough Comes Out, Then Passed To Middle Tray
- Finished Product Comes Out Ready To Use
- **Great For Pizza, Focaccia, Roti, Calzones, Dessert Pie Crusts, Flour Tortillas, Pita Bread, Pasta, And More**

## Standard Features

- Ergonomically Friendly, Front Mounted Feed Chutes, Output Trays, And Buttons
- Push Button Start, Emergency Stop Switch, Automatic Safety Shutoff
- Convenient Side Mounted Roller Adjustment Levers
- Thermal Overload Protection Helps Protects Motor
- 1 Year Limited Warranty\*

### 2nd Pass



Proud Member of:  
  
 North American Association of  
 Food Equipment Manufacturers

**Quality • Value • Reliability**



**AMERICAN EAGLE**<sup>®</sup>  
**FOOD MACHINERY, INC.**

**AE-PS01**  
**Countertop**  
**Dough Roller**

sales@ameagle.biz • www.americaneaglemachine.com

***Our Dough Roller Helps Pizzeria And Restaurant Operators Save Time, Training, And Labor Costs. Within Seconds, Employees Can Make Uniform Products Without Having Expertise In Hand Tossing, Slapping, Or Rolling A Dough Ball. Our Machines Are A Time Saving Solution For Any Operation With High Volume Needs Or Challenged With Employee Turnover!***

**Specifications**

Model	Productivity**	Max Output Diameter	Motor	Voltage V/HZ/PH	Amp	Transmission	Safety Switch	Roller Size	Adjustable Thickness Range
AE-PS01	400-600 Pieces/Hour	18 in	1 HP	115 / 60 / 1	14	Chain Driven	Yes	3.5" Dia	0.04 to 0.7in 1mm to 18mm

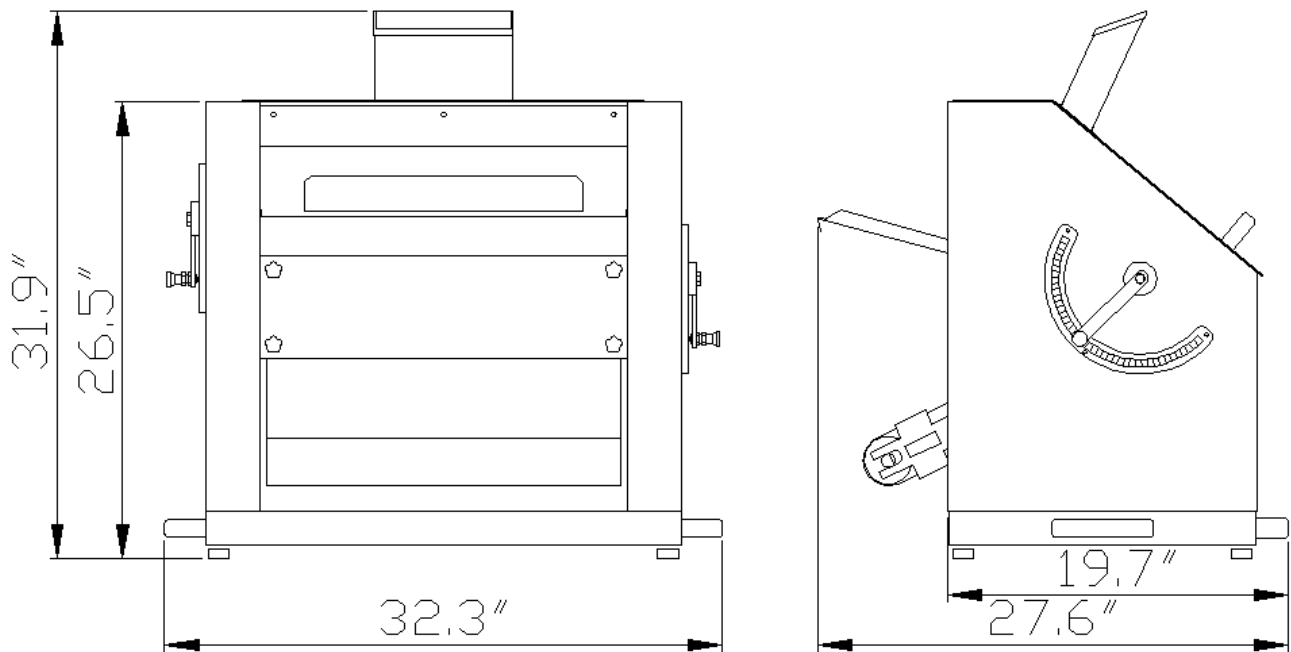

**Dimensions and Shipping Information**

Model	Overall Dimensions	Roller Dimension	Net Weight	Shipping Dimensions***	Ship Weight	Freight Class
AE-PS01	32.3"L x 27.6"W x 31.9"H	3.5"W x 18.5"L	298 lbs	35.7"W x 32.2"L x 38.04"H	386 lbs	85

\* Warranty must be registered. Please see full warranty statement for details on coverage

\*\* Estimated from continuous operation

\*\*\* Crates are affixed to a skid (pallet). The weight and dimensions of this skid are included above and may vary from shipment to shipment.



**Quality • Value • Reliability**