



Profit from the Eagle Advantage®

Specification Sheet

Short Form Specifications

Eagle Slicer Table, model _____.
14 gauge type 304 stainless steel tabletop features box marine edge to retard spillage. Heavy gauge stainless steel construction. Stainless steel legs. Stainless steel five-pan slides mounted to removable angle. Welded bottom solid shelf. Mobile unit features 5"-diameter heavy duty resilient casters, two with brake.



#T3030SEM-ST

Item No.:	_____
Project No.:	_____
S.I.S. No.:	_____

Slicer Tables

MODELS:

- T3030SEM-ST
- T3030SEM-ST-CAH

Design and Construction Features

- uni-lok® gusset system (patent #5,165,349): gusset is recessed into hat channel underside tabletop, reducing lateral movement.
- 14 gauge type 304 stainless steel tabletop with box marine edge on all four sides.
- 600-lb. (272.2 kg) total weight capacity—evenly distributed static load.
- Stainless steel five-pan slides mounted to a removable angle—accommodates 18" x 26" (457 x 660mm) sheet pans.
- 4½" (114mm) slide spacing.
- Welded bottom solid shelf.
- Stainless steel legs.
- Model #T3030SEM-ST features stainless steel bullet feet.
- Model #T3030SEM-ST-CAH features 5" (127mm)-diameter heavy duty resilient-tread swivel casters—two with brake.

EAGLE GROUP
100 Industrial Boulevard
Clayton, DE 19938-8903 USA
Phone: 302-653-3000 • 800-441-8440
Fax: 302-653-2065
www.eaglegrp.com • www.eaglemhc.com

For custom configuration or fabrication needs, contact our **SpecFAB® Division**.
 Phone: 302-653-3000 • Fax: 302-653-2065 • e-mail: quotes@eaglegrp.com





Item No.: _____
 Project No.: _____
 S.I.S. No.: _____

Slicer Tables

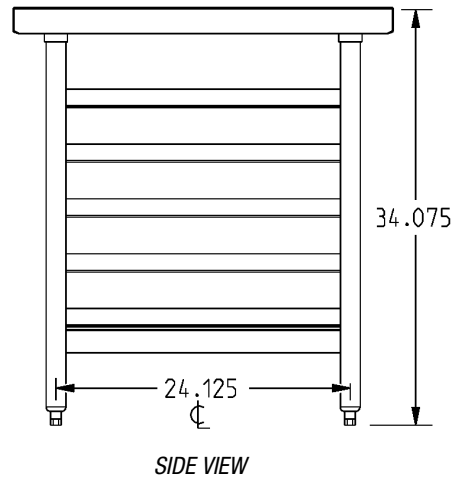
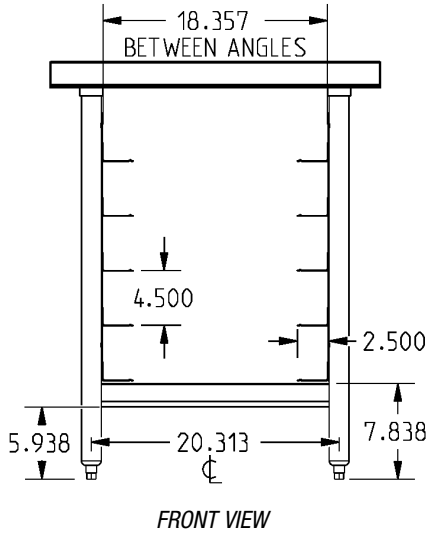
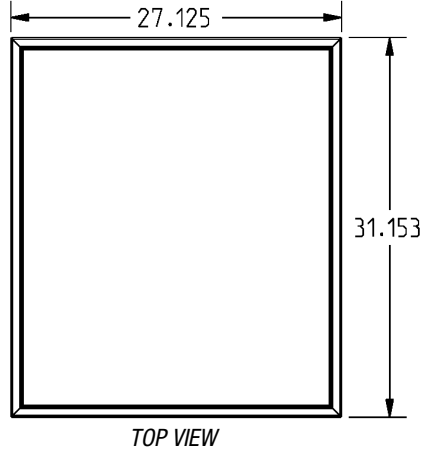

width		length		height		weight		Stationary	Mobile *
in.	mm	in.	mm	in.	mm	lbs.	kg	model #	model #
31 1/8"	791	27 1/8"	689	34"	864	95	43.1	T3030SEM-ST	T3030SEM-ST-CAH

* Features 5" (127mm)-diameter heavy duty resilient-tread swivel casters—two with brake.

EAGLE GROUP
 100 Industrial Boulevard, Clayton, DE 19938-8903 USA
 Phone: 302-653-3000 or 800-441-8440 • Fax: 302-653-2065
 www.eaglegrp.com • www.eaglehmc.com

Printed in U.S.A.
 ©2022 by Eagle Group
 Rev. 06/22

Spec sheets available for viewing, printing or downloading from our online literature library at www.eaglegrp.com

Although every attempt has been made to ensure the accuracy of the information provided, we cannot be held responsible for typographical or printing errors. Information and specifications are subject to change without notice. Please confirm at time of order.