



Certified to NSF Standard 2

SA 100
SA 130
SA 150
SA 180



Manual patty presses



- Polished, anodized aluminum body
- Stainless steel press assembly removed easily for cleaning
- Even in thickness patty forming for uniform cooking from edge to center
- Mold 4" (3 1/2 to 5 oz.), 5" (5 to 8 oz.), 6" (10 to 14 oz.) 7", (12 to 16 oz.) patties.
Thickness depends upon quantity of product placed in the press.
- Come with a supply of wax paper in the upper receptacle
- Last a lifetime for their simple, easy to clean design.

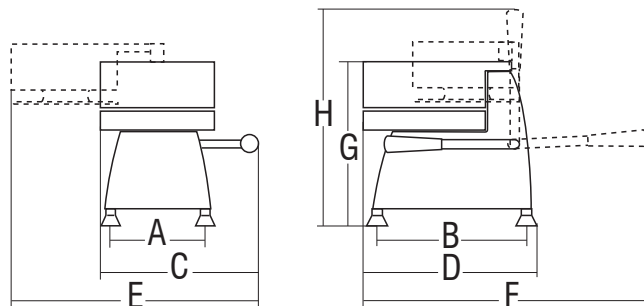

	Mold diameter	A	B	C	D	E	F	G	H	Net weight	Shipping	Gross weight
	inch.	inch.	inch.	inch.	inch.	inch.	inch.	inch.	inch.	lbs.	inch.	lbs.
SA 100	4"	5 1/2"	9 1/8"	10 1/16"	10 5/8"	12 3/16"	14 15/16"	10 1/4"	12 5/8"	10	16" x 15" x 14"	12
SA 130	5"	5 1/2"	9 13/16"	10 1/4"	12 3/16"	14 3/16"	18 1/8"	10 13/16"	14 3/16"	13	16" x 15" x 14"	15
SA 150	6"	5 1/2"	10 1/4"	10 1/4"	13"	14 15/16"	18 1/8"	10 13/16"	14 3/16"	14	16" x 15" x 14"	16
SA 180	7"	5 1/2"	10 1/4"	10 7/16"	13"	16 15/16"	19 15/16"	10 13/16"	14 3/16"	15	16" x 15" x 14"	18

