

MODEL: IMD-NEC501RV
IMD-NEC501FV

MERCHANDISER SLIDING DOOR



GENERAL FEATURES

- ✓ **Higher energy efficiency.** R290 refrigerant with electric fans, LED lighting and evaporative tray without electric resistances.
- ✓ **Sanitation.** Our units feature a hygienic design with rounded corners that have a large radius, making them easy to clean. Additionally, the shelves and runners inside the display can be quickly removed for thorough interior cleaning. Each unit is equipped with a trap at the bottom to facilitate cleaning.
- ✓ **Doors.** Self-closing door system features a permanent pressure mechanism, ensuring a secure closure every time. Additionally, a convenient 'stay open' feature engages when the door remains open at 95 degrees or beyond. Our doors also include triple chamber door gaskets that are easy to remove and snap in, ensuring an effective seal. Plus, for added flexibility, our doors are field reversible, allowing for easy installation and use in a variety of settings.
- ✓ **Control System.** Our temperature management system offers unparalleled precision, allowing for highly accurate temperature settings. With greater flexibility in adjusting temperature ranges, our system can be tailored to meet the unique needs of each end user. This ensures optimal performance and maximum satisfaction with every use.
- ✓ **Lighting.** LED lighting in the canopy and cabinet sides reduces the energy consumption by 80% to 90% compared to a traditional bulb, better light quality.
- ✓ **100% Tested.** All condenser units are 100% tested, in helium chambers for refrigerant leak detections.
- ✓ **Certified.** Audited and Certified by INTERTEK for compliance with UL 471 and NSF 7.



Revision:02 Date: 14/04/2023 IMD-NEC501RV_FV

ETL LISTED TO UL471 STANDARD AND SANITATION CLASSIFIED TO NSF7 – WE RESERVE THE RIGHT TO CHANGE SPECIFICATIONS WITHOUT PRIOR NOTICE

MODEL: **IMD-NEC501RV**

MERCHANDISER SLIDING DOOR

STANDARD FEATURES

➤ **Exterior**

- Plastic – coated steel, white.
- Completely injected compact structure.

➤ **Interior**

- Plastic- coated steel. White.
- LED lighting.
- Internal drain.

➤ **Door**

- Pivot door.
- Self – closing door with stay open feature.
- Stainless Steel covered hinges.
- Triple chamber snap in door seals for easy removal.
- Field reversible door (hardware needed).
- Door locks provided.
- Double pane glass door, tempered and low-e.

➤ **Insulation**

- CFC- Free polyurethane insulation, entire cabinet structure is foamed-in using a high-density polyurethane insulation.
- Low GWP & Zero ODP effect.

➤ **Shelving**

- (5) Five plastic coated extra – dense wire shelves.
- Set of Stainless Steel rails per shelf included.
- Dimensions WxD: 20-7/8” x 18-1/8” (530 x 460 mm).

➤ **Refrigeration**

- Digital temperature controller with automatic defrost system.
- Evaporative pan.
- Evaporator coil coated with anti-corrosion material.
- **Refrigeration capacity:**
 IMD-NEC501RV – 1990 Btu/h(14°F)/ 583W (-10°C).
 IMD-NEC501FV - 2120 Btu/h(-22°F)/ 621W (-30°C).

➤ **Electrical**

- Cord and NEMA 5-15P plug,
- Electrical connection is 115V / 1ph / 60 Hz.
- 20 AMP breakers required.



➤ **ETL Listed to UL471 Standard and Sanitation classified to NSF7.**

OPTIONAL FEATURES

- ✓ Stainless Steel wire shelf.
- ✓ Additional slide kits.
- ✓ Set of 6” legs, height adjustable from 5” to 8”.
- ✓ Electrical connection is 230 V / 1 ph / 50 Hz (Plug type and consumption varies).

MODEL: IMD-NEC501RV

MERCHANDISER SLIDING DOOR

Model	Dimensions (inches) (mm)			Doors	Shelves	Ref.	Ref.Weight (Lbs.) (gr.)	Temperature Range (°F) (°C)	Cond. Unit (H.P)	Capacity (Cu.Ft.) (L)	Case Amps 115V	Net weight (Lbs.) (Kg.)
	W	D	H									
IMD-NEC501RV	27 (687)	27-3/8 (705)	79-1/8 (2.010)	1	5	R290	0,24 (110)	36 °F / 46 °F (+2°C / +8°C)	1/3	15 (407)	3,7	300 (136)
IMD-NEC501FV	27 (687)	27-3/8 (705)	79-1/8 (2.010)	1	5	R290	0,24 (120)	36 °F / 46 °F (-15°C/-25°C)	3/4	15 (407)	4,88	300 (136)

PLAN VIEW

ELEVATION

RIGHT VIEW

PLANT VIEW

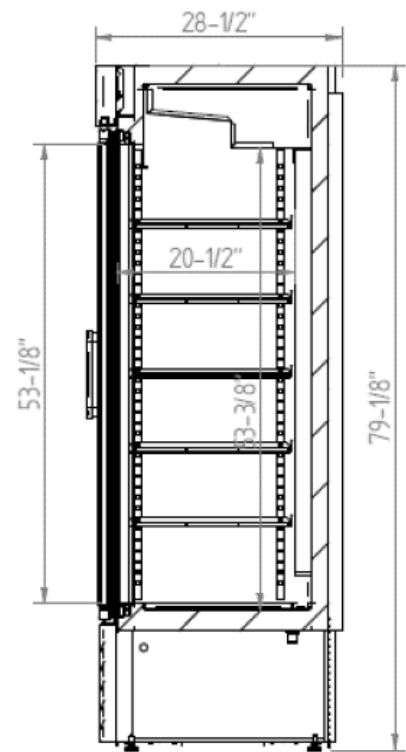
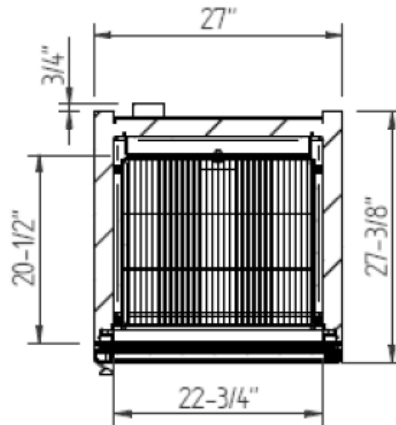
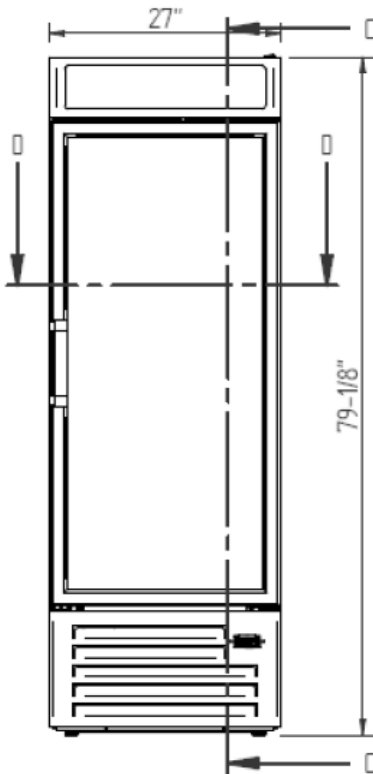

IMD-NEC501RV
 IMD-NEC501FV

Revision:02 Date: 14/04/2023 IMD-NEC501RV_FV

ETL LISTED TO UL471 STANDARD AND SANITATION CLASSIFIED TO NSF7 – WE RESERVE THE RIGHT TO CHANGE SPECIFICATIONS WITHOUT PRIOR NOTICE



INFIRICO-North America Corporate División
 1409NW 84th Avenue, Doral FL 33126
 (305) 777 9599 ext.700 / f (305) 777 9598
 Toll Free 855-340-4637

www.infrico.us
sales@infrico.com