



# Viper™ Low Overrun 3 Flavor Frozen Dispenser - Tall

Specification Guide

VIPER™ LOW OVERRUN



## Features

### High Capacity

Surge capacity dispensing 10 (16oz) consecutive drinks per barrel with a continuous draw capacity of 75-82 fl.oz per minute

### Patented Intelligent Defrost™

Manages product quality and bypasses unnecessary defrost times

### Defrost Lock-Out Times

Schedule defrost lockout times to avoid down time during peak demand periods

### Sleep Mode

Schedule sleep modes to conserve energy during off hours

### QR Code

Quickly access service manuals and easy-to-follow training videos

### C3 Technology

Cooling, carbonation, and controls provide unmatched drink profile consistency and minimizes syrup usage

### Serviceability

Reduced maintenance and service times with a 0.3% out of the box failure rate

### Programmable Flavor Barrels

Individual barrel flexibility and profile settings

### ADA Compliant

Stainless push handle valve



MARMON  
Foodservice  
Technologies

A BERKSHIRE HATHAWAY COMPANY



# Viper™ Low Overrun 3 Flavor Frozen Dispenser - Tall

Specification Guide

## Technical Specifications

<b>Electrical Requirements</b>	230V +/- 15V 60Hz, 30a, single phase <i>Includes 8ft. power NEMA L6-30P molded plug connection.</i>
<b>Pressure Requirements</b>	CO2 = 75 psig    Water = 25 min psig dynamic
<b>Draw Capacity</b>	75-82 oz/min continuous, alternating barrels @ 75° F (24°C)
<b>Refrigeration</b>	19,000 BTU, R448A
<b>Minimum Clearance Requirements</b>	Top: 12" (305mm)    Both Sides: 2" (51mm)    -or-    Back: 2" (51mm) <i>for temperatures &lt; 90°F (32°C)</i>
<b>Unit Dimensions</b>	22.75"W x 32.5"D x 43.7"H (577.85mm x 825.5mm x 19.8mm)
<b>Graphic Card Dimensions</b>	22.5"W x 18.75"H (571.5mm x 8.5mm)
<b>Flavor Card Dimensions</b>	6.5"W x 4"H (165.1mm x 101.6mm)
<b>Unit Weight</b>	465lbs (211kg)
<b>Shipping Weight</b>	Unit: 500lbs (227kg)    Cart: 200lbs (91kg)
<b>Agency Listing</b>	 

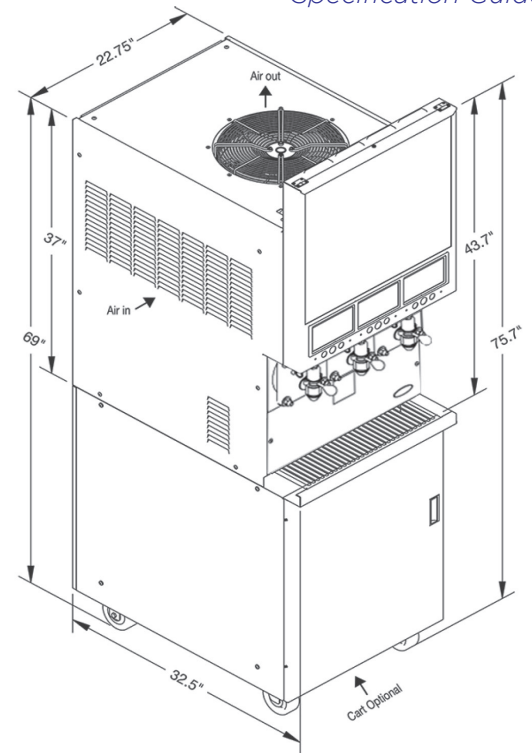

Model Number	Description
621366242LO	Viper Low Overrun 3 Barrel, 60Hz, R448A, Air Cooled, Full-travel Motorman Valves, Tall Merchandiser, N. American Power Cord
<i>Not all configurations are available - please contact a Cornelius® expert for additional information</i>	

Accessories Number	Description
629087406	Leg kit, 4" Height (order 4 per unit)
620053990	Viper 3 barrel cart, stainless steel
620046410	Viper 3 barrel generic graphic for tall merchandiser
620042868	Generic flavor card set (includes 18 flavors)
620051378	Coke flavor card set
620051379	Pepsi flavor card set
620067479	Pre-wired buck boost transformer
629096928	Viper 3 barrel installation kit
621058482	Viper 3 barrel pre-plumbed cart
326002000	Drain kit for drip tray
<i>Refer to Installation Manual for required installation materials - A Buck/Boost transformer is recommended for most installations</i>	

To learn more and see **Viper™** in action, visit [cornelius.com](http://cornelius.com)  
To contact a Cornelius® expert today, visit [cornelius.com/contact-us](http://cornelius.com/contact-us)