



COMPETITOR SERIES®

PROJECT: _____
 LOCATION: _____
 ITEM#: _____
 QUANTITY: _____



C-HCT14-S



C-HCT27-S



C-HCT36-S



C-HCT48-S

HEATED COUNTER-TOP DISPLAY CASES, STRAIGHT GLASS, FRONT & REAR SLIDING DOORS

- Beautiful ergonomic construction
- Dial temperature controller with mechanical temperature read-out
- All stainless steel interior & exterior front, glass covered black sides
- Glass front, sides and top
- Sliding glass doors in the front and rear to access the food products
- LED display light box with food railing on sides
- LED interior lighting
- Maintains temperatures between 86°F to 194°F
- Removable water pan to add humidity to interior
- Pre-installed feet
- Cantilever, gray epoxy-plated shelves
- Migali® Protection Plan: 2 Year Parts & Labor Warranty, 5 Year Compressor Warranty

MODEL	DOORS	SHELVES	CAPACITY CU/FT	AMPS	ENERGY CONSUMPTION KWH/24 HR	PLUG TYPE	TEMP RANGE	EXTERIOR DIMENSIONS W X D X H**	INTERIOR DIMENSIONS W X D X H	PACKAGED DIMENSIONS W X D X H**	WEIGHT	PACKAGED WEIGHT
C-HCT14-S	Sliding	3	2.6	5.4		Nema 5-15P	+86°F (~) +194°F	13.4 x 19 x 27.3	13 x 16.9 x 16.9	16.02 x 21.73 x 28.35	44	48.5 lbs.
C-HCT27-S	Sliding	3	3.3	9.5		Nema 5-15P	+86°F (~) +194°F	26.5 x 19 x 27.3	26.1 x 16.9 x 16.9	29.13 x 21.73 x 28.35	62.8	68.3 lbs.
C-HCT36-S	Sliding	3	4.8	12.6		Nema 5-15P	+86°F (~) +194°F	33.5 x 19 x 27.3	33.1 x 16.9 x 16.9	36.14 x 21.73 x 28.35	88.1	94.7 lbs.
C-HCT48-S	Sliding	3	6.5	12.6		Nema 5-15P	+86°F (~) +194°F	46.9 x 19 x 27.3	46.5 x 16.9 x 16.9	49.53 x 21.73 x 28.35	110.2	116.8 lbs.

NOTE: MIGALI® RESERVES THE RIGHT TO CHANGE SPECIFICATIONS WITHOUT NOTICE

FOR COMMERCIAL USE ONLY



TOLL FREE: 800.852.5292
 WEB: www.migali.com



DIMENSIONAL DRAWINGS

C-HCT14-S

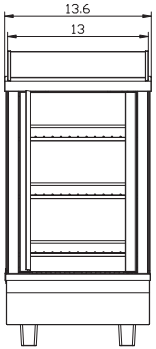

C-HCT27-S

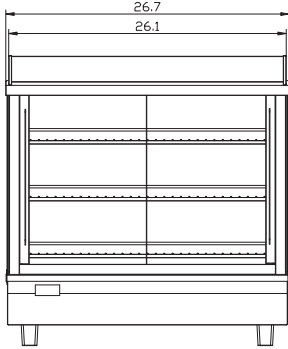

C-HCT36-S

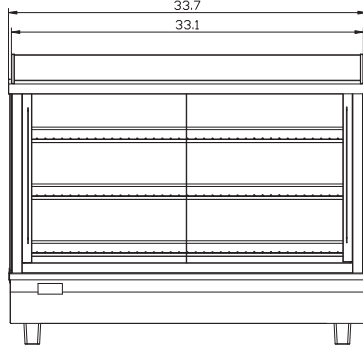

C-HCT48-S

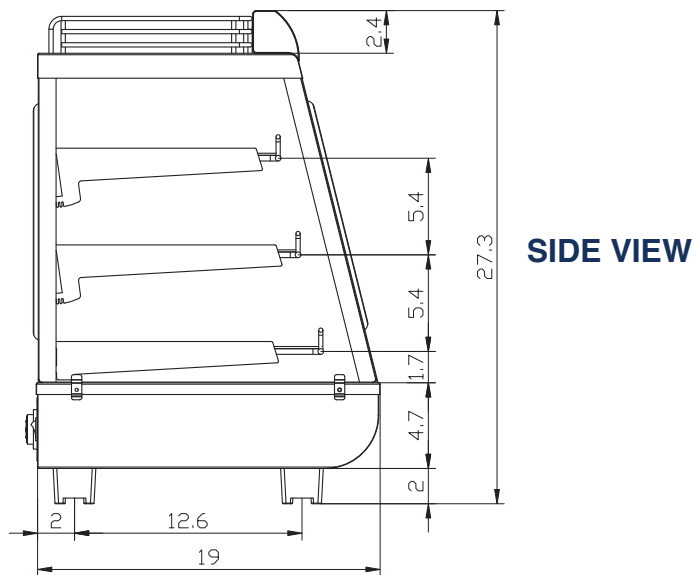
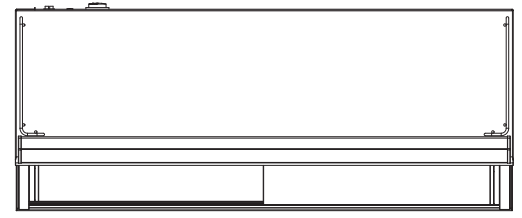
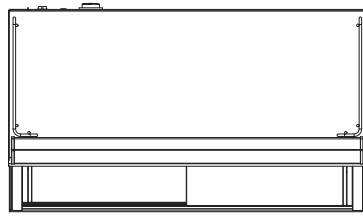
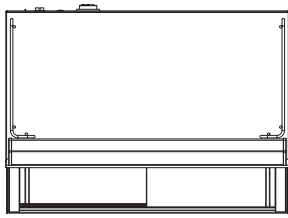
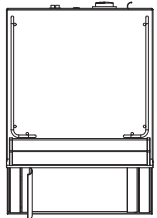
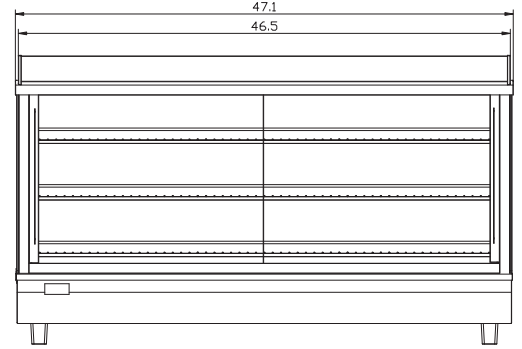

MIGALI® REMAINS AN AMERICAN FAMILY COMPANY SINCE 1955