

8 7 6 5 4 3 2 1

D
C
B
A

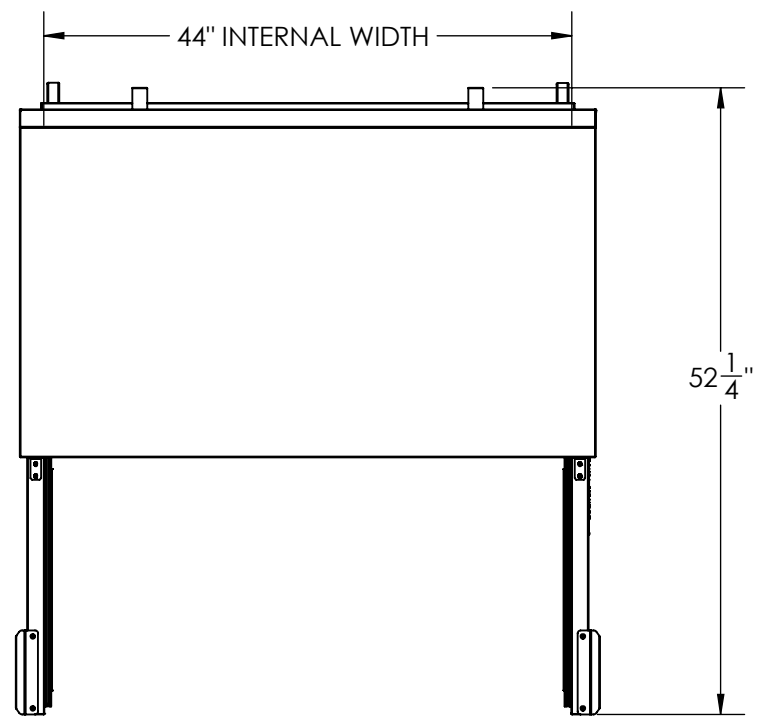
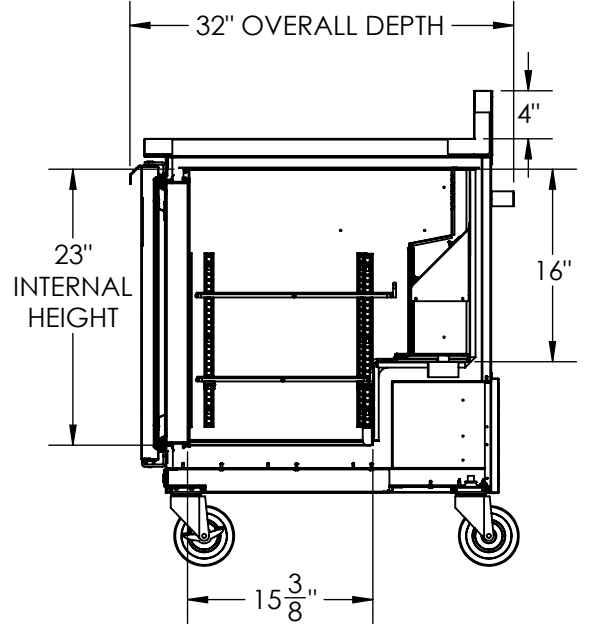
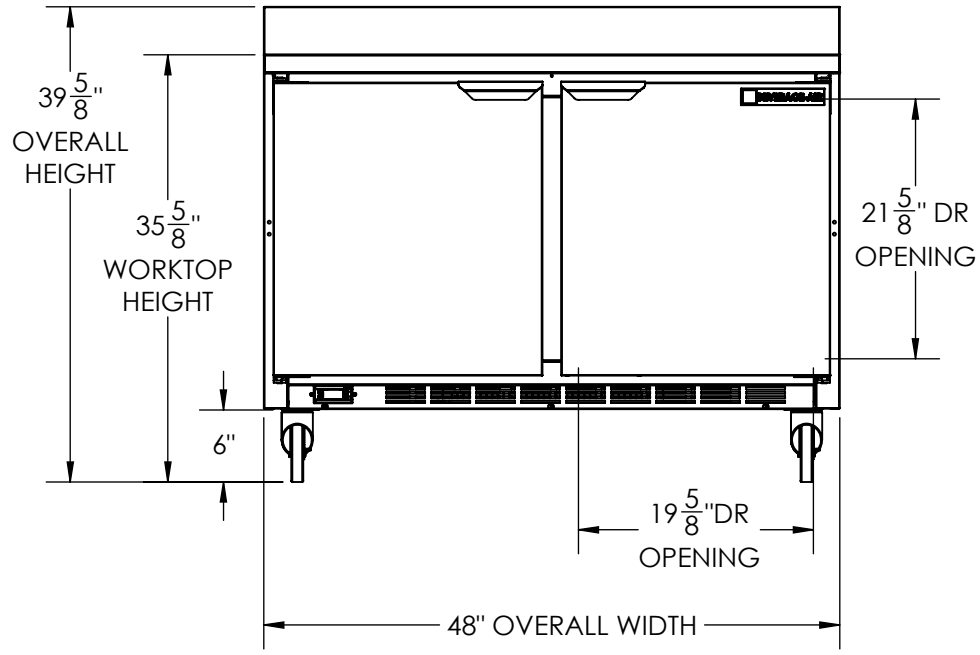

D
C
B
A

***** END OF REV *****

REV	REVISION RECORD	DATE	BY	CHK	ECN. NO.

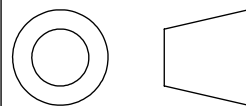
THIRD ANGLE PROJECTION	UNLESS OTHERWISE SPECIFIED:	NAME	DATE	 BEVERAGE-AIR BROOKVILLE, PA WINSTON-SALEM, NC beverage-air.com
	DIMENSIONS ARE IN INCHES TOLERANCES: ANGULAR: ± 2° ONE PLACE DECIMAL ± .060 TWO PLACE DECIMAL ± .030 THREE PLACE DECIMAL ± .010	DRAWN	AMK 08/18/16	
		CHECKED		
		ENG APPR.		
COMMENTS:	PROPRIETARY AND CONFIDENTIAL THE INFORMATION CONTAINED IN THIS DRAWING IS THE SOLE PROPERTY OF BEVERAGE-AIR CORPORATION. ANY REPRODUCTION IN PART OR AS A WHOLE WITHOUT THE WRITTEN PERMISSION OF BEVERAGE-AIR CORPORATION IS PROHIBITED.	Q.A.		TITLE:
		MODEL		SIZE B DWG. NO. WTR48AHC-FIP REV
		ENGINEERING REQUIREMENTS		SCALE: 1:16 WEIGHT: SHEET 1 OF 1
		SP100		

8 7 6 5 4 3 2 1