

SENOVEN®

YOUR EXPRESSWAY TO FLAVOR

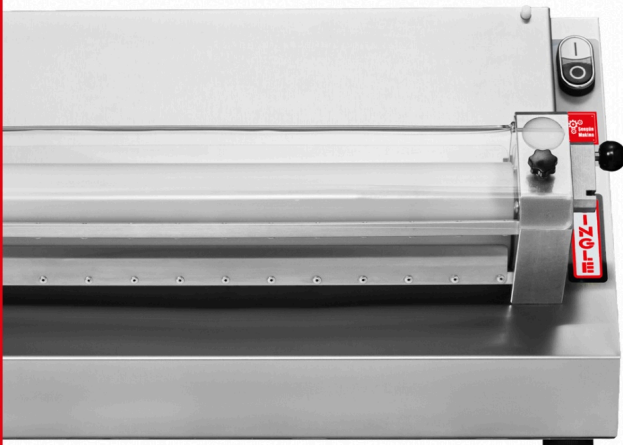

SM-30 SINGLE

SM-40 SINGLE

SM-50 SINGLE

SINGLE PASS DOUGH SHEETERS USER & MAINTENANCE MANUAL



Sengün
Makina

SECTION 1: WARRANTY CERTIFICATE**SECTION 2: INTRODUCTION****SECTION 3: MACHINE DESCRIPTION**

3.1 Dough Rolling Machine Description

3.2 Description of Body Components

3.3 Dough Rolling Machine Dimensions

3.4 Technical Specification Table

3.5 Electrical Connection Values

3.6 Protection Cover Assembly

3.7 Roller Cover Assembly

SECTION 4: USER INSTRUCTIONS

4.1 Adjustment of the Machine and Operating

4.2 User Instructions

SECTION 5: MAINTENANCE INSTRUCTIONS

5.1 Cleaning of the Body

5.2 Cleaning of the Scraper

SECTION 6: ELECTRICAL DIAGRAM

6.1 Dough Rolling Machines Electrical Diagram (for 230V)

6.2 Dough Rolling Machines Electrical Diagram (for 110V)

SECTION 7: LABELS

SECTION 1: WARRANTY CERTIFICATE

- Warranty terms start from the date of delivery to the customer and are valid for 1 year.
- SENOVEN LLC assures that the products are under warranty against manufacturing and assembly defects if they are assembled and used according to the instructions indicated in the user manual.
- Warranty terms are only valid for the machine that is sold within the certificate and if the information needed is unreadable, deleted, changed or scratched the warranty terms are no longer valid.
- During the warranty period, SENOVEN LLC assures that if a part is proven defective, related parts will be changed without cost.
- Proper installation according to the user manual, and usual maintenance such as lubrication, is the responsibility of the user and is not covered by this warranty.
- If any compelling reason happens the terms of the warranty certificate are not valid for the machine that is affected.
- During the warranty period, if the user makes any modification or repair without the allowance of the authorized person, the machine will be out of warranty.
- During the warranty period, if a problem or defect occurs regarding the warranty, the repairing time will be added to the warranty period. The time starts after the notification of the defect to the authorized person.
- This certificate is only valid for the United States and Canada region.

Dear User,

As Şengün Makina we have been producing the best products for more than 30 years with our experience. We proudly serve our products to over 80 countries. The best materials and international standards meet in the same production line for our customers.

To get the best experience with your machine, please read this manual very carefully, and please make sure you read all the warnings, cautions, and suggestions. With the proper setup and usage, we assure a reliable service for years. Thank you for choosing us.

SECTION 3: MACHINE DESCRIPTION

3.1 Dough Rolling Machine Description

The machine can be used in lahmacun, pizza, lavash and other dough rolling processes. Desired roller gap can be acquired via roller adjustment system. With this system, you can adjust the thickness and diameter of the dough. Thanks to its fast and easy-to-use feature, dough rolling can be done in a minimum of 3 seconds and a maximum of 5 seconds.

3.2 Description of Body Components

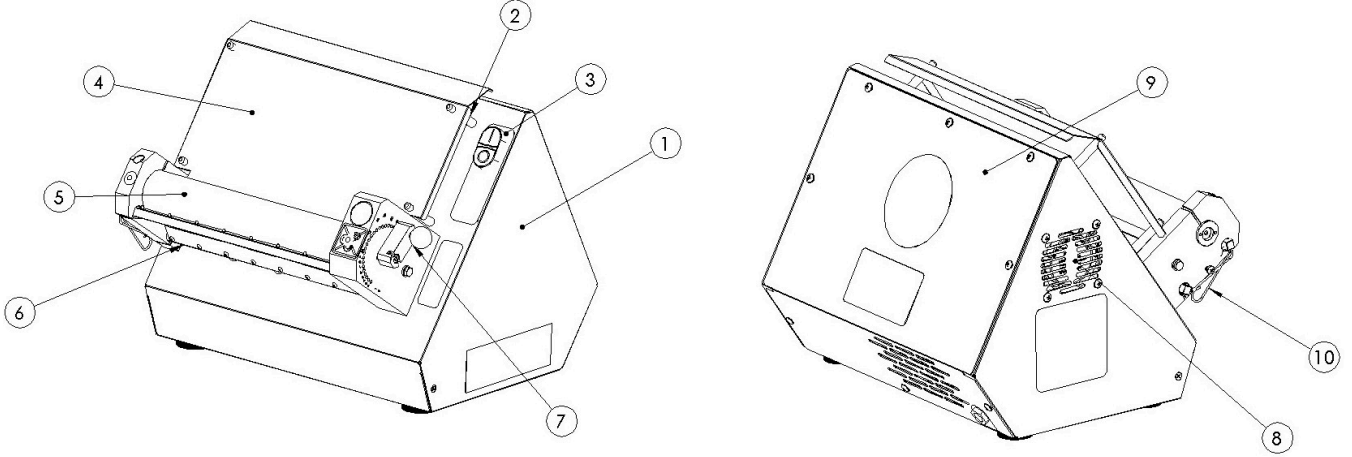

NO	SPARE PART DESCRIPTION
1	BODY
2	SHEET HOLDER PIN
3	BUTTON
4	FEEDER SHEET
5	TOP ROLLER GROUP
6	ROLLER SCRAPERS
7	ROLLER ADJUSTMENT LEVER
8	FAN
9	BACK COVER
10	SCRAPER WIRES

SECTION 3: MACHINE DESCRIPTION

3.3 Dough Rolling Machine Dimensions

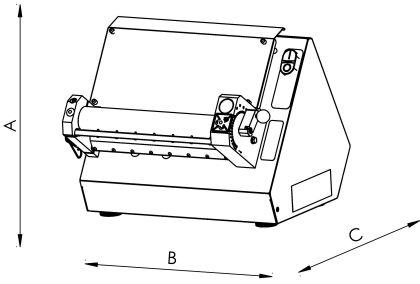

MODEL	A	B	C
SM-30 SINGLE	42 cm (16.53")	45 cm (17.71")	42 cm (16.53")
SM-40 SINGLE	42 cm (16.53")	56 cm (22.04")	42 cm (16.53")
SM-50 SINGLE	44 cm (17.32")	67 cm (26.37")	44 cm (17.32")

3.4 Technical Specifications Table

Technical Details	SM-30 SINGLE	SM-40 SINGLE	SM-50 SINGLE
Net Weight:	19 kg (41.8 lbs)	23.4 kg (51.48 lbs)	27.2 kg (59.84 lbs)
Gross Weight:	22.6 kg (49.72 lbs)	24.8 kg (54.56 lbs)	28.6 kg (62.92 lbs)
Dough Weight:	80 - 210 gr (0.17 - 0.46 lbs)	80 - 500 gr (0.17 - 1.1 lbs)	80 - 900 gr (0.17 - 1.98 lbs)
Average Dough Diameter:	19 - 29 cm (7.48" - 11.41")	26 - 40 cm (10.23" - 15.74")	33 - 50 cm (12.99" - 19.68")
Max. Roller Gap:	4.1 mm (0.16")	4.1 mm (0.16")	4.1 mm (0.16")
Production Capacity:	720 - 1200 Pieces	720 - 1200 Pieces	720 - 1200 Pieces

3.5 Electrical Connection Values

Electrical Requirements	Dough Rolling Machines (230V)	Dough Rolling Machines (110V)
Total Power:	0,22 kW	0,22 kW
Voltage:	220/230/240 VAC	110/120 VAC
Total Current:	1,9A	4A
Phase:	1 Phase	1 Phase
Hz:	50/60 Hz	60 Hz

3.6 Protection Cover Assembly

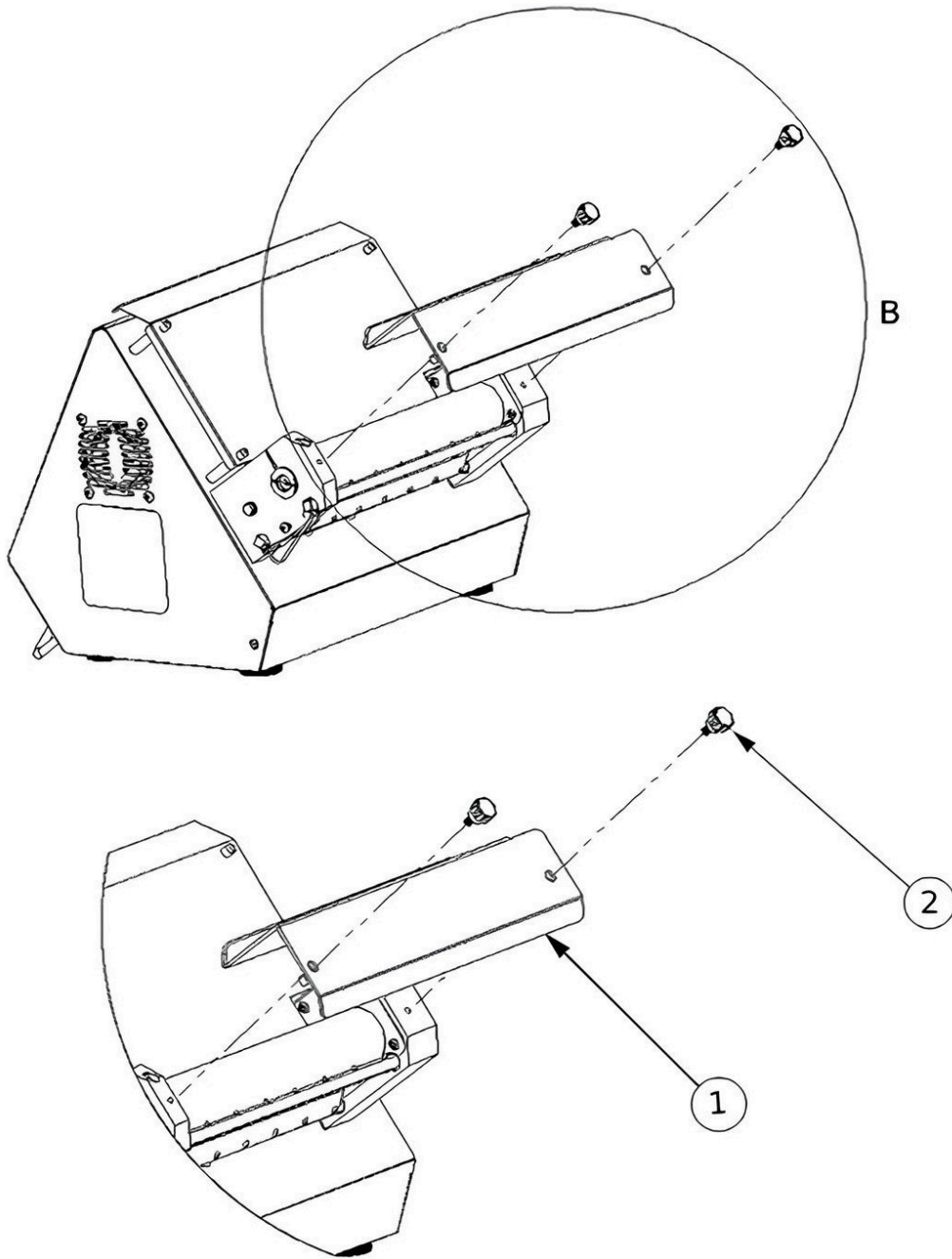

DETAIL B

NO	SPARE PART DESCRIPTION
1	ROLLER PRODUCTION COVER
2	BAKELITE

3.7 Roller Cover Assembly

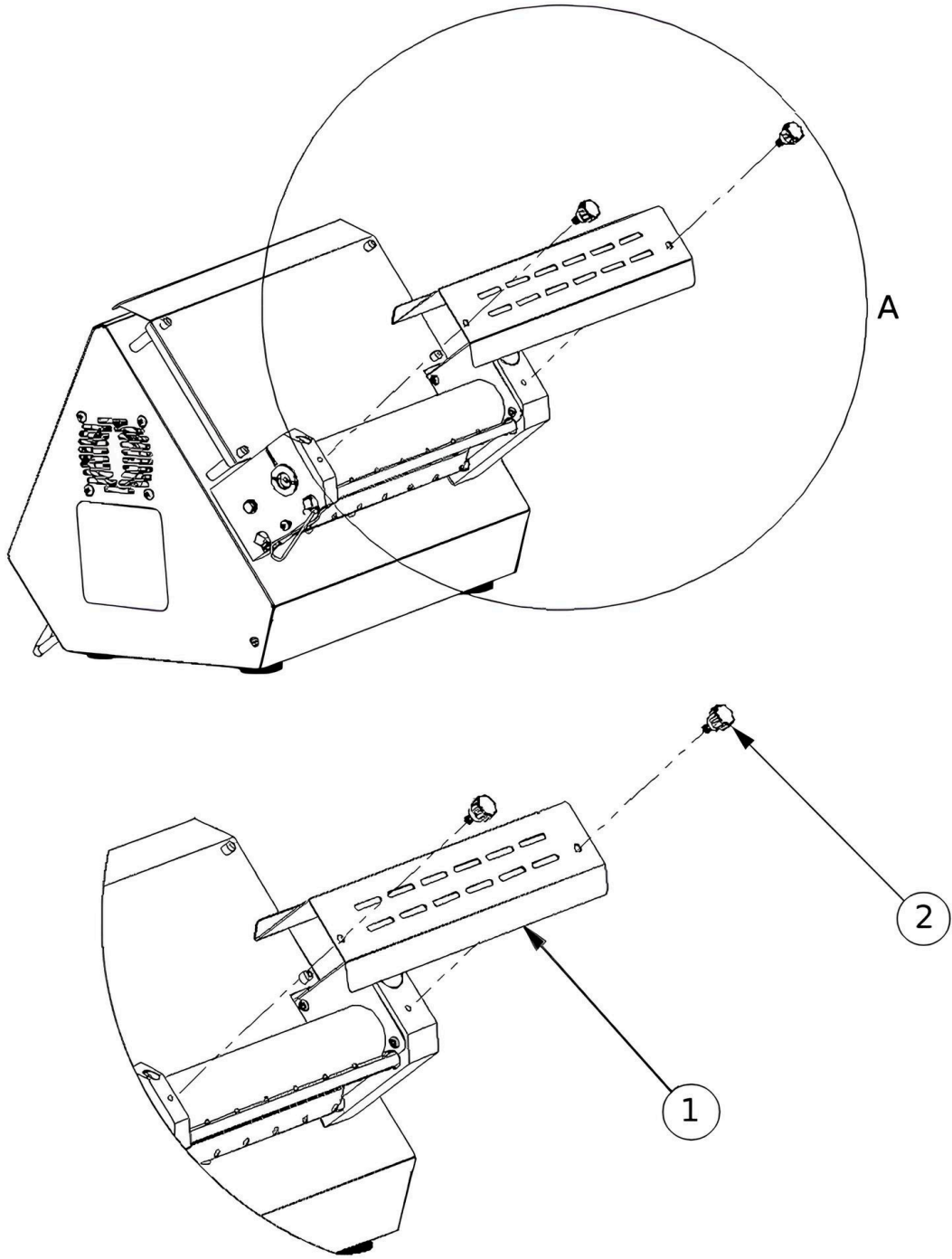

DETAILA

NO	YEDEK PARÇA TANIMI
1	ROLLER PROTECTION COVER
2	BAKELITE

4.1 Adjustment of the Machine and Operating

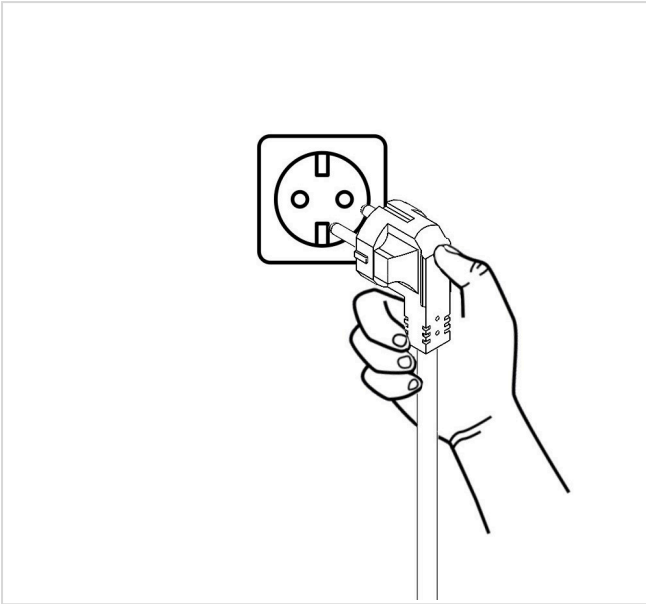

1. Plug the machine into a monophase outlet.

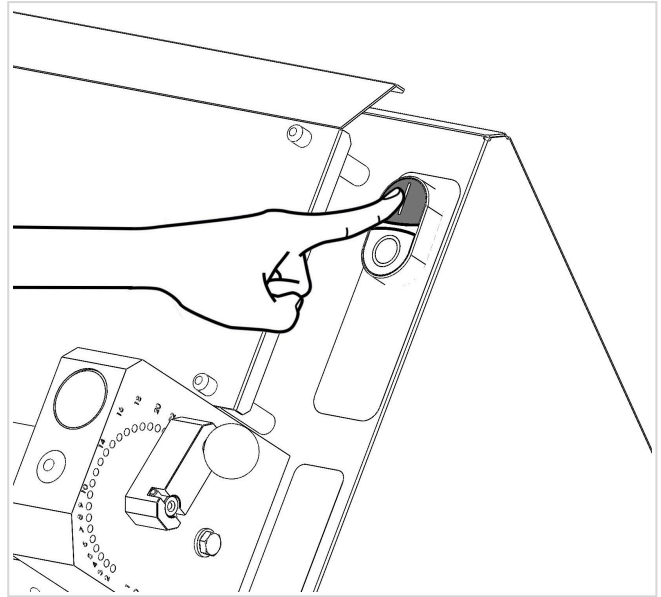

2. Press Button 1 to start the machine.

3. Adjust the roller gap as it shown in the picture. This will assign the thickness and diameter of the dough that you will roll.

To be able to adjust the roller gap, you can move the handle by pulling back and moving throughout the numbers. As the number increases, the thickness and roller gap escalate. As the number decreases, so does the gap, and the thickness reduces. After you achieve the desired gap, put the handle in its first place.

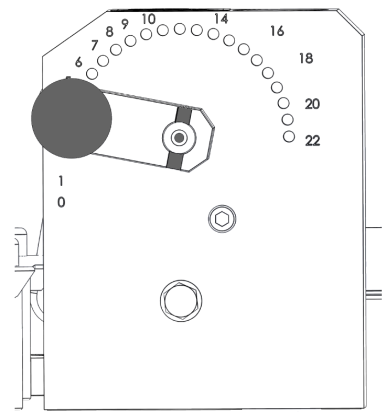

4.2 User Instructions

If you want to roll the dough circularly (lahmacun dough etc.);

- The dough must be made flat by pressing by hand.
- The dough must be passed through the roller gap.
- The dough that leaves the rollers must be passed through from the same place by flipping as shown in the picture.

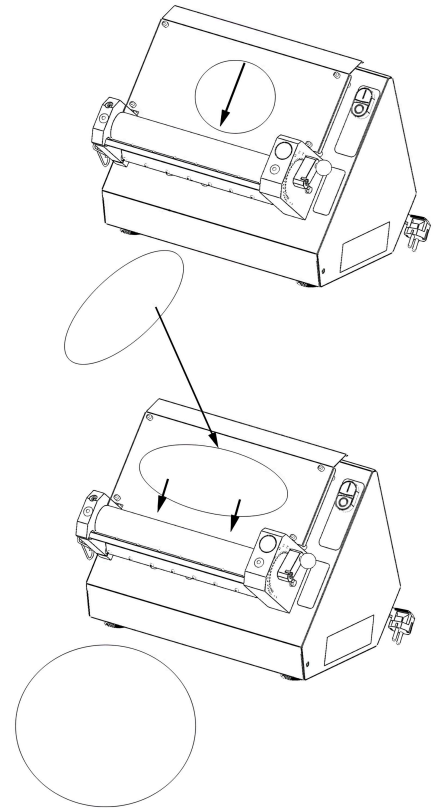

If you want to roll the dough elliptically (for pide dough);

- The dough must be made flat by pressing by hand.
- The dough must be passed through the roller gap.
- The dough that leaves the rollers must be passed through from the same place by rotating 45 degrees as shown in the picture.

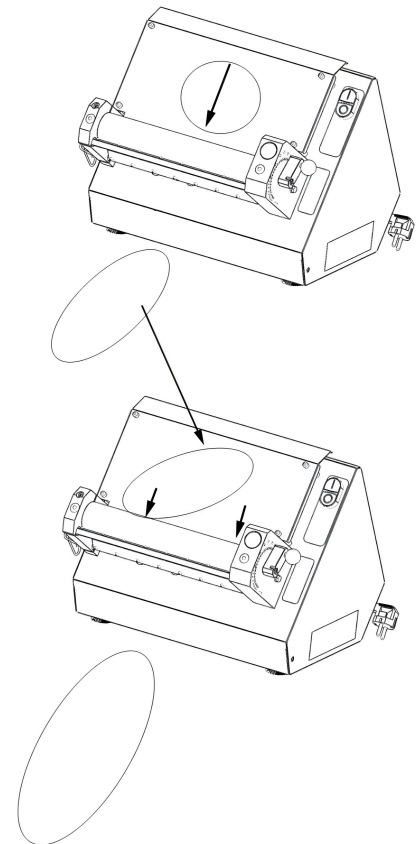

5.1 Cleaning of Body

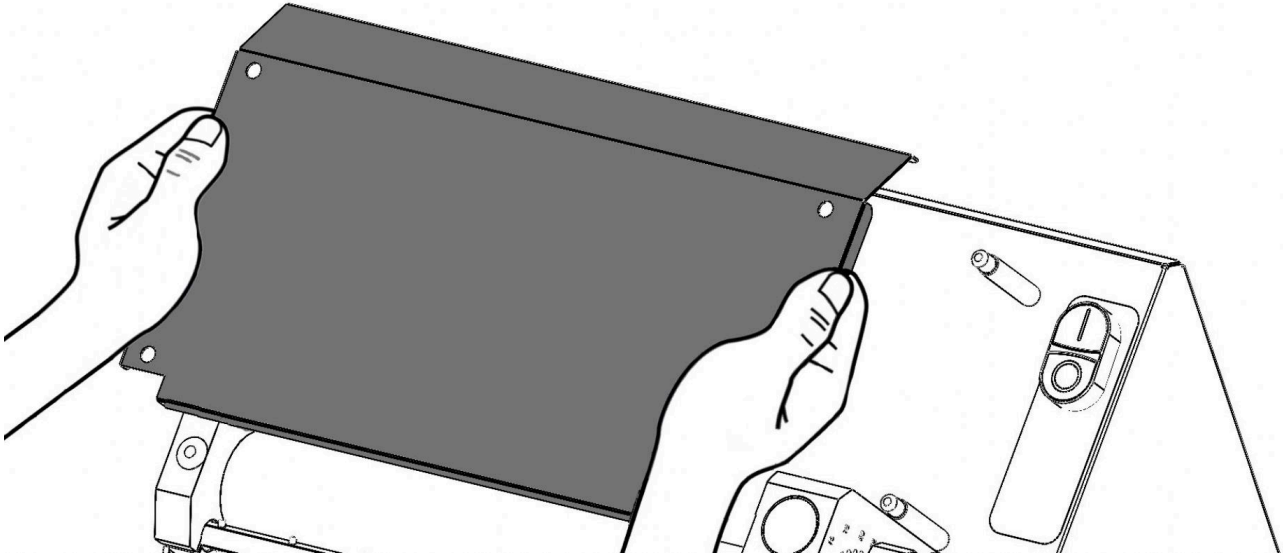

The first step to cleaning the body of the machine is disassembling the feeder sheets. After that, the flour and dough stains must be cleaned. While cleaning the machine, the machine must be unplugged and a wet cloth must be used. You have to wait until the machine dries before plugging it in again.

NOTE: The assembly is made by inserting the pins on the feeder sheet into their slots on the body. The pins must fit freely.

5.2 Scraper Cleaning

First thing you should do while cleaning the scraper, remove the spring as shown in the picture by pushing it upwards from the bolt. Then, the scraper is removed from its slot on the resting wedge as shown in the figure and the scraper sheet is cleaned. This procedure should be done every day.

NOTE: For the roller scrapers to work properly, the scraper springs must be taut.

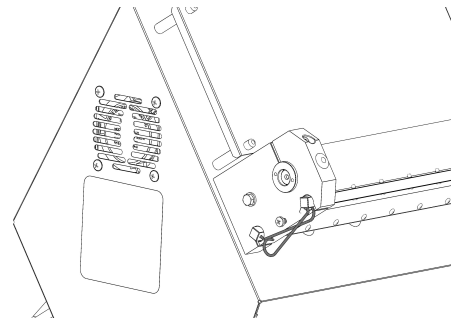

The machine has to be maintained after each use. Insufficient maintenance could affect the machine negatively. In case of faulty, authorized personnel must be informed immediately.

SECTION 6: ELECTRICAL DIAGRAM

6.1 Dough Rolling Machines Electrical Diagram (for 230V)

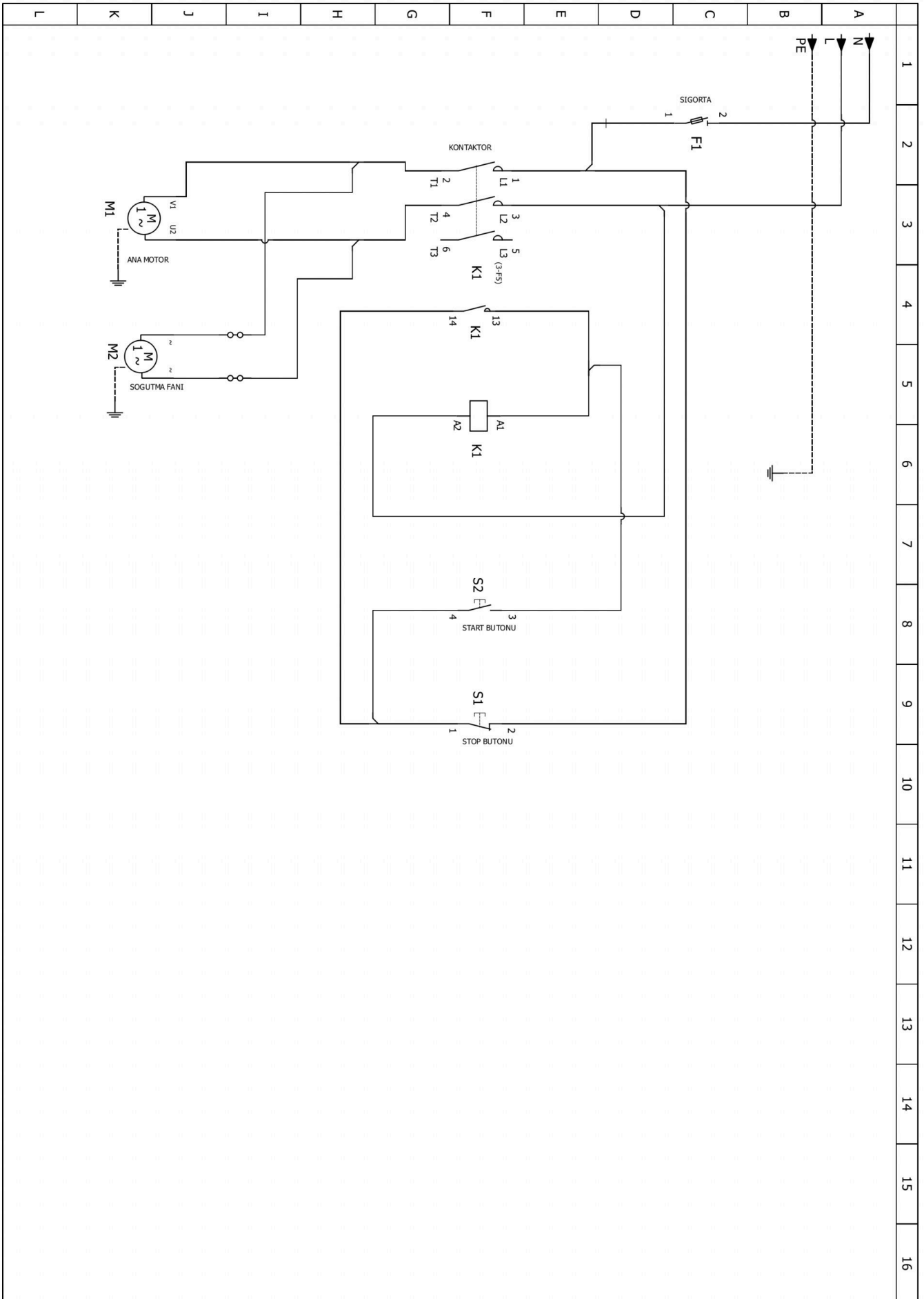

SECTION 6: ELECTRICAL DIAGRAM

6.2 Dough Rolling Machines Electrical Diagram (for 110V)

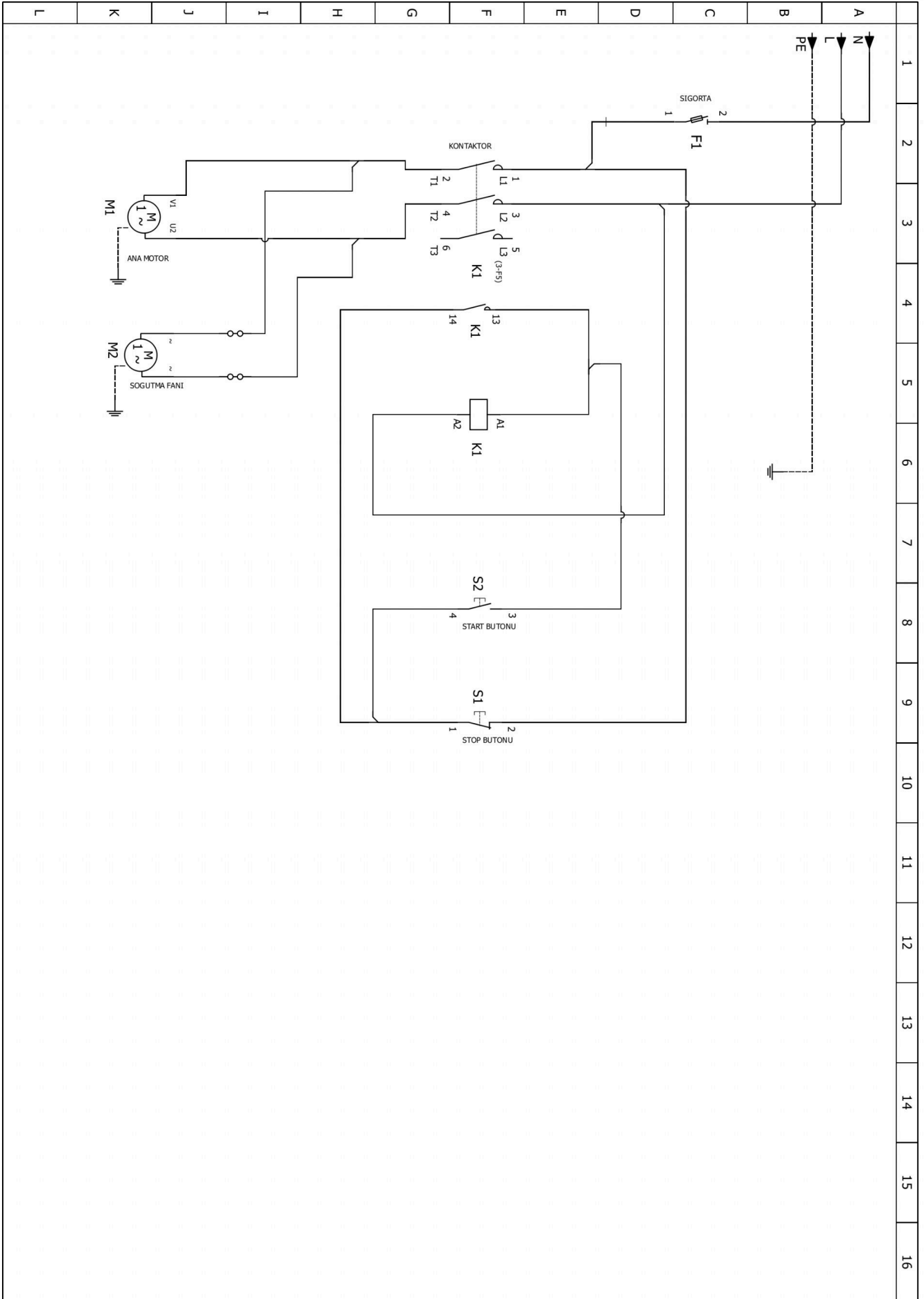

SECTION 7: LABELS

KULLANIM TAVSİYELERİ
USAGE RECOMMENDATIONS

Eğer Hamur Dairesel Olarak (Lahmacun, Pizza Hamuru vb.) Açılmak İsteniyorsa;

- Hamur yuvarlağı elle bastırılarak yatsı hale getirilir.
- Bu hamur merdane aralığından geçirilir.
- Merdaneden çıkan hamur yandaki şekilde görüldüğü gibi çevrilip tekrar merdane grubuna paralel olarak geçirilir.

For Rolling Circular Dough (Lahmacun Dough Etc.);

- Compress the dough and make it circular.
- Pass through the dough to the upper roller gap.
- Rotate the dough (shown in figure) then pass through the dough in parallel to the bottom roller gap.

Eğer Hamur Elips (Pide, Lavaş Hamuru vb.) Olarak Açılmak İsteniyorsa;

- Hamur yuvarlağı elle bastırılarak yatsı hale getirilir.
- Bu hamur merdane aralığından geçirilir.
- Merdaneden çıkan hamur yandaki şekilde görüldüğü gibi çevrilip merdane grubuna 45 derecelik açıyla geçirilir.

For Rolling Ellipse Dough (Pide Dough);

- Compress the dough and make it circular.
- Pass through the dough to the upper roller gap.
- Rotate the dough (shown in figure) then pass through the dough in 45° to the bottom roller gap.

ÖNEMLİ UYARI / WARNING!
MAKİNA ÇALIŞIRKEN TEMİZLİK YAPMAYINIZ.
DO NOT CLEAN THE MACHINE WHILE WORKING



ATTENTION!

- CUT ELECTRIC CURRENT BEFORE OPENING PROTECTION SYSTEM
- DO NOT CLEAR WHEN MACHINE IS WORKING

CAUTION ! CLEANING INSTRUCTIONS

- Do not put foreign materials between working machine rollers.
- Do not wash the machine with wet cloth and clean water, when electrical line is connected.
- Do not clean the machine, when it is working.
- Always check the cooling fan is running on the machine.
- Two monthly, open the back cover of the machine after removing the plug and clean inside of the machine by a pain brush or vaccum cleaner.
- At the end business, remove the roller scraper blades and clean by wet cloth or sponge. Do not hit hard objects and protect against bending.



SENOVEN®

YOUR EXPRESSWAY TO FLAVOR

USER & MAINTENANCE MANUAL

Istanbul - Türkiye

info@senoven.com | +90 212 671 23 23

SENOVEN LLC

Business Partner



New Jersey - USA

+1 (202) 306 44 63 | www.senoven.us