

**ASSISTANCE CENTRE  
AUTHORIZED RETAILER**

# **Softcooker S**

# **Softcooker S R**

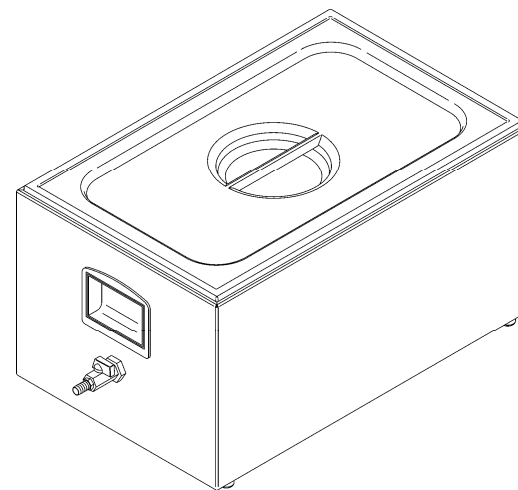

Softcookers S Ed. 03/2018



### 8.3 - WEEE Waste electrical and electronic equipment



**In conformity with article 13 of Legislative Decree no. 151 of 25 July 2005, "Implementation of the Directives 2002/95/EC, 2002/96/EC and 2003/108/EC concerning the reduction of the use of hazardous substances in electrical and electronic equipment, and the disposal of waste"**

*The symbol of the crossed out wheeled bin on the equipment or packaging indicates the product must be disposed of separately from other waste at the end of its useful life.*

*The segregated collection of this equipment at the end of its useful life is organized and arranged by the producer. The user wishing to dispose of the equipment concerned must therefore contact the producer and follow the manufacturer's instructions regarding the segregated collection of the equipment at the end of its useful life.*

*Suitable segregated collection of the equipment for subsequent recycling, treatment or environmentally friendly disposal helps prevent damage to the environment and to human health, and encourages the re-use and/or recycling of the materials that make up the equipment.*

*Abusive disposal of the product by the user shall result in the application of fines in accordance with the law in force.*

## FOREWORD

- *This manual was drawn up to provide the Customer with information concerning the machine and applicable standards, as well as instructions on operation and maintenance to ensure the optimal use and durability of the device.*
- **This manual is intended for operators authorized to use the machine and execute routine maintenance.**

## LIST OF CONTENTS

<b>PART 1 - ABOUT THE MACHINE</b>	4
1.1 - General precautions	
1.2 - The machine's safety devices	
1.3 - Description of the machine	
1.3.1 - Overview	
1.3.2 - Structural characteristics	
1.4 - Intended use	
1.5 - Unintended use	
1.6 - Master data	
1.7 - Protective and safety devices	
1.8 - Machine composition	
1.9 - Warning label	
<b>PART 2 - TECHNICAL DATA</b>	8
2.1 - Size, weight, properties...	
<b>PART 3 - RECEIPT OF THE MACHINE</b>	9
3.1 - Delivery of the machine	
3.2 - Checking the pack on receipt	
3.3 - Disposal of the packaging	
<b>PART 4 - INSTALLATION</b>	10
4.1 - Positioning of the machine	
4.2 - Connection to the mains	
4.3 - Wiring diagram	
<b>PART 5 - MACHINE USE</b>	11
5.1 - Controls	
<b>PART 6 - CLEANING THE MACHINE</b>	13
6.1 - General point	
6.2 - Maintenance	
<b>PART 7 - MAINTENANCE</b>	13
7.1 - General point	
7.2 - Power cable	
<b>PART 8 - DISMANTLING</b>	13
8.1 - Putting out of service	
8.2 - Disposal	
8.3 - WEEE Waste electrical and electronic equipment	

## PART 1 - ABOUT THE MACHINE

### 1.1 - GENERAL PRECAUTIONS

- The Softcooker S must only ever be used by a trained operator who has read and understood the safety instructions in this manual.
- In the case of shifts, make sure all the operators are suitably trained.
- Do not touch the heating elements with bare hands.
- **Always unplug the machine before cleaning or maintenance.**
- Always take the residual risks into account when servicing or cleaning the machine (and therefore when removing the protective devices).
- Always focus on the work in hand when executing maintenance or cleaning.
- Check the condition of the power cable on a regular basis; a worn or damaged cable can pose serious electrical risks.
- If there are any signs the machine is not working properly or you have reason to believe it is malfunctioning, you are advised to not use it and to contact the Assistance Centre immediately.
- Do not execute any repairs directly. Always contact an authorized repairman.

The user must never, for any reason, tamper with the machine. Always contact the Manufacturer in the event of a fault. Any attempt by the user or unauthorized operator to dismantle, change or tamper with a component of the machine shall forfeit the

**Declaration of Conformity** drawn up in accordance with EEC Directive 2006/42 and invalidate the warranty. The Manufacturer Firm cannot assume liability for damage due to tampering.

Moreover, the Manufacturer cannot be held liable for:

- Improper use or tampering with the machine by poorly trained operators;
- Poor or insufficient maintenance;
- Use of spare parts that are **not original** or type-approved;
- Failure to comply with some or all of the instructions in this manual;
- Treatment of the machine's surfaces with unsuitable products.

### Table of preset programs

Program	P01	P02	P03	P04	P05
Temperature	58°C	66°C	74°C	85°C	50°C
Time	40 min.	40 min.	4 h	6 h	10 min.

### 5.1 - Controls

## PART 6 – CLEANING THE MACHINE

**ATTENTION! Always unplug the machine before cleaning it to ensure it is no longer live. Pay attention to the temperature of the basin.**

### 6.1 - General point

- Clean the machine with a cloth soaked in a normal detergent at ambient temperature.
- Clean thoroughly all parts of the machine that come in contact with the product.
- Do not use high-pressure water jet machine or pressurized water spray.
- Do not use tools, brushes or other that could damage the surface of the machine.
- Do not put any of the components in the dishwasher.
- Make sure that no residual liquid infiltrates inside of the equipment, compromising its correct function and increasing possible risk of electrocution.

### 6.2 - Maintenance

To protect the tank, you are advised to add some vinegar in the tank with the water for each work cycle.

## PART 7 - MAINTENANCE

### 7.1 - General point

Always **unplug** the machine before servicing it **to ensure it is no longer live.**

### 7.2 - Power cable

Check the cable regularly to ensure it is in good condition. Call the ASSISTANCE CENTRE if the cable needs to be replaced.

## PART 8 - DISMANTLING

### 8.1 - Putting out of service

Should you decide to put the machine out of service, make sure it cannot be used by anyone: **unplug the machine and disconnect all the electrical connections.**

### 8.2 - Disposal

Once the machine has been put out of service, it can be eliminated in due course. To dispose of the machine correctly, contact a waste disposal firm taking into account the various materials that make up the various components.

## MENU

**MENU** button: press to set the work cycle.

- By pressing the MENU button once, the section where you can set the temperature will be displayed on screen. Use the UP and DOWN buttons to select the desired temperature.
- Press the MENU button to skip to time adjustment.
- The display will show the time in setting mode. Use the UP and DOWN buttons to select the desired cooking time.
- Press the START button to start the work cycle.

With the machine switched to STOP, by pressing the MENU button three times, you will directly access the preset programs. Use the MENU button to scroll the list of programs.



**ECO / PROG** button: Press this button to shift the work cycle to economy mode. When the mode is activated (the LED will go on), the work cycle will run at its lowest consumption range.

With the machine switched to STOP, hold this button down until "PROG 1" appears on the display. In this way, you will access the menu to modify the preset programs.

Use the UP and DOWN buttons to scroll the list of preset programs.

Use the MENU button to access the page where you can modify the selected program.

By pressing MENU once, the display will show the temperature in setting mode. Use the UP and DOWN buttons to select the desired temperature

The display will show the time in setting mode.

Use the UP and DOWN buttons to select the desired cooking time. Any changes made of the settings will be automatically saved.

Once the Softcooker S reaches the selected temperature, independently of whether you have or have not set the time and at the end of the work cycle, it will emit a SOUND SIGNAL.

When the work cycle has ended, press the STOP button to turn off the machine.

Unplug the machine.

Empty the tank.

**ATTENTION!** Water drainage must be done when the water temperature is equal to or less than 60°C.

The Softcooker S gives an error message when:

- The level of water in the container is too low ( ERR ), in which case the machine will also emit a SOUND SIGNAL.- The electronic components in the machine start to overheat ( ERR ),
- The temperature probes do not detect the same temperature as one of the two probes is faulty ( ERR ).

## 1.2 - THE MACHINE'S SAFETY DEVICES

The electrical and mechanical safety devices conform to directives **2006/95** and **2006/42**, and standard **60335-1**.

The Softcooker protects against electrical and mechanical risks during operation as well as cleaning and maintenance.

There are however some **RESIDUAL RISKS** that cannot be fully eliminated. These are headed **ATTENTION** and concern the risk of burns, bruises or electrocution when loading and unloading the product and cleaning the machine or due to improper use of the product.

## 1.3 - DESCRIPTION OF THE MACHINE

### 1.3.1 - Overview

Our firm designed and constructed the Softcooker S to guarantee the following:

- the sturdiness and stability of all the components;
- easy handling, with handles so they can be carried with convenience;
- high precision heating control;
- an operating temperature of between 30 and 100°, at a precision of +/- 0.3° C.

### 1.3.2 - Structural characteristics

The Softcooker S was made entirely of AISI 304 stainless steel to ensure hygiene and resistance to acids and salts, as well as excellent resistance to oxidation.

- The heating element is on the bottom of the basin which heats up and then transmits that heat to the water inside of it.
- Emergency block in case an abnormal temperature is detected.

### 1.4 – Intended use

The Softcooker S is intended for vacuum cooking in a water-filled immersion tank.

**The machine was not designed to directly cook foods or for any use other than heating foods.**

### 1.5 – Unintended use

The machine must be put to the sole use intended by the manufacturer; in particular:

- **Do not** use the machine unless it has been installed correctly and all the protective devices are in good condition and properly fitted, in order to prevent the risk of serious harm to yourself.
- **Do not** touch the electrical components without having first unplugged the machine: **risk of electrocution.**
- **Do not** start up the machine when this is not working properly.
- Before using the machine, make sure the machine is perfectly safe and that any dangerous conditions have been eliminated in an appropriate manner. If

there are any irregularities, stop the machine and request the assistance of a maintenance technician.

- **Do not** allow unauthorized operators to use the machine.

Emergency action in the event of electrical accidents first of all, remove the victim from the conductor (as he is likely to be unconscious). This operation is dangerous.

The victim in this case is a conductor: touching him is to risk electrocution.

It is advisable therefore to disconnect the contacts directly from the line supply valve, or if this is not possible, move the victim away using insulation materials (pieces of wood or PVC, cloth, leather, etc.).

The victim should be given immediate medical attention and taken to a hospital.

### 1.6 – Master data

Please state the machine's exact "**Model**", "**Serial number**" and "**Year of manufacture**" when contacting our assistance service. This will help us give you a quick and efficient response.

We will ask you to state the machine model and serial number whenever you contact us, so make sure to check this on the data plate, pictured in Fig. n°1.

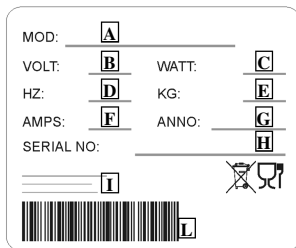

Fig. n°1

- A = machine model
- B = power supply
- C = engine power
- D = engine frequency (Hz)
- E = weight
- F = amperage
- G = year of manufacture
- H = serial number
- I = manufacturer
- L = barcode

### 1.7 – Protective and safety devices

#### ATTENTION!

Before using the machine, double check that it is positioned correctly and that it is in integral condition.

Before each work shift, check the integrity of the machine. If it is not, immediately notify the Head of Maintenance.

**ATTENTION! There is no device to display the water level:** always use the machine with a level of water that is 4-5 centimeters from the upper rim. Using the machine without sufficient water in the basin will compromise the correct function and the quality of the cooking. If used empty, the basin will overheat, creating serious risk of burns and will damage the machine.

## PART 5 - MACHINE USE

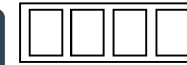
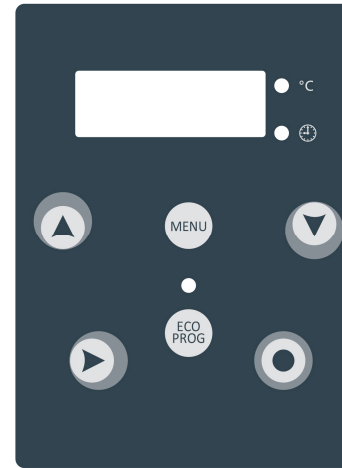

#### Display:

a four-digit display that gives the temperature and time, with alternate every 5 seconds, and a description of the various pre-configured programs.



**START** button: press to start the work cycle.



**OFF** button: press to stop the work cycle.



°C

**Temperature Led:** this is at the side of the display and lights up when the work temperature is shown on the display during the work cycle.



**Timer Led :** this is at the side of the display and lights up when the work time is shown on the display during the work cycle.

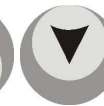

**UP and DOWN** buttons (+/-): use these to configure the temperature and time. Press the start button to start the work cycle.

With the machine switched to STOP, by pressing UP, you will directly access the preset programs. Use the UP and DOWN buttons to scroll the list of programs.

With the machine switched on, by pressing the UP and DOWN buttons you can modify the set temperature and time.

### 3.3 - Disposal of the packaging

All the packaging (cardboard, plastic support and polyurethane foam) is classified as solid urban waste; it can be disposed of without difficulty.

If the machine is installed in a country where there are specific regulations, you should dispose of the packaging in accordance with those regulations in force.

## PART 4 - INSTALLATION

### 4.1 - Positioning of the machine

Place the machine on a solid surface approximately 80 cm from the floor. The surface must be smooth, not slippery and resistant to high temperatures. Keep a minimum distance of 10 cm from walls or other objects, even if they are heat resistant.

**ATTENTION!** Machines equipped with taps must be connected to a sufficiently long pipe, in order to be able to move the machine and clean the worktop.

### 4.2 - Connection to the mains

A 3x1.5 mm<sup>2</sup> power cable 2.5 m in length and NEMA 5-15P plug is provided with the appliance. Connect the machine to a 120 Volt 60 Hz power supply. Check that the grounding system works perfectly and that the connection has a 0.03A differential magnetothermal switch.

Check the data on the technical – serial number plate is the same as that stated in the delivery and accompanying documents. Make sure also that the switch and socket are easy to access when the appliance is in use.

### 4.3 - Wiring diagram

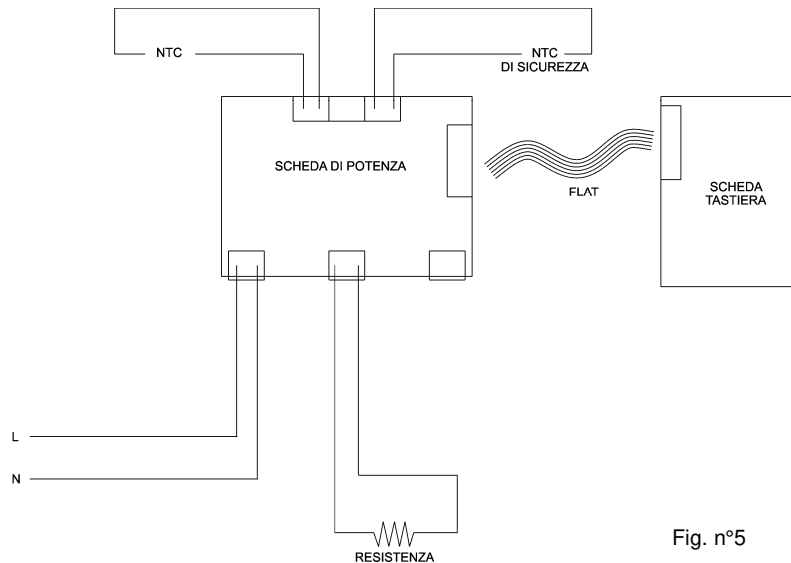

Fig. n°5

**Disabling device:** the machine stops and an error (HIGH) message appears on the screen when there is a fault with one of the probes and their temperature readings are different.

### 1.8 - Machine composition

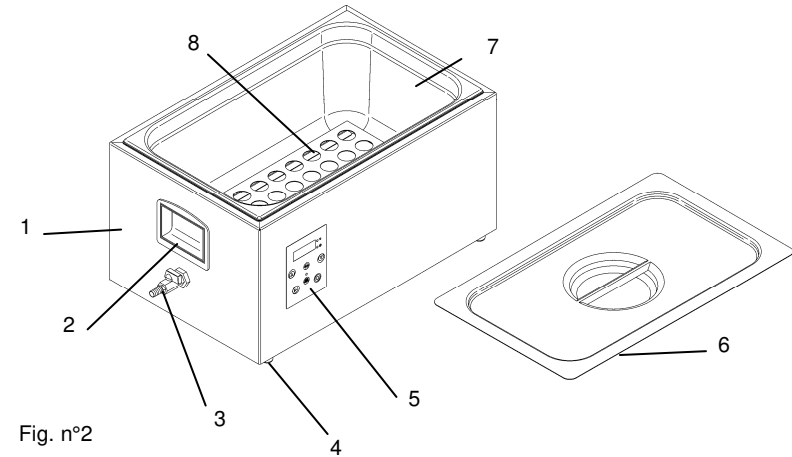

Fig. n°2

### LEGEND

1	Body	5	Controls
2	Handle	6	Lid
3	Tap	7	Basin
4	Feet	8	Bag protection

### 1.9 - Warning label

The warning label to side is applicate on the appliance. Label is intended to alert the user to the presence of uninsulated “dangerous voltage” within the product’s enclosure that may be of sufficient magnitude to constitute a rick of fire or electric shock to persons.

**ATTENZIONE**  
Scollegare la spina prima di rimuovere la copertura.

**WARNING**  
Isolate from mains before removing cover.

**ATTENTION**  
Avant d'enlever la protection s'assurer d'isoler l'appareil de l'alimentation.

**VORSICHT**  
Vor dem öffnen des Gerätes vom Netz trennen!

**ВНИМАНИЕ**  
Отключите от электрического питания перед снятием крышки.

## PART 2 - TECHNICAL DATA

### 2.1 - Size, weight, properties...

Fig.n°3 - Dimensions and max size of the machine

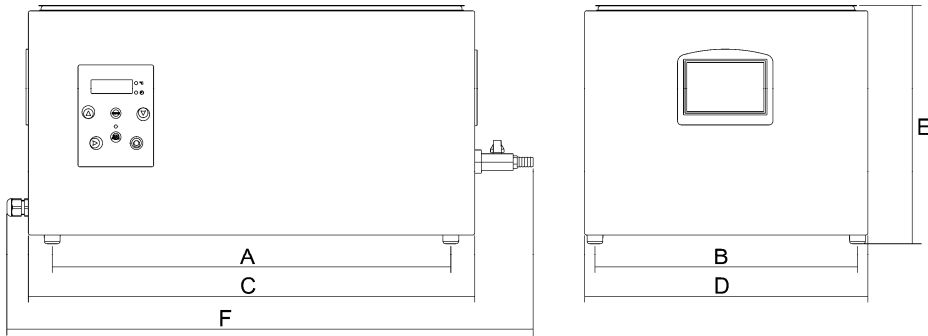

Model	Measure	Softcooker S or S R 2/3 GN	Softcooker S or S R 1/1 GN
<b>Power</b>	watt	1020	1700
<b>Power supply</b>		120V / 60Hz	120V / 60Hz
<b>Temperature</b>	°C	40 ÷ 115	40 ÷ 115
<b>Basin</b>	mm	2/3 Gastronorm	1/1 Gastronorm
<b>A x B</b>	mm	330x330	500x330
<b>C x D x E</b>	mm	390x360x300	560x360x300
<b>F</b>	mm	500	670
<b>Net weight</b>	kg	11	15



## ATTENTION

THE ELECTRICAL PROPERTIES OF THE MACHINE ARE STATED ON A PLATE ON ITS BACK; BEFORE CONNECTING THE MACHINE, REFER TO THE SECTION:

“ **CONNECTION TO THE MAINS.** ”

## PART 3 - RECEIPT OF THE MACHINE

### 3.1 - Delivery of the machine (refer to Fig.n°4)

The machinery is carefully packed before it leaves our warehouses.

The pack contains:

- A sturdy cardboard box with inside padding;
- The machine;
- This manual.

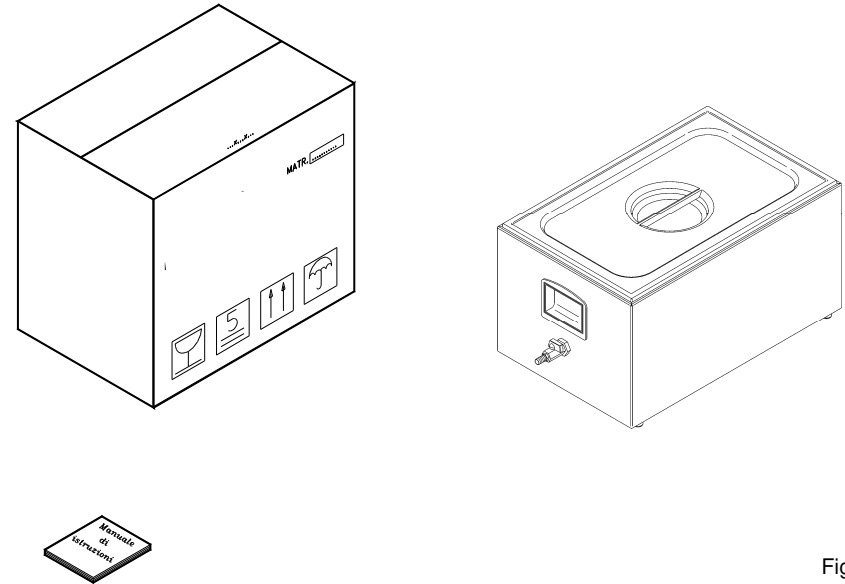

Fig. n°4

### 3.2 - Checking the pack upon receipt

When you receive the pack containing the machine, check the packaging carefully for any signs of damage it may have sustained during transport.

If the outer packaging looks as if it has been treated roughly, knocked or dropped, within three days of the date of delivery, as stated in the documents, and write a precise report on any damage the machine has sustained.