

CHAP. 8 - DISMANTLING

8.1 - OUT OF SERVICE

If for some reason it is decided to put the machine out of service, make sure that it cannot be used by anyone: **detach or cut the electrical connections.**

8.2 - DISPOSAL

Once the machine is put out of service it can be easily disposed of. To correctly dispose of the slicer, ask any company assigned to such a service carefully observing the materials used for the various components (**see chap. 4 par. 4.1**).

PALLADIO
300-330-350

Edition: 03/2008

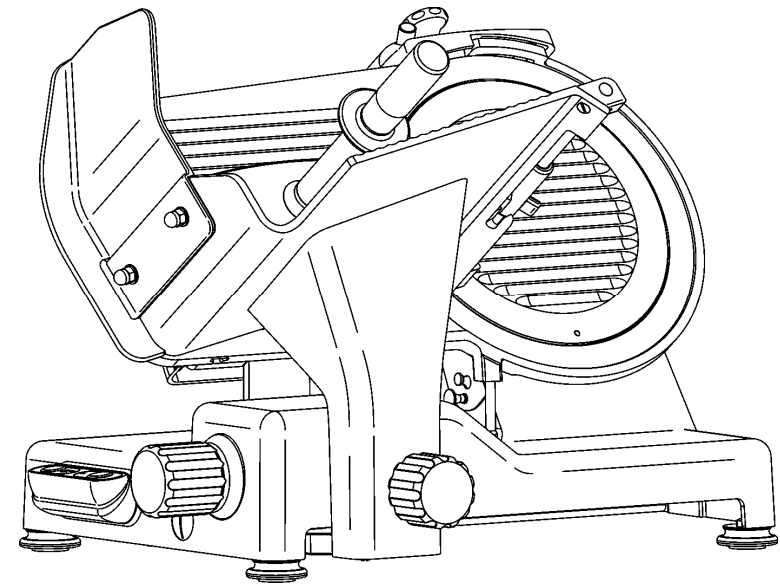

**SERVICE CENTRE
AUTHORISED DEALER**

Operating and Maintenance Manual

INTRODUCTION

- This manual has been re-presented to provide the **Client with all the information** on the machine and its safety regulations, and also the use and maintenance instructions which permit using the machine in the best way and maintaining its efficiency throughout time.
- This manual must be kept in its entirety until the machine is disposed of.
- This manual should be given to personnel in charge of the use and periodic maintenance of the machine.

INDEX OF CHAPTERS

CHAP. 1 - RECEIVING THE MACHINE page 5

- 1.1 - PACKAGE
- 1.2 - CHECKING THE PACKAGE UPON DELIVERY

CHAP. 2 - INSTALLATION page 7

- 2.1 - UNPACKING
- 2.2 - POSITIONING
- 2.3 - ELECTRICAL CONNECTION
- 2.3.1 - Slicer with single-phase motor
- 2.4 - 115 V. ELECTRICAL DIAGRAM - 'SIDNEY' PUSH-BUTTON PANEL
- 2.4.1 - 115 V. tension selection
- 2.5 - PRELIMINARY CHECK

CHAP. 3 - INFORMATION ON THE MACHINE page 12

- 3.1 - GENERAL PRECAUTIONS

CHAP. 4 - CONSTRUCTION FEATURES

- 4.2 - SAFETY DEVICES INSTALLED ON THE MACHINE page 14
- 4.2.1 - Mechanical safety
- 4.2.2 - Electrical safety
- 4.3 - DESCRIPTION OF THE MACHINE
- 4.4 - OVERALL DIMENSIONS, WEIGHT, FEATURES....

CHAP. 5 - MACHINE USE page 19

- 5.1 - OPERATIONAL CHECK
- 5.2 - LOADING AND CUTTING THE PRODUCT
- 5.3 - SHARPENING THE BLADE

CHAP. 6 - ROUTINE CLEANING page 22

- 6.1 - GENERALITIES
- 6.2 - CLEANING THE MACHINE

CHAP. 7 - MAINTENANCE

7.1 - GENERALITIES

Before carrying out any maintenance operations it is necessary to:

- a) disconnect the feed plug from the electrical network to completely isolate machine from the rest of the system.
- b) bring the graduated handgrip which regulates the thickness gauge to "0".

7.2 - BELT

The belt does not need to be regulated. Generally after 3/4 years it must be replaced, in this case call the "SERVICE CENTER".

7.3 - FEET

The feet could deteriorate in time and lose their elasticity, therefore decreasing the stability of the machine. Replace them by calling the "SERVICE CENTER".

7.4 - FEEDING CABLE

Periodically check the state of wear and tear of the cable and call the "SERVICE CENTER" for its replacement.

7.5 - BLADE

Check that the diameter of the blade, after many sharpenings, has not been reduced more than 10 mm. compared to the original diameter. For its replacement call the "SERVICE CENTER".

7.6 - GRINDERS

Check that the grinders continue to have their abrasive property during the sharpening. When they are no longer abrasive they must be replaced as to not damage the blade, therefore call the "SERVICE CENTER".

7.7 - SLIDING GUIDES LUBRICATION

Occasionally put a few drops of oil (from the tube that is provided) on the round bar that the trolley slides back and forth on, through the hole (OIL) located on the side of the graduated handgrip.

7.8 - PUSH-BUTTON PANEL LABEL

The push-button panel label can be marked and/or punctured with time. In such a case call the "SERVICE CENTER" to replace it.

6.2.3 - Cleaning the sliceguard (Fig. n°50)

To remove the sliceguard simply grasp the handgrip (1) and pull up so that the two pins unhook (2), and then extract the sliceguard.

At this point clean the sliceguard with warm water, the equipped detergent or with neutral detergent (pH 7).

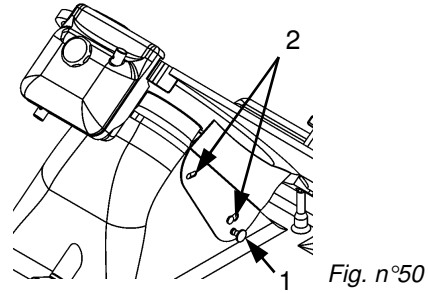

Fig. n°50

6.2.4 - Cleaning the sharpener

To clean the sharpener it is necessary to adhere to the following instructions:

1. lift (a) the sharpener up to the top;
2. loosen the knob (1);
3. lift (b) the cup (2) and extract it so that the knob (1) passes through the larger opening in the cup (2);
4. rub the grinders with a brush, while cleaning the other components with warm water, the equipped detergent or with neutral detergent (pH 7).

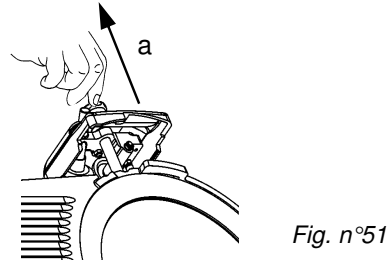

Fig. n°51

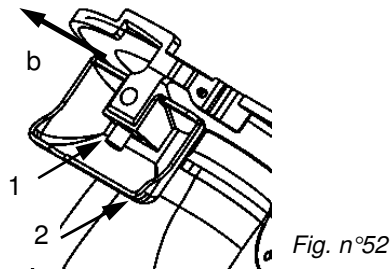

Fig. n°52

6.3 - SLIDE GUIDES LUBRICATION

The slide guides on the carriage (1-2) must be lubricated periodically with the equipped oil (a).

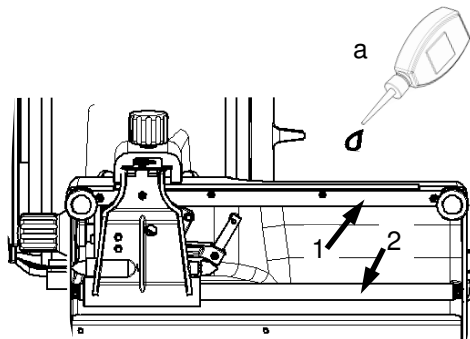

Fig. n°53

CHAP. 7 - MAINTENANCE

- 7.1 - GENERALITIES
- 7.2 - BELT
- 7.3 - FEET
- 7.4 - FEEDING CABLE
- 7.5 - BLADE
- 7.6 - GRINDERS
- 7.7 - SLIDE GUIDES LUBRICATION
- 7.8 - PUSH-BUTTON PANEL LABEL

page 25

CHAP. 8 - DISMANTLING

- 8.1 - PUTTING OUT OF SERVICE
- 8.2 - DISPOSAL

page 26

CHAP. 1 - RECEIVING THE MACHINE

1.1 - PACKAGE

The slicer is shipped in a package which consists of (Fig. n°1): cardboard box, wooden pallets and protective nylon. They should be disposed of separately and according to the norms in force in the country of installation.

	Dimensions AxBxC	Gross weight (Kg)
PL 300	600x760x690	-
PL 330	600x760x690	-
PL 350	600x760x690	-

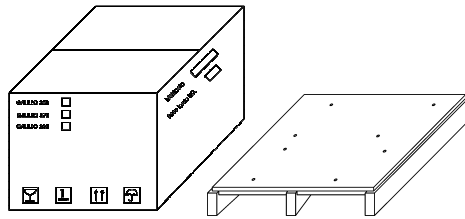

Fig. n°1



WARNING!

Do not place more than one of the same package on top (Fig. n°3).

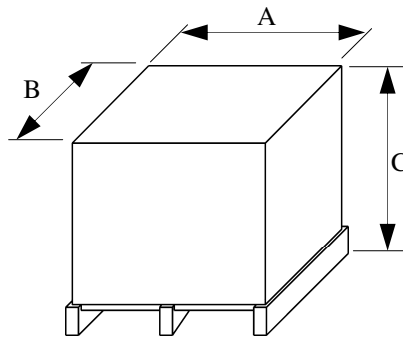

Fig. n°2

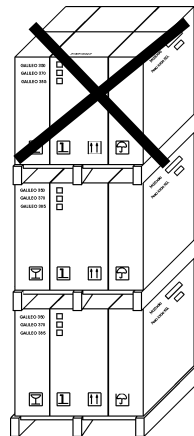

Fig. n°3

with warm water, the equipped detergent or neutral detergent (pH 7)
Fig. n°46.



Fig. n°46

6.2.2 - Cleaning the blade, the bladeguard and the ring

WARNING: a pair of metallic gloves must be worn while cleaning the blade (1) (Fig. n°48) and a damp cloth must be used.

Unscrew the handgrip from the bladeguard tie rod (1) and extract the bladeguard (2) using the proper grip to hold it (Fig. n°47). At this point it is possible to clean the blade a Fig. n°48.

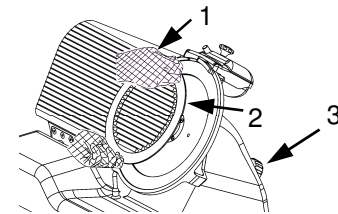

Fig. n°47

To clean the surfaces opposite the blade and the ring, the blade must be extracted in the following way:

- 1.unhook the bladeguard (Fig. n°47);
- 2.take out the sharpening device (Fig. n°49 ref.a) and open, by using the graduated handgrip, the thickness gauge enough to make the jig (Fig. n°49 ref.b) stick to the blade;
- 3.unscrew the three or four screws i (Fig. n°49 ref.f), depending on the model, which fasten the blade;
- 4.rest the jig (b) on the blade, so that the split in the jig fits in the ring (Fig. n°47 ref.c);
- 5.match the axes of the two holes (Fig. n°49 ref.d) on the blade with the two-knobs(Fig. n°49 ref.e) on the jig, simply making the blade turn to the desired position;
- 6.screw the two knobs (e) without excessively tightening them.

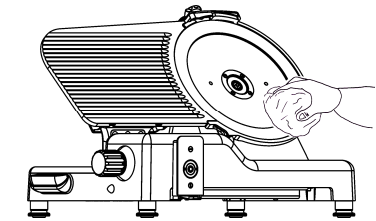

Fig. n°48

N.B. The bladeguard must be cleaned with warm water, the equipped detergent or with neutral detergent (pH 7).

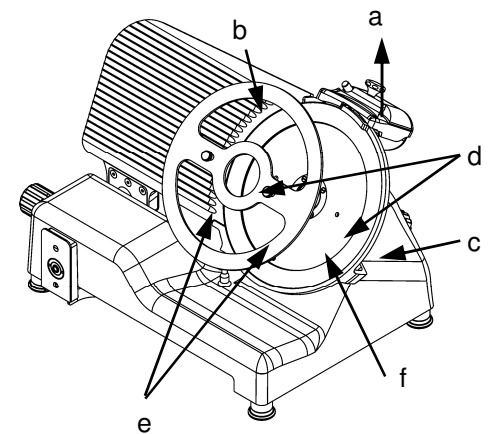
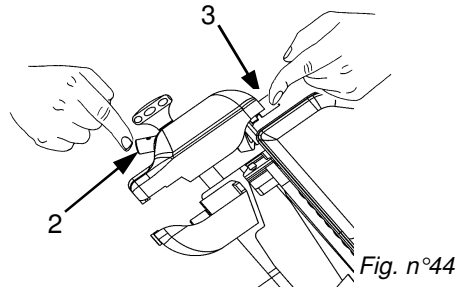

Fig. n°49

ders and the blade (**chapter 6.2.3**);
 9. once the operation is finished, replace the sharpening device in its original position, doing the procedure in reverse.



N.B.: Do not carry on the deburring operation for more than 3/4 sec. to avoid the damaging bending of the blade edge.

CHAP. 6 - ROUTINE CLEANING

6.1 - GENERALITIES

- Cleaning the machine must be carried out at least once a day or, if necessary, more frequently .
- All the parts of the slicer that come in direct or indirect contact with the food to be cut must be scrupulously cleaned.
- The slicer must not be cleaned with water cleaning machines or water jets, but with the product provided and/or with neutral detergents (pH 7). **The use of any other detergent is prohibited.** Utensils, brushes and whatever else could damage the machine surface must not be used.

Before carrying out any cleaning operation it is necessary to:

1. disconnect the plug from the electrical network to completely isolate the machine from the rest of the system;
2. Bring the graduated handgrip which regulates the thickness gauge to "0".

WARNING: Be careful of residual risks from sharp and/or pointed parts.

6.2 - CLEANING THE MACHINE

6.2.1 - Cleaning the goods holder plate

The trolley (plate + arm + stem) is easily transportable:

- bring the graduated handgrip to "0" (1 Fig. n°45);
- bring the trolley (2) to the end of its run (a) from the controls side; partially unscrew the plate lock handgrip (3), pull the trolley towards the operator; completely unscrew the plate lock handgrip, therefore lift the trolley up (b - Fig. n°45);
- having taken off the trolley, the goods holder plate can be carefully cleaned

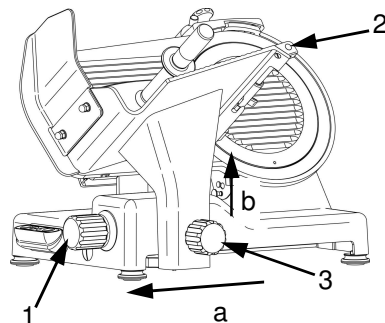

Fig. n°45



Do not expose the package to humidity or rain (Fig. n°4).

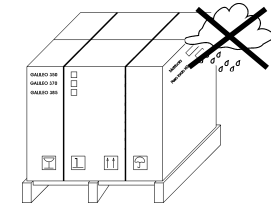

Fig. n°4



Heavy package. Do not lift manually unless with help of at least three people (Fig. n°5).

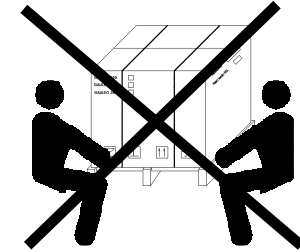

Fig. n°5



Move the package only by electrical trolleys or manually, equipped with lifting straps (Fig. n°6).

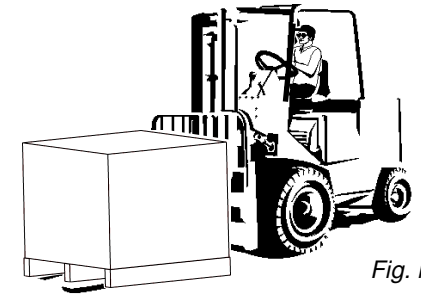

Fig. n°6



Since the center of gravity is not in the middle of the package, moving it suspended by chords or similar systems is not advisable (Fig. n°7).

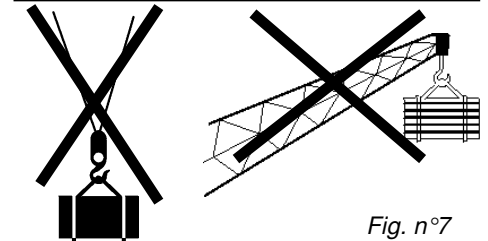

Fig. n°7

1.2 - CHECKING THE PACKAGE UPON DELIVERY

When the package is received, if there is no external damage proceed to opening it, making sure that all material is inside. If the package upon delivery shows signs of tampering (Fig. n°8), impact or fall, it is necessary to present the damage to the carrier, and within 3 days of the delivery date, indicated on the documents, make a precise report of the damage. Do **not over-**

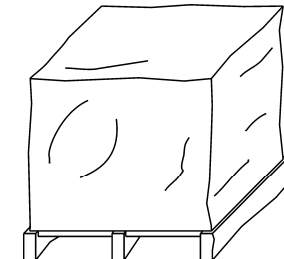

Fig. n°8

turn the package!! When transporting it make sure that it is firmly held by the four corners (keeping it parallel to the floor).

CHAP. 2 - INSTALLATION

! WARNING!

All operations must be carried out by specialized personnel (Fig. n°9).



Fig. n°9

2.1 - UNPACKING

Remove the straps from the package (Fig. n°10) and lift the cardboard (h).

The package should be:

- a) the machine on the pallet (Fig. n°11 detail a);
- b) blade extractor (Fig. n°11 detail b);
- c) 4 feet (Fig. n°11 detail c);
- d) kit case (Fig. n°11 detail d).
- e) Instruction booklet (detail e).

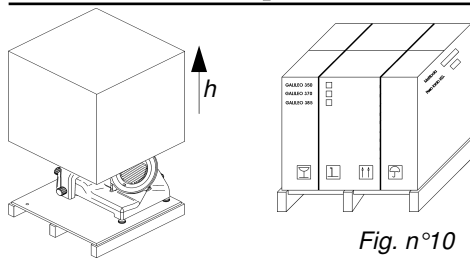

Fig. n°10

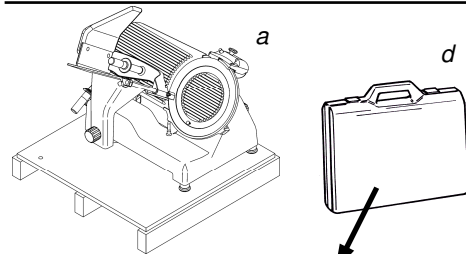
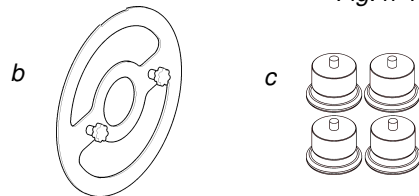

Fig. n°11



cutting effort increases (chapter 5.3).

5.3 - SHARPENING THE BLADE

WARNING: Before starting to sharpen the blade, pay attention to RESIDUAL RISKS (chapter 4.2.2) concerning the dangers of cutting without having followed the instructions listed below.

To sharpen the blade, which needs to be done periodically as soon a decrease in cutting is noticed, the following directions must be adhered to:

1. disinsert the plug from the outlet and carefully clean the blade with denatured alcohol so it is degreased;
2. lift (a) the sharpener (1) and turn it 180° (b Fig. n°42);

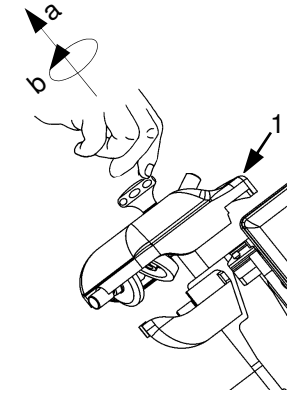

Fig. n°41

3. let it go in a way that the sharpener (c) fits on the locator pins (d Fig. n°42);
4. check also that the blade stays between the two grinders;

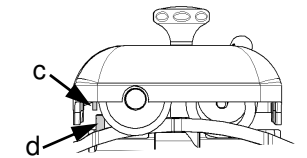

Fig. n°42

5. insert the pin and start the machine, by pressing the "ON" push-button;
6. press the push-button (2 Fig. n°43), let the blade rotate in contact with the grinder for about 30/40 sec. so that a slight burr forms on the blade edge;
7. press the 2 push-buttons (2 and 3) contemporaneously for 3/4 sec. and release them in the same instant (Fig. n°44);
8. after having completed the sharpening it is advisable to clean the grin-

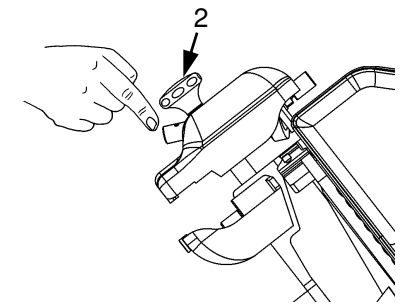

Fig. n°43

5.2 - LOADING AND CUTTING THE PRODUCT

WARNING: The goods to be cut are loaded on the plate only with the graduated handgrip at “0” and the motor stopped, being careful with the blade and the points.

Adhere to the following procedure:

1. Lift the goods presser, load the goods on the plate, bringing it close to the thickness gauge, block it with the proper toothed arm;
2. regulate the desired thickness of the cut with the graduated handgrip;
3. assume a correct position to avoid accident: place the right hand on the goods presser handgrip and, then the left hand next to the slice guard to take the cut product (**without touching the blade**); the body must be perpendicular to the work plane (Fig. n°38).

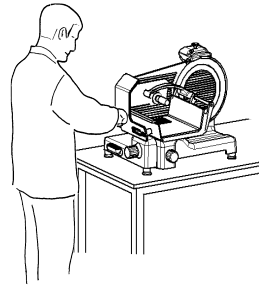

Fig. n°38

WARNING: Do not assume positions which bring body parts in direct contact with the blade (ex. Fig. n°39);



Fig. n°39

4. then push the “ON” push-button;
5. push the carriage (plate + goods presser arm + stem) gently towards the blade, without applying excessive pressure on the product with the goods presser arm. The goods will easily enter the blade, and the slice guided by the proper slice-guard will detach and fall on the plane (Fig. n°39);
6. avoid running the slicer when empty ;
7. at the end of the cutting operation, stop the machine by putting the switch in the “OFF” (ARREST) position and put the graduated handgrip at “0”;
8. Carry out resharpening the blade as soon as the cut product has a threaded or rough surface, therefore the

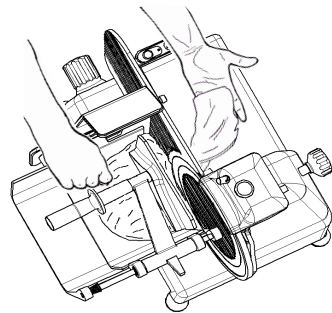

Fig. n°40

2.2 - POSITIONING

Position the pallet, with the slicer, on a flat surface and take off (a) the sharpener from the slicer (Fig. n°12).

At this point turn the machine on its side (Fig. n°13) and unscrew, with the proper wrench provided, the 4 nuts which fasten the slicer. Remove the 4 washers and unscrew the 4 fastening tie rods on the wooden pallet. Take off the pallet and fasten the 4 feet provided. Finally, put the sharpener in its place.

Position the slicer in the predestined place.

The dimensions indicated in Tab. 1-2-3 (according to the model) must be kept in mind for the plane where the slicer will be installed, therefore it must be wide enough, well-levelled, dry, smooth, robust, stable about 80 cm high off the ground and at least 20 cm from walls, objects, shelves, etc. (Fig. n°14) in respect to the space necessary for its use and safeguarding.

Furthermore the machine must be placed in an environment with a maximum humidity of 75%, not salty and with a temperature between +5°C and +35°C; in any case in environments which do not lead to deviations of the above.

Make sure the graduated handgrip is in position “0”.

Check the alignment of the blade-plane thickness gauge by running a finger (Fig. n°16) from the blade towards the thickness gauge plane (never in the opposite direction). Unscrew and screw the foot (1) until the correct alignment is found (Fig. n°17), then screw the rubber part (2) to fix everything (Fig. n°17).

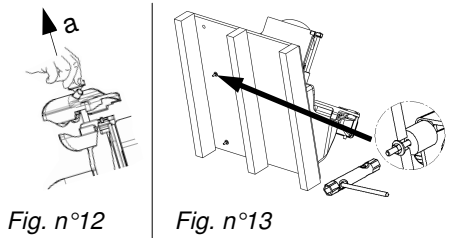

Fig. n°12

Fig. n°13

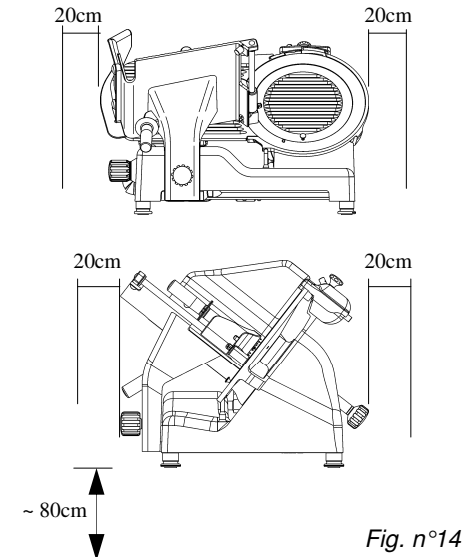

Fig. n°14

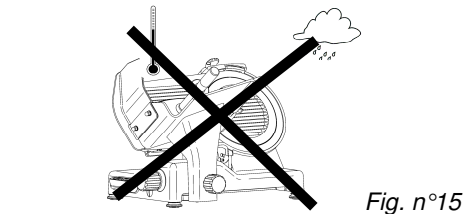

Fig. n°15

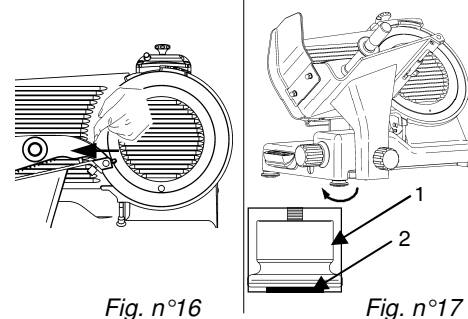

Fig. n°16

Fig. n°17

2.3 - ELECTRICAL CONNECTION

Check that the data reported on the technical-part number plate (*Fig. n°18*), the delivery documents and the order, correspond; contact the supplier for clarification if they do not.

At this point make sure that the system is standard and that the cable and grounding system perfectly operate.

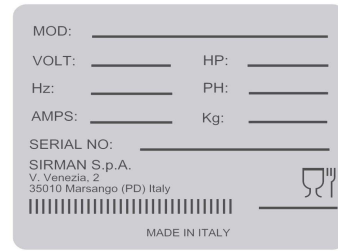

Fig. n°18

2.3.1 - Slicer with single-phase motor

The slicer is equipped with a feeding cable with a cross section area of AWG; length $\cong 1.5\text{m}$ and a "UL" plug. Connect the 120 V. - 60 Hz slicer, interposing a magnetothermic differential switch of 10A, $\Delta I = 0.03\text{A}$.

2.4 - 120 V. ELECTRICAL DIAGRAM SWITCH

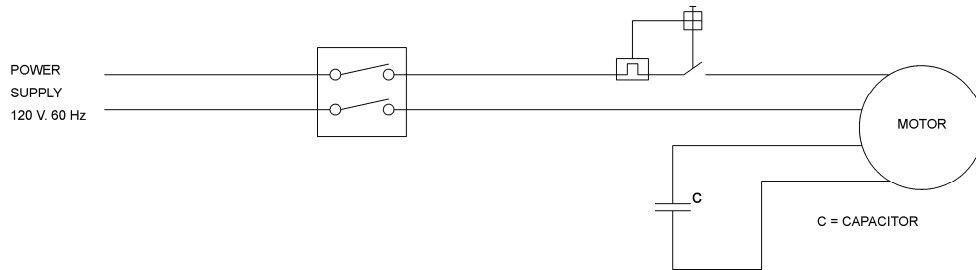

Fig. n°19

CHAP. 5 - MACHINE USE

5.1 - OPERATIONAL CHECK

For the 1° use follow these instructions:

- check that installation has been carried out correctly as in **chapter 2**;
- check that the plate is well fastened with the lock handgrip (*Fig. n°34 ref.1*);

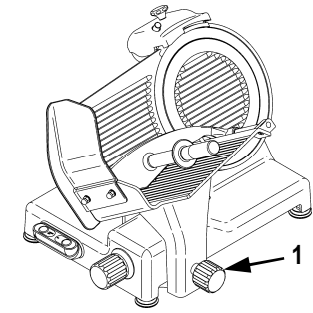

Fig. n°34

- check the sliding of the plate and that it is free of obstacles on the work counter for all of its run (*Fig. n°35 ref.a*);
- check that the goods pressing arm easily rises and lowers so that it is not impeded in all its movement (*Fig. n°35 ref.b*);

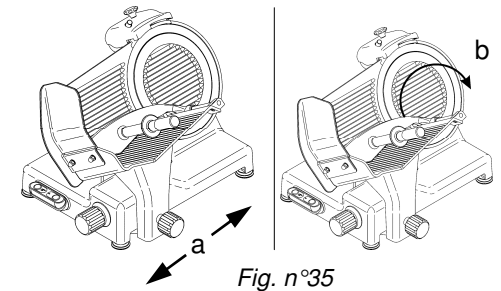

Fig. n°35

- check the opening of the thickness gauge plane by making the numbered handgrip turn clockwise and counter-clockwise (*Fig. n°36 ref.c*);

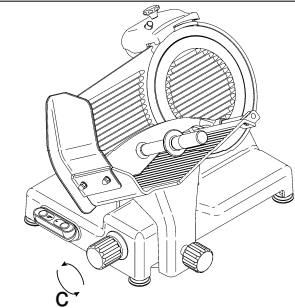

Fig. n°36

- check that the sharpener is well fastened to the machine and that it is easy to extract and free of obstacles (*Fig. n°37 ref.d*).

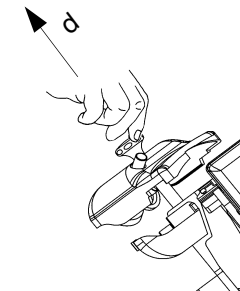

Fig. n°37

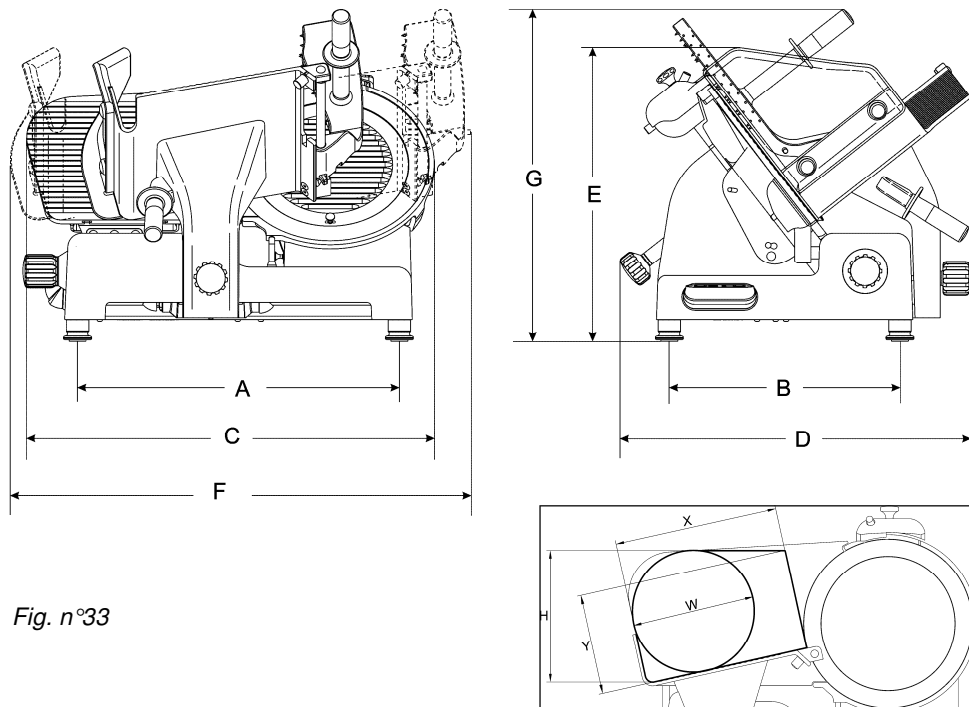

Fig. n°33

TAB. n°1 - DIMENSION MEASUREMENTS AND TECHNICAL FEATURES

Model	U.m.	mod. 300 - 330 - 350		
Diameter blade	mm	300	330	350
Motor	Watt/Hp	210/0,30	210/0,30	210/0,30
Motor INGR	Watt/Hp	400/0,54	400/0,54	400/0,54
Cut thickness	mm	30	30	30
Run of carriage	mm	310	310	310
Hopper	mm	305x270	305x270	305x270
A x B	mm	465x340	465x340	465x340
C x D x E	mm	615x547x465	645x570x455	660x575x455
F x D x G	mm	710x547x545	710x570x535	710x575x530
X Y H W	mm	270 190 240 220	270 210 260 240	270 230 275 255
Net weight	Kg	35	36	37
Power source	-	120V / 60 Hz		
Noise level	dB	≤ 60		

2.4 - 115 V. ELECTRICAL DIAGRAM , 'SIDNEY' PUSH-BUTTON

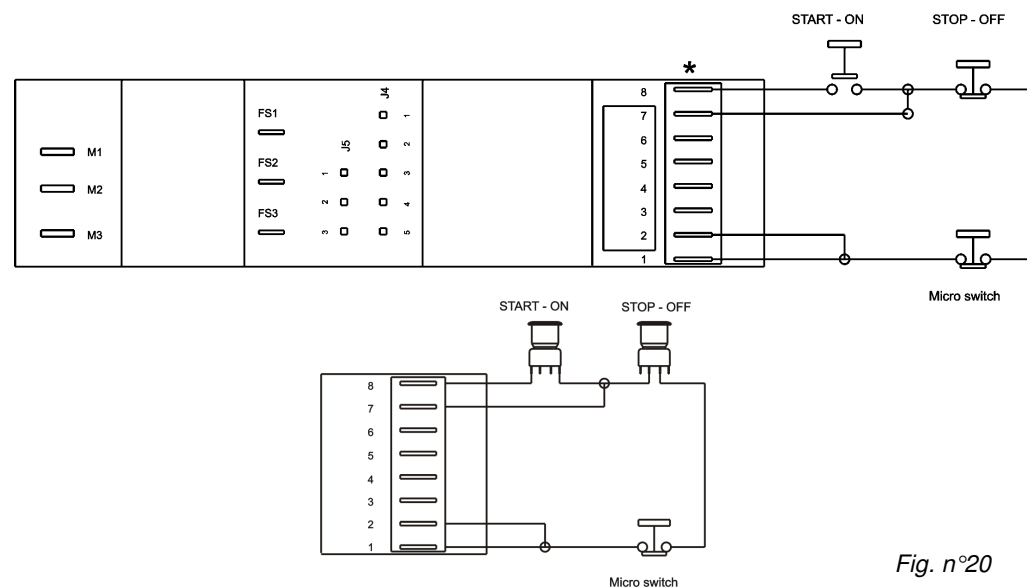

Fig. n°20

2.5 - PRELIMINARY CHECK

Before testing make sure the goods holder plate is well-blocked, after which test functioning with the following procedure:

- Push the "ON" and the "OFF"
- (ARREST) (Fig. n°21);
- check if by unscrewing the blade guard tie rod the machine stops working (Fig. n°30);
- Check if the machine does not start automatically by removing the plug and reinserting it while the machine is running..

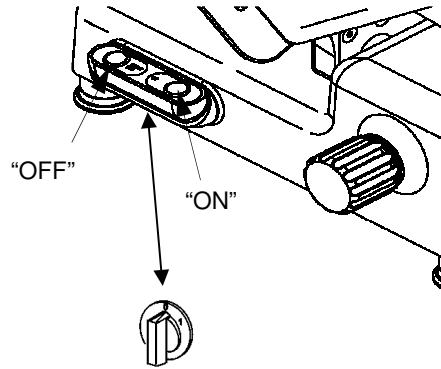

Fig. n°21

CHAP. 3 - INFORMATION ON THE MACHINE

3.1 - GENERAL PRECAUTIONS

The general precautions, even though they appear obvious, are fundamental for the installation, use, maintenance and possible inconveniences with their respective solutions.

- The slicer has been designed to cut fresh boneless meats and pork products (Fig. n°22). Any other use, including cutting vegetables, is considered inappropriate and therefore dangerous.
- The Manufacturer is not responsible in the following cases:
 - ⇒the machine is tampered with by unauthorized personnel;
 - ⇒components are substituted with unoriginal parts;
 - ⇒the instructions in this manual are not followed carefully;
 - ⇒the surfaces of the machine are treated with inappropriate products.
- Keep this manual in a safe place for future information or consultation (Fig. n°23).

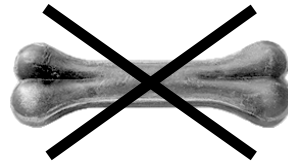

Fig. n°22



WARNING!



Fig. n°23

- A relay in the control circuit, that requires the machine to start up again in case of an accidental loss of electricity (Fig. n°32).

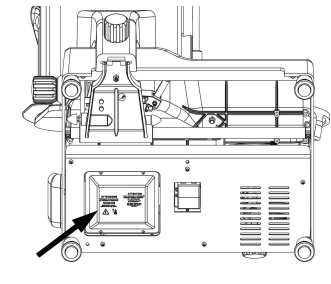

Fig. n°32

Even though the professional slicers are equipped with the standard measures for electrical and mechanical protection (both while operating and during cleaning and maintenance), **RESIDUAL RISKS** which cannot be completely eliminated in any case exist, highlighted in this manual under the form of **WARNING**. They concern the danger of cutting, bruising and other caused by the blade or by other machine parts.

4.3 - DESCRIPTION OF THE MACHINE

Professional slicers have been designed and made by our company with the precise purpose of cutting food products (like lunch meat and meats) and they guarantee:

- maximum safety in use, cleaning and maintenance;
 - maximum hygiene, thanks to a meticulous selection of materials that come in contact with the food products, and with the elimination of the edges in the parts of the slicer that come into contact with the product, in a way that it can be easily and totally cleaned not to mention easily disassembled;
 - maximum cutting precision thanks to the cam mechanism;
 - all components are robust and stable;
 - maximum silence thanks to the belt transmissions;
- very easy to handle.

4.4 - OVERALL DIMENSIONS, WEIGHT, FEATURES ...

WARNING:

The electrical features of the machine are shown on a plate on the back of the machine.

4.2 - SAFETY DEVICES INSTALLED ON THE MACHINE

4.2.1 - Mechanical safety

As far as mechanical safety is concerned, the slicer described in this manual responds to:

- **UL 763** machine directives;
- the **CSA 22.2** norm.

Safety is made possible by the:

- Thickness gauge plane
(Fig. n°30 ref. n°1);
- Ring
(Fig. n°30 ref. n°2);
- sharpener
(Fig. n°30 ref. n°3);
- Goods presser
(Fig. n°30 ref. n°4);
- Goods presser handgrip
(Fig. n°31 ref. n°5);
- handguard
(Fig. n°31 ref. n°6);
- Trolley transported only when thickness gauge plane is at "0", at the end of the run and towards operator side.

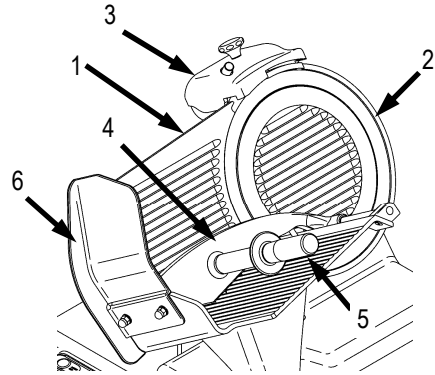

Fig. n°30

4.2.2 - Electrical safety

As far as electrical safety is concerned, the slicer described in this manual responds to:

- the **UL 763** norms;
- the **CSA 22.2** norms.

The slicer is therefore provided with:

- a microswitch on the blade cover that causes the machine to stop in case of the removal of the blade guard tie rod, and prohibits it from turning on if the device is not closed (Fig. n°31 - not available for INGR models);
- As far as hygienic safety is concerned The slicer described in this manual responds to **NSF Standard 51**.

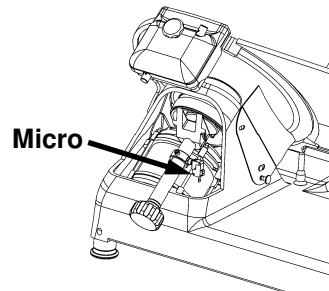

Fig. n°31

- The slicer must only be used by trained personnel who know the safety norms contained in this manual perfectly.

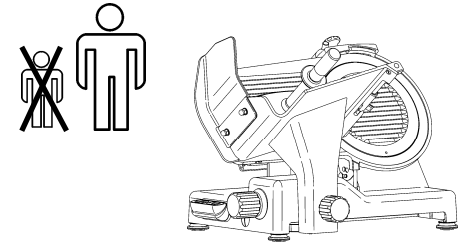

Fig. n°24

- In the case of an alteration in personnel, give time for training.

- Do not allow the slicer to be used by children or by untrained people (Fig. n°24).
- Before carrying out any cleaning or maintenance operation, disconnect the machine plug from the electrical network.
- When carrying out routine maintenance or cleaning of the slicer (and therefore the guards are removed), carefully evaluate the residual risks.
- During maintenance or cleaning stay concentrated on the operations.
- Do not use corrosive or flammable substances to clean the slicer (Fig. n°25); **only use the product provided**



ATTENZIONE!

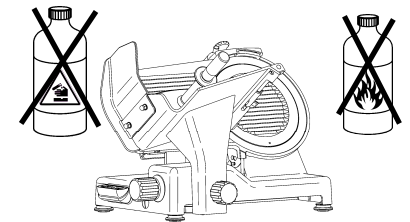

Fig. n°25

- To clean the slicer carefully follow the instructions in the chapter: "Routine cleaning".
- Do not wash the slicer in a dishwasher (Fig. n°26) or with water jets, do not immerse it in water or in other liquids.

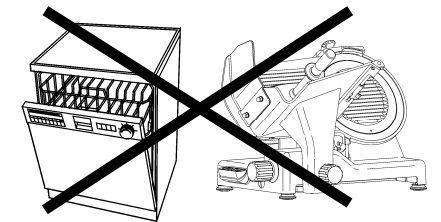

Fig. n°26

- Do not leave the slicer exposed to damaging agents: sun, rain, sprays, humidity, ice (Fig. n°27).

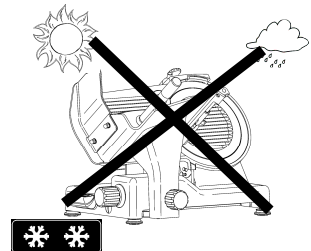

Fig. n°27

- Do not pull the slicer or the feeding cable (Fig. n°28) to unplug it.
- Regularly check the state of the feeding cable; a worn out cable or in any case not intact represents a serious electrical danger.
- If the machine remains unused for long periods of time, before using it again have it checked by a “Service Center”.
- If the slicer should show signs of malfunctioning it is advisable to turn it off and to not use it, to not directly intervene for repairs, and to contact the “Service Center”, shown on the back of this manual.
- Do not leave the slicer uselessly plugged in. Unplug the machine when it is not being used.
- Even if safety devices are installed on dangerous points of the machine, avoid placing hands near the blade and other moving parts.
- **Never cut the product, by now finished, without the aid of the goods pressing arm.**
- **Do not assume positions that bring body parts in direct contact with the blade.**

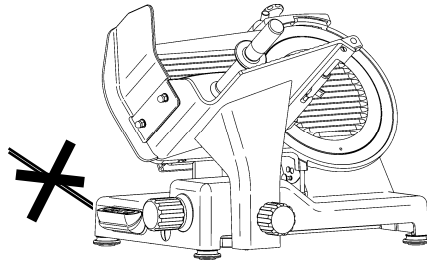

Fig. n°28

CHAP. 4 - GETTING TO KNOW THE SLICER

4.1 - CONSTRUCTION FEATURES

The slicer is made of an anodized aluminum alloy (Peraluman AlMg5). It guarantees contact with food-stuffs (hygienic) and is resistant to acids and salts apart being highly resistant to oxidation. The blade is in 100 Cr6 rectified, chromium-plated and hardened steel assuring a precise and net cut of the product even after being sharpened. The majority of the other components present are in:

- ABS;
- Shockproof plastic (handguard);
- AISI 430 or 304 steel.

LEGEND:

1	Sharpener handgrip	11	Blade protection
2	Sharpener	12	Base
3	Thickness gauge plane	13	Extractable pin
4	Handguard	14	Bladeguard
5	Push-button panel	15	Goods presser
5*	Switch	16	Goods presser handgrip
6	Foot	17	Bladeguard tie rod knob
7	Graduated handgrip	18	Sliceguard
8	Stem	19	Thickness gauge plane sharpener handgrip
9	Stem knob	20	Thickness gauge plane sharpener
10	Goods holder plate		

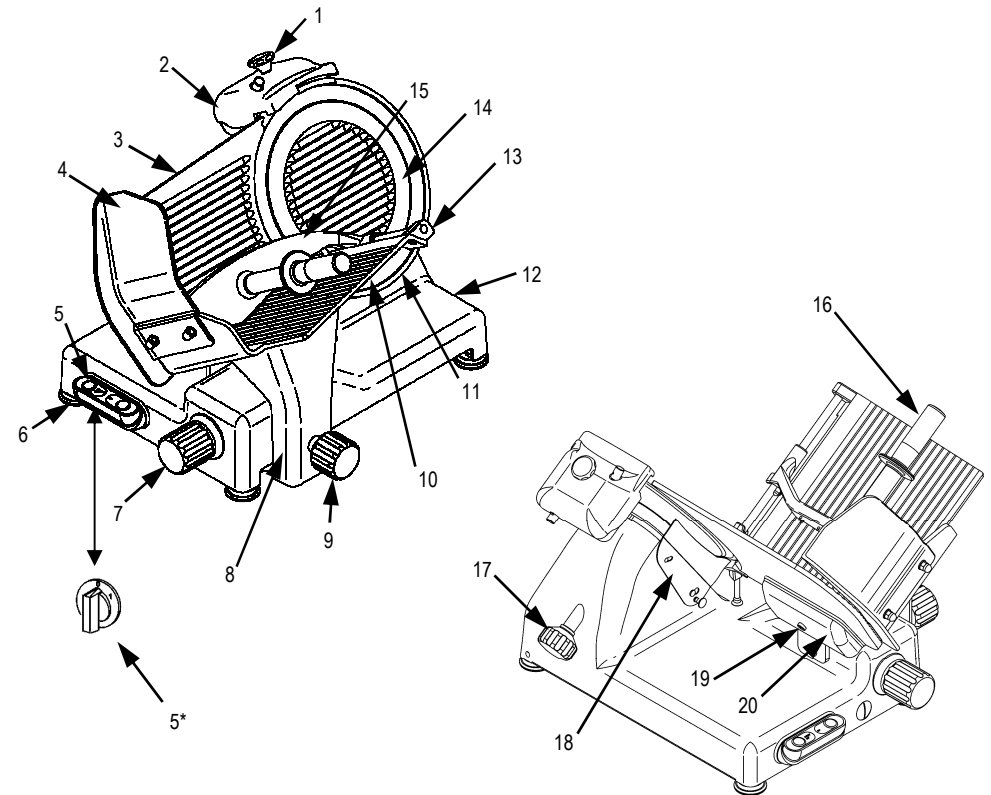

Fig. n°29