

2024

# User Manual



HKN-FXF50A

## Floor Gas Fryers

### Models:

HKN-FXF40A

HKN-FXF50A

HKN-FXF70A

### Note:

Please read this manual thoroughly prior to equipment set-up, operation, and maintenance.



 [www.equip.me](http://www.equip.me)

HURAKAN



## WARNINGS

- Do not store or use gasoline or other flammable vapors or liquids in the vicinity of this or any other equipment.
- Improper installation, adjustment, alteration, service or maintenance can cause property damage, injury or death.
- Read the installation and maintenance instructions thoroughly before installing or servicing this equipment.
- If you smell gas, follow the instructions provided by the gas supplier.
- Do not try to light the burner; do not use a telephone within close proximity.
- Have the equipment installed by a qualified installer in accordance with all federal, state and local codes.
- Do not install or use this equipment without all four legs securely in place.
- This equipment is designed for use only in non-combustible locations.
- Avoid obstructing the flow of combustion and ventilation air.
- Refrain from spraying liquids or cleaning agents on the controls or the exterior of the equipment.
- Place this equipment in a flat, level position during use.
- Do not operate the equipment without supervision.
- Any loose dirt or metal particles entering the gas lines can damage the valve and impact its operation.
- If you detect a gas odor, follow the instructions provided by the gas supplier. Do not attempt to light the burner, and avoid using a telephone in close proximity.
- Never attempt to move the machine while cooking.
- NEVER use an open flame to check for gas leaks, as it may result in fire and explosion.
- This fryer comes with a gas pressure regulator. Failure to install the supplied regulator properly may lead to an extremely hazardous condition. Ensure that the flow arrow stamped on the body of the regulator points toward the fryer, and the vent hole must point UP.
- If the pilot light is extinguished, turn off the gas shut-off valve, remove the grate and drip pan, and allow the appliance to vent for five minutes before attempting to re-light.
- **DO NOT** spill or pour water into burners or controls, and **DO NOT** submerge the fryer cabinet in water. Water damage to internal components is not covered by the warranty.
- **CAUTION** - Servicing must be conducted by factory authorized service personnel to minimize the risk of ignition from incorrect parts or improper service.

**Table of Contents**

---

Features & specifications .....	4
Installation instructions.....	4
Operating instructions and controls.....	12
Regular maintenance.....	14
Troubleshooting.....	15

---

**Instructions and images in this manual are only for reference and may differ from the actual product. Launch the E-Manual.**



## Features & specifications

FRYER CAPACITY					
Model	Burner Qty	Tank	BTU / Hour	Width Inch	Shortening lbs.
HKN-FXF40A	3	Single	90,000	15.5"	35-40
HKN-FXF50A	4	Single	120,000	15.5"	45-50
HKN-FXF0A	5	Single	150,000	21.0"	65-75

## Installation

**IMPORTANT! PLEASE READ BEFORE INSTALLATION:**

### Before installation

- Installation of this device should be carried out by professional technicians.
- Installation of this unit must adhere to the provisions of gas safety, installation, and usage.
- Verify that the electrical (if required) and gas supply match the specifications on the rating plate located inside the kick panel of the unit. If there's a discrepancy between the supply and equipment requirements, do not proceed with the installation. Contact your dealer immediately.
- The unit must be installed in a manner that ensures unobstructed flow of combustion and ventilation air. Ensure there's sufficient air supply in the room to facilitate proper combustion of gas at the burners.
- Maintain a minimum clearance of 12 inches from combustible materials at the sides and 10 inches at the rear. Clearance from non-combustible materials should be 0 inches at the sides and 6 inches at the back. Do not install on a flammable floor or near other combustible objects.
- This device is designed to be placed on a solid and level floor.

## **Unpacking**

This fryer was carefully inspected before leaving the factory. Upon acceptance of the shipment, the transportation company assumes full responsibility for safe delivery.

Immediately after unpacking the fryer, check for possible shipping damage. If the fryer is damaged, save the packaging material and contact the carrier immediately.

Check that the following items have been included:

- Crumb Rack
- Basket Hanger
- Twin Fry Baskets (2)
- Drain Pipe Extension
- Manual and Warranty – Retain for future reference.

## **Installation**

Do not use the door or its handle to lift the fryer.

Before installing the fryer, verify that the type of gas (natural or propane) conforms to the specifications on the fryer data plate, which is located on the inside of the door panel. Make sure the fryer is configured for the proper elevation.

## **Clearances**

- Minimum clearance from combustible construction:
  - 6" (15 cm) from the sides of the fryer
  - 6" (15 cm) from the back of the fryer
  - The fryer may be installed on combustible floors
- Minimum clearance from noncombustible construction:
  - 0" from the sides of the fryer
  - 0" from the back of the fryer
  - Between the fryer and any open-top flame units: 16" (41 cm)
  - Allow space for servicing and operation.

## **Location**

- Install the fryer in an area with sufficient air supply for gas combustion at fryer burners.
- Do not obstruct the flow of combustion and ventilation air.
- Provide adequate clearance for air openings into the combustion chamber.
- Do not permit fans to blow directly onto the fryer.
- Avoid wall-type fans, which create cross-currents within a room. Avoid open windows next to sides or back.



## Codes and standards

The fryer must be installed in accordance with:

In the United States:

- State and local codes, or in the absence of local codes, with:
  - National Fuel Gas Code, ANSI-Z223.1/NFPA #54 (latest edition). Copies may be obtained from The American Gas Association Accredited Standards Committee Z223, @ 400 N. Capital St. NW, Washington, DC 20001, or the Secretary Standards Council, NFPA, 1 Batterymarch Park Quincy, MA 02169-7471.
  - NFPA Standard #96 Vapor Removal from Cooking Equipment, latest edition, available from the National Fire Protection Association, Batterymarch Park, Quincy, MA.
  - National Electrical Code, ANSI/NFPA-70 (latest edition). Copies may be obtained from The National Fire Protection Association, Batterymarch Park, Quincy, MA. 02169-7471.
  - In the Commonwealth of Massachusetts, all gas appliances vented through a ventilation hood or exhaust system with a damper or with a power means of exhaust shall comply with 248 CMR.

In Canada:

- Local codes
  - CAN/CSA-B149.1 Natural Gas and Propane Installation Code (latest edition), available from the Canadian Standards Association, 155 Queen Street, Suite 1300, Ottawa, Ontario Canada K1P 6L1.
  - CSA C22.1 Canadian Electric Code (latest edition), available from the Canadian Standards Association, 155 Queen Street, Suite 1300, Ottawa, Ontario Canada K1P 6L1.

## Assembly

The fryer must be restrained to prevent tipping and the splashing of hot liquid. The means of restraint may be the manner of installation, such as connection to a battery of appliances, installing the fryer in an alcove, or by separate means such as adequate ties.

## Flue connection

Make the flue connection as follows:

- Comply with Vapor Removal from Cooking Equipment, ANSI-NFPA Standard #96 (latest edition), available from the National Fire Protection Association, Batterymarch Park, Quincy, MA 02269.
- Locate the fryer under a hood with adequate connection to an exhaust duct. The hood must extend 6" (15 cm) beyond the fryer on both sides.
- Clearance above the fryer should be adequate for combustion byproducts to be removed efficiently.
- An 18" (46 cm) minimum clearance should be maintained between the flue vent and the filters of the hood venting system.
- Never make flue connections directly to the fryer.
- Do not obstruct the flow of gases from the appliance. Proper air balance should be maintained in the room.
- Ensure that your ventilation system does not cause a downdraft at the fryer's flue opening. A downdraft will not allow the fryer to exhaust properly and will cause overheating, which may cause permanent damage. Damage caused by a downdraft will not be covered under equipment warranty. Never allow anything to obstruct the flue or ventilation exiting from the fryer flue. Do not put anything on top of the flue area.

## WARNING

**FLUE INSTALLATION: BEFORE USING FRYER, INSTALL AND ASSEMBLE THE 10-5/8" FLUE TO THE FRYER..**

1. Unpack the flue box and flue wrap.



2. Slide the flue box over the flue and secure it with the two self-tapping screws using a 5/16" socket.

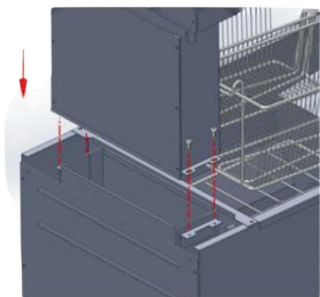

3. Slide the flue wrap over the flue. Secure it with self-tapping screws two on the back and two on the front using a 5/16" socket.

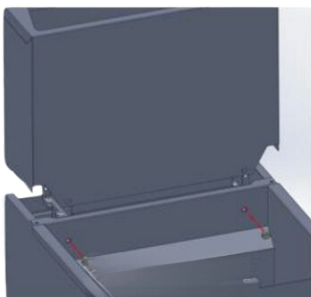
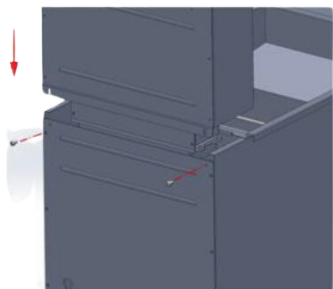



## **Gas connection**

All gas supply connections and any pipe joint compound must resist the effects of propane gases.

The gas inlet is located on the lower rear of the fryer. Codes mandate the installation of a gas shutoff valve in the gas line preceding the fryer.

The gas supply line must be at least equivalent to ½" (12.7 mm) iron pipe. If opting for the optional quick-disconnect flex hose, it should be ¾" (19 mm) iron pipe.

Ensure that the pipes are clean and clear of obstructions, dirt, and piping compound. A battery requires one or two connections of suitable size for the gas requirement.

Before lighting, inspect all joints in the gas supply line for leaks. Use a soap and water solution.

Do not utilize an open flame. After checking for leaks, thoroughly purge gas pipes to remove air.

## **Gas pressures (all models):**

Gas pressure should be set at 4" w.c. (water column) (0.8 kpa) for natural gas and 10" w.c. (2.75 kpa) for propane gas. If the incoming pressure exceeds ½ psi (3.45 kpa), an additional pressure regulator must be installed.

## **Testing the gas supply piping system:**

When test pressures exceed ½ psi (3.45 kpa), the fryer and its individual shutoff valve must be disconnected from the gas supply piping system.

When test pressures are ½ psi (3.45 kpa) or less, the fryer must be isolated from the gas supply piping system by closing its individual shutoff valve.

## **Fryers with casters:**

Separate instructions for installing casters are included with the casters:

- The installation should comply with the standard for connectors for movable gas appliances, ansi z21.69, can/cga-6.16, and a quick-disconnect device that complies with the standard for quick-disconnect devices for use with gas fuel, ansi z21.41 csa 6.9 or quick-disconnect devices for use with gas fuel.
- When installing a quick disconnect, you must also install a means for limiting the movement of the fryer. This device will prevent the gas line or quick disconnect from being strained. The restraining device should be attached to the cutout on the back panel. See illustration for location.



**A** Rear of Fryer

**B** Strain Relief Chain Connection  
(Chain supplied by others)

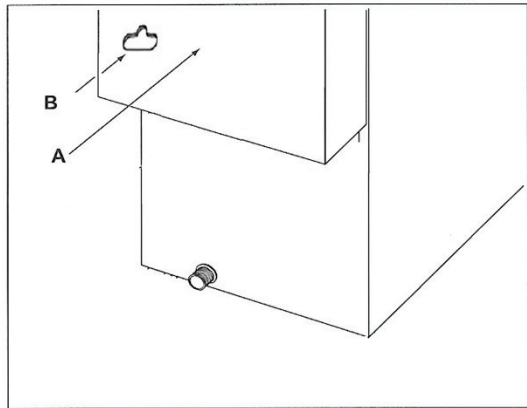

**Installation requirements:**

- The fryer must be installed using a connector (not provided by the factory) that adheres to the aforementioned codes.
- Ensure that the fryer is installed with proper restraining mechanisms to prevent strain on the connector. Refer to the illustration for guidance.
- The fryer must be installed using the supplied casters.
- Before disconnecting the restraint, turn off the gas supply. If reconnection of the restraint is necessary, ensure it's done after returning the fryer to its original position.

**Leveling the fryer:**

- After making gas connections, check the level of the fryer by placing a level on top of it.
- Ensure that the fryer is level both front-to-back and side-to-side in its final installed position.
- Lock the wheels once the unit is leveled.

**Operation:**

- Exercise caution when operating, cleaning, and servicing the fryer to prevent burns from hot oil and parts.
- Avoid moving the fryer without draining all frying compound from the tank to prevent spills and severe burns.
- Do not use the fryer during a power outage.

**Over-temperature shutdown:**

- If the shortening overheats, a high-temperature shutoff device will turn off the gas valve and extinguish the pilot.
- If the fryer shuts down due to overheating, refrain from relighting the pilot until the shortening temperature drops below 300°F (149°C).
- If overheating persists, contact your local authorized service office.

**Before first use:**

- **Cleaning:** New units are factory-wiped to remove visible dirt, oil, grease, etc. Before food preparation, wash all surface parts and the tank interior with hot soapy water to remove film residue, dust, or debris.
- Avoid using chlorine or sulfate/sulfide cleaners.
- Wash any accessories shipped with the unit.
- Thoroughly rinse the fryer and accessories, and then drain it.
- Wipe the tank completely dry with a soft, clean cloth.

**Filling tank with shortening:**

- Do not use solid shortening with this fryer, as melting it will damage the tank and void the warranty.

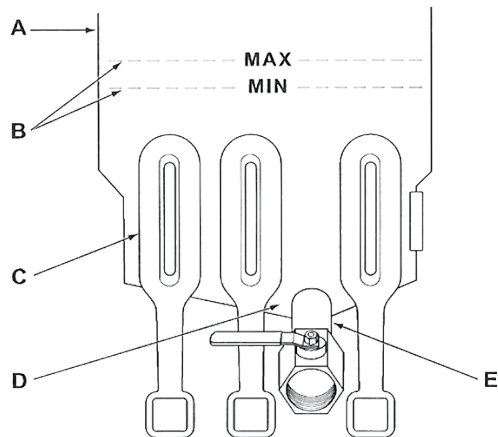
**A** Frying tank**B** Oil filling indicating line**C** Heating tube**D** Cold zone**E** Drain cock

- Close the drain valve.
- Fill the fryer tank with liquid shortening.
- Shortening level should be between the min and max lines in the fryer tank.
- Shortening will expand when heated. Do not fill the fryer tank over the MAX line.
- Add fresh shortening as needed to maintain oil level.

## Lighting the pilot

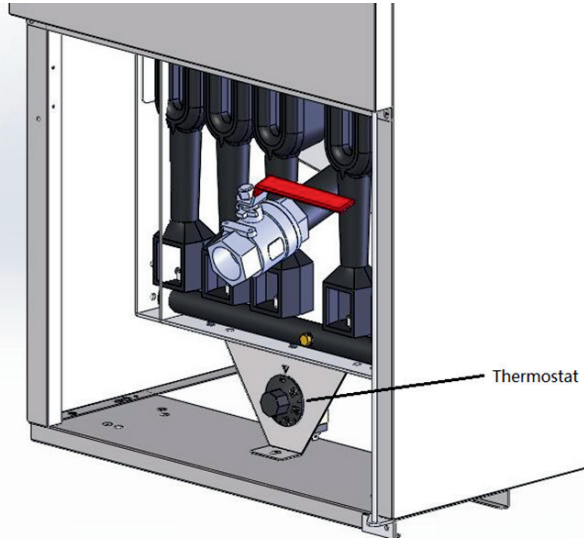

1. Open the door.
2. Make sure that thermostat is set to OFF. The thermostat is located behind the door.
3. Push the gas control valve knob and turn to OFF. Wait 5 minutes for unburned gas to vent.
4. Push and turn gas control valve knob to the "L" in PILOT (see figure below, view B).
5. While still holding the knob in, light the pilot with a lit flame. Continue to depress the knob until pilot remains lit when knob is released. If the pilot does not remain lit, repeat step 3 through 5.
6. Depress and turn gas control knob to ON (See figure below, view C).
7. If gas supply is interrupted, repeat steps 2 through 6.

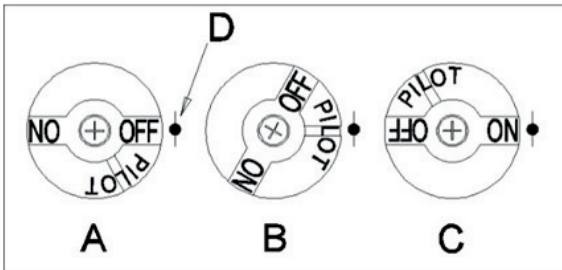

- A Gas Valve Knob, View A
- B Gas Valve Knob, View B
- C Gas Valve Knob, View C
- D Indicator Point, All Views

## OPERATING INSTRUCTIONS AND CONTROLS:



### Turning on the fryer

- Set the temperature knob to the desired temperature.
- Once the set temperature is reached, the thermostat shuts off the gas flow to the burners.
- The pilot remains lit, and the burners will cycle on and off to maintain the set temperature.

### Turning off the fryer

- Turn the thermostat off.
- To keep the pilot lit, turn the gas valve to "I" in pilot.
- To shut off all gas to the system, including the pilot, turn the gas valve knob to the off position.

### Extended shutdown

- Turn the thermostat knob to OFF.
- Push in the pilot knob and turn it to OFF.
- Thoroughly drain the fryer following the steps outlined in DRAINING THE FRYER.
- Clean the fryer according to the instructions in the CLEANING section.
- Turn off the main gas shutoff valve.

### Basic frying instructions

- Set the desired temperature and allow the shortening to heat up to that temperature.
- Fry items that are the same size to ensure even cooking.
- Drain or pat dry raw or wet foods to minimize splatter when lowering them into hot shortening.
- Add fresh shortening as needed.

### Fry basket guidelines

- Do not overfill baskets. Refer to the table below for recommended basket capacities. Carefully lower the basket into the oil.
- When frying doughnuts and fritters, turn the product only once during frying.
- When cooking French fries or onion rings, shake the basket several times.
- Batter-covered foods should be dropped carefully, one by one, into the shortening or basket. If using the basket, dip it into the shortening first to reduce batter buildup.
- After frying is completed, remove the basket or product and hang the basket on the rear hanger.

### Fry basket capacity:

- GF35: Recommended pounds per basket are 1.5 lbs. (0.7 kg).
- GF45: Recommended pounds per basket are 2.5 lbs. (1.1 kg).
- GF65: Recommended pounds per basket are 3.0 lbs. (1.4 kg).
- GF85: Recommended pounds per basket are 3.5 lbs. (1.6 kg).

## Extending shortening life

You can extend the life of the shortening by following these guidelines:

- Do not salt foods over the fryer.
- Use good-quality shortening.
- Filter the shortening daily at a minimum.
- Replace the shortening if it becomes poorly flavored.
- Keep the equipment and surroundings clean.
- Set the thermostat correctly.
- Remove excess moisture and particles from food products before placing them in the fryer.

## Draining the oil

Hot oil and hot parts can cause burns. Use caution when operating, cleaning, and servicing the fryer.

1. Turn the thermostat knob to the OFF position.
2. Insert the drain extension into the drain valve and tighten it hand tight.
3. Direct the drain extension into the mobile filtering device you want to use.
4. Slowly open the drain valve to allow the oil to flow from the fry tank to the filter pan, then open the drain valve fully.
5. Brush to remove any additional debris when the fry tank is empty.
6. Close the drain valve.
7. Fill the tank with new shortening, ensuring it is filled to at least the MIN level but no higher than halfway between MIN and MAX, as oil expands when heated.
8. After filling the fry tank with new oil, set the thermostat knob to the desired temperature. The burners will heat the oil.

## Cleaning

Hot oil and hot parts can cause burns. Use caution when operating, cleaning, and servicing the fryer.

Daily:

- Clean all exterior surfaces of your fryer at least once daily using a cleaning brush, damp cloth, and polish with a soft dry cloth. Neglecting regular cleaning may result in grease burning on and discolorations forming.
- Minimize fingerprints on stainless steel surfaces by applying a cleaner that leaves a thin oily or waxy film.
- Use a damp cloth with warm water and mild soap or detergent for cleaning. Do not use chlorine or sulfate/sulfide cleaners.
- Rinse thoroughly, then polish with a soft dry cloth.
- Keep the fryer exterior clean and free of accumulated grease to prevent stubborn stains. Remove discolorations with detergent or soap and water, using a non-metallic scouring pad for stubborn stains, and always rub with the grain of the stainless steel. Avoid using metallic scouring pads or harsh cleaners.

## Boil out procedure

Weekly or as required:

- Drain the tank as described under DRAINING THE TANK.
- Flush out scraps and sediment using a cleaning brush once the shortening has been drained.
- Close the drain valve and fill the tank with water. Use a low foaming cleaner/degreaser to clean the fry tank, following the instructions on the package.
- Ensure the solution level is between the MIN and MAX levels on the fryer tank. Do not use chlorine or sulfate/sulfide cleaners.
- Set the temperature knob to 200°F or the recommended solution temperature. Allow the solution to simmer for about 15 to 20 minutes.
- Drain the cleaning solution from the tank.
- Close the drain valve and refill the tank with water, adding 1 cup (1/4 L) of vinegar to neutralize alkaline left by the cleaner. Ensure the solution level is between the MIN and MAX level on the fryer tank.
- Bring the solution to a simmer only, then turn the thermostat off. Allow it to stand for a few minutes.
- Drain the tank according to DRAINING THE TANK. Rinse thoroughly with clear, hot water to remove all traces of cleaner. Dry the tank thoroughly.
- Close the drain valve and add shortening. Follow the FILLING TANK WITH SHORTENING procedure in this manual to complete the process. The fryer is now ready for use.

## Maintenance

Hot oil and hot parts can cause burns. Use caution when operating, cleaning, and servicing the fryer.

Spilling hot fryer compound can cause severe burns. Do not move the fryer without draining all frying compound from the tank.

## Flue vent inspection

When the fryer is cool, inspect the flue annually. Check for and clear any obstructions.

## Troubleshooting

Problem	Possible Cause
No Heat	Thermostat dial not turned on. Pilot not lit.
	Gas supply not turned on.
	Wire connections loose (call service).
	Wires connections need cleaning (call service).
	Thermopile (call service)
Insufficient or too much heat	Thermostat dial not set to desired temperature.
	High limit tripped (call service).
	Temperature probe (call service)
Tank will not drain	Shortening too cold.
	Drain pipe clogged with debris.

**ETL Sanitation**

This product has been certified by ETL, a division of the Intertek Group, to meet applicable sanitation standards required for use in the United States and Canada.

**ETL, US**

This product has been certified by ETL, a division of the Intertek Group, to meet applicable electrical product safety standards required for use in the United States.

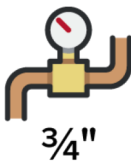
**3/4" Gas Connection**

This unit comes with a 3/4" gas connection to be installed by a professional.





# Heavy Duty Gas Griddles

Manual & thermostatic



# HURAKAN