

INSTALLATION MANUAL

FlavorFusion with Cold Carbonation

DESCRIPTION

The FlavorFusion series of dispensers solves your ice and beverage service needs in a sanitary, space saving, economical way. Designed to be manually filled with ice from any remote ice-making source, these dispensers will dispense cubes (up to 1-1/4 inch in size), cubelets, and compressed (not flaked) ice. In addition, the units include beverage faucets, a cold plate, an internal carbonator tank and an external pump for the carbonator, and are designed to be supplied direct from syrup tanks with no additional cooling required.



CAUTION: Dispenser cannot be used with crushed or flaked ice. Use of bagged ice which has frozen into large chunks can void warranty. The dispenser agitator is not designed to be an ice crusher. Use of large chunks of ice which “jam up” inside the hopper will cause failure of the agitator motor and damage to the hopper. If bagged ice is used, it must be carefully and completely broken into small, cube-sized pieces and left to “temper” or warm up for a minimum of 20 minutes in room temperature before loading into the dispenser hopper.

SPECIFICATION

Model Descriptions:	B=Beverage C=Coldplate H=Internal Cold Carb Z=No Drip Tray
Ice Storage:	255 Pounds
Maximum Number of Faucets Available:	4 nozzles with 4 brands each = 16 brands 2 nozzles with 4 bonus flavors each = 8 bonus flavors
Built-in Cold Plate:	Yes
Electrical:	120/1/60, 9.3 Amps of Total Unit Draw 220/1/50, 4.7 Amps of Total Unit Draw
Dimensions:	30 inch 30-11/16 inch 39 inch (to top of bin) 41-10/16 inch (to top of lid) Z-Models 30 inch 23-1/16 inch 39 inch (to top of bin) 41-10/16 inch (to top of lid)
CO ₂ Operating Pressure	75-psig (max) for carb tank and brand syrup pumps 25-psig (max) for bonus flavor pumps

SAFETY INSTRUCTIONS

Read and Follow all Safety Instructions

Read and follow all safety instructions in this manual and on the machine (decals, labels, and laminated cards).

Read and understand all applicable OSHA (Occupation Safety and Health Administration) safety regulations before operating the machine.

Recognize Safety Alerts



This is the safety alert symbol. When you see it in this manual or on the machine be alert to the potential of personal injury or damage to the machine.

Different Types of Alerts

There are 3 types of safety alerts:



DANGER — Indicates an immediate hazardous situation which if not avoided **WILL** result in serious injury, death, or equipment damage.



WARNING — Indicates a potentially hazardous situation which, if not avoided, **COULD** result in serious injury, death, or equipment damage.



CAUTION — Indicates a potentially hazardous situation which, if not avoided, **MAY** result in minor or moderate injury or equipment damage.

Safety Tips

- Carefully read all safety messages in this manual and safety signs on the machine.
- Keep safety signs in good condition and replace missing or damaged safety signs.
- Learn how to operate the machine and how to use the controls properly.
- Do not let anyone operate the machine without proper training. This appliance is not intended for use by very young children or infirm persons without supervision. Young children should be supervised to ensure that they do not play with the appliance.
- Keep your machine in proper working condition and do not allow unauthorized modifications to the machine.

Qualified Service Personnel



CAUTION — Only trained and certified electrical, plumbing and refrigeration technicians should service this unit. **ALL WIRING AND PLUMBING MUST CONFORM TO NATIONAL AND LOCAL CODES.**

CO₂ (Carbon Dioxide) Warning



WARNING — CO₂ Displaces Oxygen. Strict Attention **must** be observed in the prevention of CO₂ gas leaks in the entire CO₂ and soft drink system. If a CO₂ gas leak is suspected, particularly in a small area, **immediately** ventilate the contaminated area before attempting to repair the leak. Personnel exposed to high concentration of CO₂ gas will experience tremors which are followed rapidly by loss of consciousness.

Shipping And Storage



CAUTION — Before shipping, storing, or relocating the Unit, syrup systems must be sanitized and all sanitizing solution must be purged from the syrup systems. All liquids, after sanitizing, must be purged from the unit. A freezing ambient environment will cause residual sanitizing solution or water remaining inside the Unit to freeze resulting in damage to the internal components.

INSTALLATION

IMPORTANT: TO THE INSTALLER.

It is the responsibility of the installer to ensure that the water supply to the dispensing equipment is provided with protection against backflow by an air gap as defined in ANSI/ASME A112.1.2-1979; or an approved vacuum breaker or other such method as proved effective by test.

Water pipe connections and fixtures directly connected to a potable water supply shall be sized, installed, and maintained according to Federal, State, and Local laws.

1. Locate the dispenser indoors on a level counter top.
 - A. LEG OPTION
Unpack the four (4) legs and install them into the threaded holes provided in the bottom of the unit. The installer must provide flexibility in the product and utility supply to permit shifting the position of the dispenser sufficiently to clean the area beneath it.
 - B. COUNTER MOUNTING
The ice drink dispenser must be sealed to the counter. The template drawing (see FIGURE 6) indicates where openings can be cut in the counter. Locate the desired position for the dispenser, then mark the outline dimensions on the counter using the template drawings. Cut openings in counter.

Apply a continuous bead of *NSF International* (NSF) silastic sealant (Dow 732 or equal) approximately 1/4-inch inside of the unit outline dimensions and around all openings. Then, position the unit on the counter within the outline dimensions. All excess sealant must be wiped away immediately.

2. The beverage tubes, drain tube and power cord are routed through the large opening in the bottom of the unit. See the MOUNTING TEMPLATE (FIGURE 6) for locating the required clearance opening in the counter for these utility lines.
3. DRIP TRAY DRAIN ASSEMBLY (see FIGURE 7): Route the drain tube to an open drain with the end of the tube above the "flood" level of the drain. Use the tubing, fittings, clamps, and insulation provided with the Dispenser to assemble the drain. The completed drain line *must* pitch continuously downward and contain no "traps" or improper drainage will result.

NOTE: IMI Cornelius Inc. recommends that a water shutoff valve and water filter be installed in the plain water inlet supply line. A Cornelius Water Filter (P/N 313860000) and QUICK DISCONNECT SET (P/N 313867000) are recommended.



CAUTION: Check the minimum flow rate and the maximum pressure of the plain water inlet supply line. MINIMUM FLOW RATE MUST BE AT LEAST 125-GALLONS PER HOUR. If flow rate is less than 125-gallons per hour, starving off the carbonator water pump will occur. Starving will allow the carbonator water pump to overheat causing the safety thermostat on the pump outlet to stop the water pump motor. Overheating could occur if the plain water supply line flow rate drops below 125-gallons per hour. INCOMING PLAIN WATER INLET SUPPLY LINE WATER TO PUMP PRESSURE MUST REMAIN A MINIMUM OF 10 psi BELOW THE CARBONATED CO₂ OPERATING PRESSURE. (Example: Carbonator CO₂ operating pressure is 75 psi and the maximum water pressure can be no more than 65 psi, etc.). Water over pressure (higher CO₂ operating pressure) can cause carbonator flooding, malfunction, and leakage through the carbonator relief valve. If water is exceeding maximum pressure specifications, a Water Pressure Regulator Kit must be installed in the plain water inlet supply line. If fitting connector is not available, tap into the plain water supply line with a 3/8 flare saddle valve.

4. Locate the carbonator pump assembly and connect to power cord from the Ice/Drink Unit to the pump. The cord is connected to the unit's electrical box and has an electrical connector on the end that plugs into a receptacle in the junction box at the carbonator pump assembly. Connect inlet water to pump and pump outlet to Ice/Drink Unit using 3/8-inch food-grade tubing. Disable the pump from operating by switching the switch in the carbonator pump assembly junction box to the OFF position.
5. Connect the beverage system product tubes as indicated in applicable Flow Diagram FIGURE 8. This work should be done by a qualified service person.

NOTE: See applicable Flow Diagram (see FIGURE 8) or Decal on the lower front of the unit for the location of syrup and water connections.

6. Clean the hopper interior (see CLEANING INSTRUCTIONS in Owner's Manual).
7. Connect the unit power cord to a 120 volt, 60 cycle, 3-wire grounded receptacle. For 220-240 Volt International Units, a 3-wire power cord is provided. An adapter plug for the particular country will need to be provided by the Installer.

ADJUST CARBONATOR CO₂ REGULATOR AND TURN WATER INLET SUPPLY LINE ON

CAUTION: Before connecting the CO₂ regulator assembly to a CO₂ cylinder, turn the regulator adjusting screw to the left (counterclockwise) until all tension is relieved from the adjusting screw spring.

1. Open (counterclockwise) CO₂ cylinder valve slightly to allow lines to slowly fill with gas, then open the valve fully to back-seat the valve. (Back-seating the valve prevents leakage around the valve shaft).
2. The carbonator CO₂ regulator is fixed at a nominal 75 psi.
3. Open one of the post-mix dispensing valves to exhaust trapped air inside the carbonator tank.
4. Open the water inlet supply line shutoff valve.

UNIT OPERATION



WARNING: The unit must be electrically grounded to avoid possible fatal electrical shock or serious injury to the operator. The unit power cord is equipped with a three-prong plug. If a three-hole (grounded) electrical outlet is not available, use an approved method to ground the unit.

CAUTION: Never operate the carbonator pump with the water inlet supply line shutoff valve closed. "Dry running" the water pump will burn out the pump. A pump damaged in this manner is not covered by warranty.

1. Connect electrical power to the Unit.
2. Locate the switch on the junction box of the carbonator pump, and turn it ON. The water pump will start and fill the carbonator tank with carbonated water. The water pump will stop when the carbonator tank is full.
3. Check for water and CO₂ leaks, and tighten any loose connections
4. Dispense several drinks until the carbonator pump cycles on. The refill time should be about 5-7 seconds.
5. If the carbonator pump appears to be short-cycling, meaning a refill time of 1-2 seconds, refer to the Troubleshooting section.

GATE RESTRICTOR PLATE AND ADJUSTMENT

The rate at which ice is dispensed can be adjusted by varying the opening of the gate restrictor plate as illustrated in FIGURE 1. Reducing the dispense rate of ice is especially desirable when using glasses or other containers with small openings. To adjust the gate restrictor plate, loosen the (4) nuts that hold the ice chute assembly to the bin. The restrictor plate can now be moved up or down. When the restrictor plate is fully up, the ice gate opening is 2-1/2" in height, and the maximum rate of ice dispense is available (approximately 3 oz/sec). Retighten the (4) nuts to set the desired restrictor plate opening. **DO NOT EXCEED 40 IN-LB of torque.**



DISCONNECT POWER BEFORE INSTALLING, REMOVING, OR ADJUSTING RESTRICTOR.

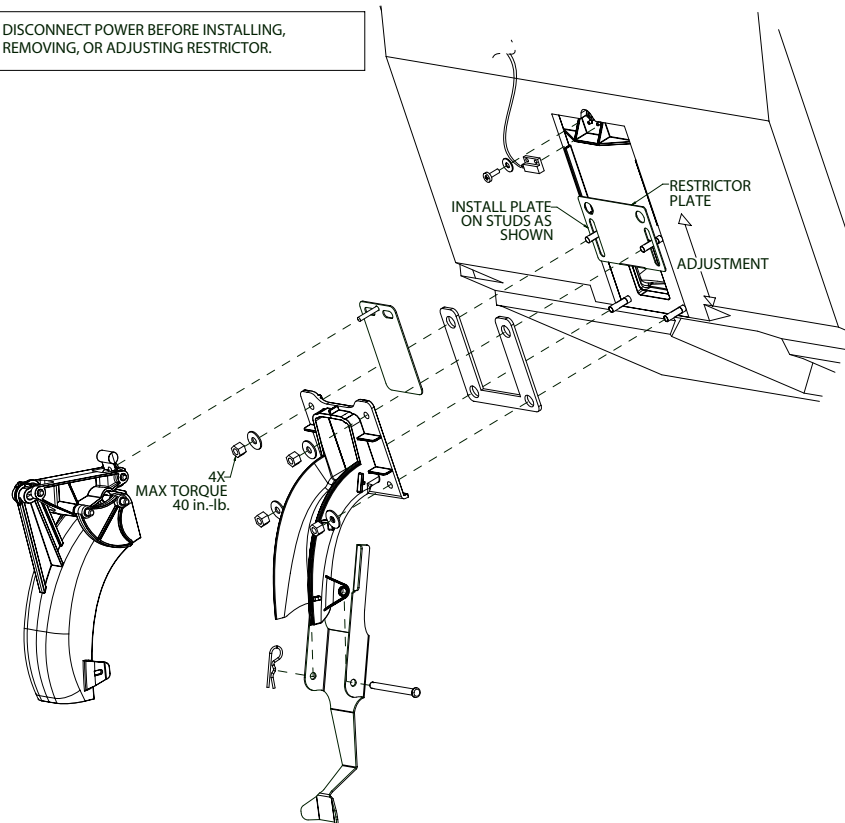

FIGURE 1. Gate Restrictor Plate

NOTE: Tighten (4) nuts for fastening lower ice chute in place to 40 in-lbs (max). Draw all four nuts tight uniformly.

PROGRAMMING MODE

The programming mode is exactly the same for both brand and bonus keypads.

To enter the programming mode, press and hold the two program buttons (see FIGURE 4) at the top of the keypad for approximately 4 seconds. All keypad LEDs will flash off for approximately 1 second to indicate the start of the programming mode.

To exit programming mode, press and hold the two program buttons for approximately 4 seconds. All keypad LEDs will flash off for approximately 1 second, resuming normal operation mode.

Programming Mode Flashing Sequences

Once in programming mode, each dispense button LED flashes in a sequence cycle according to one (1) of six (6) dispense types. For Brand Keypads, only dispense types 1 and 2 are used. For Bonus Flavor Keypads, dispense types 3 through 6 are used. The six (6) dispense types are described below, and shown in a timing diagram in FIGURE 2:

- **Dispense Type 1, Carbonated water dispense:** Solid LED
- **Dispense Type 2, Non-carbonated dispense:** Flashing LED 1.5 seconds ON, 1.5 seconds OFF
- **Dispense Type 3, 1-second flavor shot:** LED flashes once for $\frac{1}{4}$ second, followed by 3 seconds OFF
- **Dispense Type 4, 2-second flavor shot:** LED flashes twice for $\frac{1}{4}$ second ON, $\frac{1}{2}$ second OFF, followed by 3 seconds OFF
- **Dispense Type 5, 3-second flavor shot:** LED flashes three (3) times for $\frac{1}{4}$ second ON, $\frac{1}{2}$ second OFF, followed by 3 seconds OFF
- **Dispense Type 6, 4-second flavor shot:** LED flashes four (4) times for $\frac{1}{4}$ second ON, $\frac{1}{2}$ second OFF, followed by 3 seconds OFF

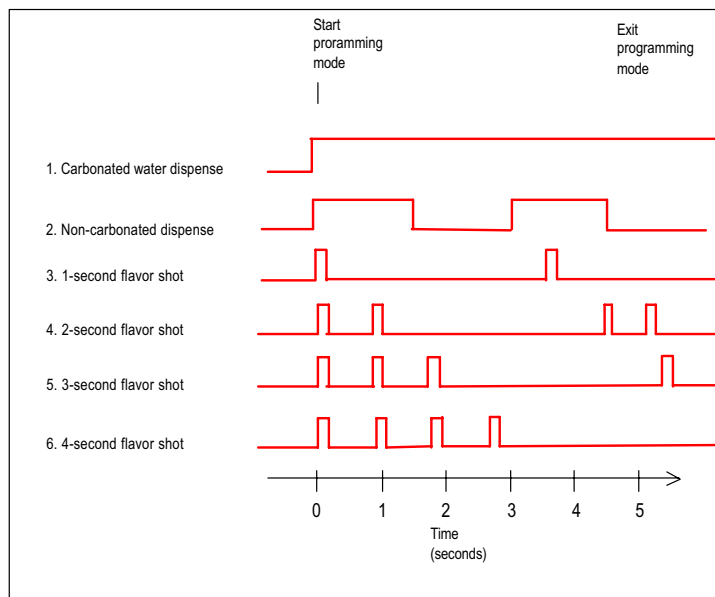

FIGURE 2

Setting Water Flow Rate

Setting the water flow rate will require a timed dispense. To accomplish this, the following procedure should be followed:

1. Enter programming mode for the valve block by simultaneously pressing and holding both programming buttons for 4 seconds (see FIGURE 4). The LED's for flavors 1-4 should flash off and then back on. The drink icon should turn off.
2. Set the valve block to a 4 second pour mode by simultaneously pressing and holding Flavor 1 and Flavor 4 buttons until the flash pattern for all four buttons changes.
3. Place an empty ratio cup under the appropriate nozzle and press the left program button for a 4 second dispense of carbonated water. There should be approximately 10 oz. dispensed.
4. If necessary, adjust the water flow control (see FIGURE 3), empty ratio cup, and repeat step 3. Otherwise empty ratio cup and repeat step 3 using the right program button for plain water.
5. Exit 4 second pour mode by simultaneously pressing and holding Flavor 1 and Flavor 4 buttons until the flash pattern for all for buttons changes.
6. Exit programming mode by simultaneously pressing and holding both programming buttons for 4 seconds.

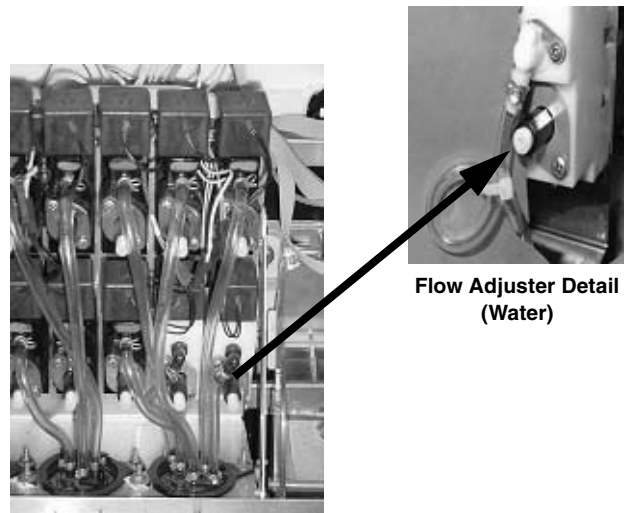

FIGURE 3. Valve with Flow Adjusters
(see plumbing diagram for plumbing and valve configuration)

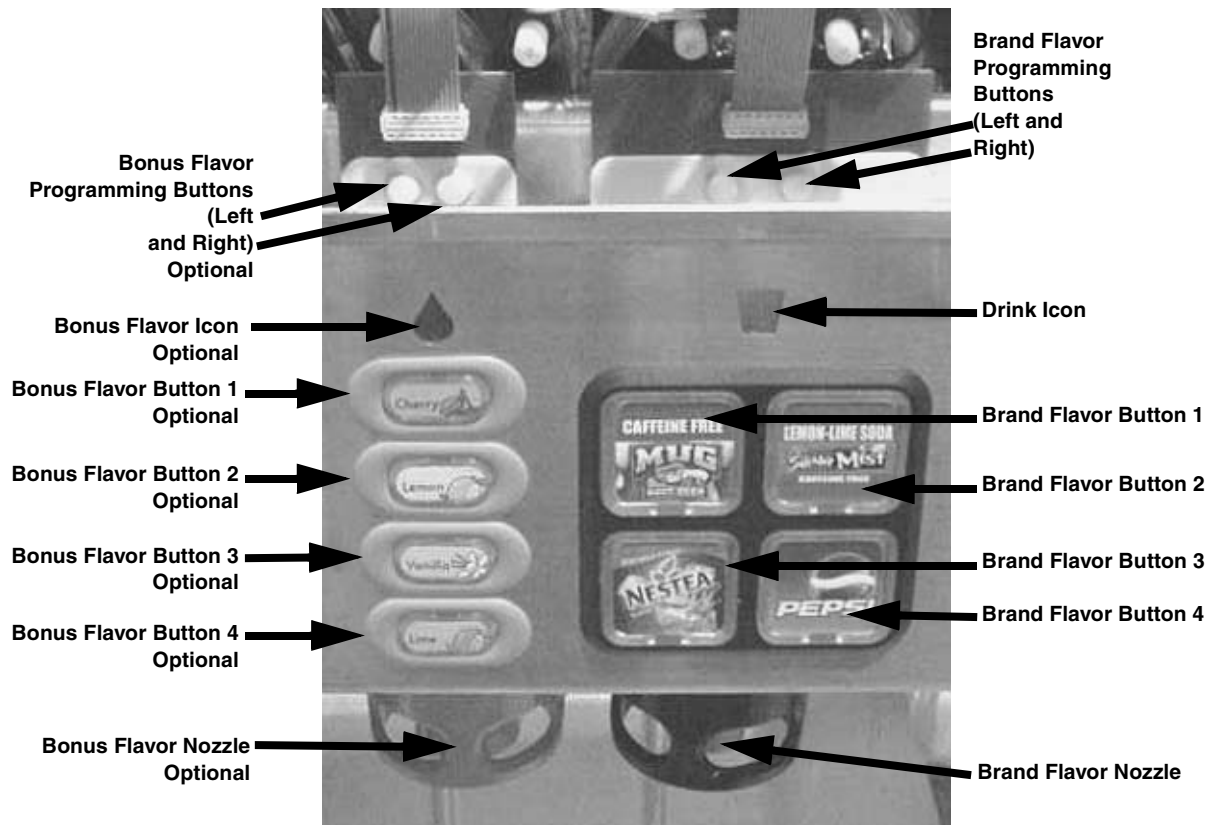

FIGURE 4

Adjusting Syrup/Water Ratio (Brix)

Timed Dispense Procedure

1. Enter programming mode for the valve block by simultaneously pressing and holding both programming buttons for 4 seconds (see FIGURE 4). The LED's for flavors 1-4 should flash off and then back on. The drink icon should turn off.
2. Set the valve block to a 4 second pour mode by simultaneously pressing and holding Flavor 1 and Flavor 4 buttons until the flash pattern for all for buttons changes.
3. Place the water end of the ratio cup under the appropriate nozzle and press the left program button for a 4 second dispense of carbonated water. (Push the right program button for still water pour.)
4. Place the syrup end of the ratio cup under the nozzle and press the appropriate flavor button for a 4 second dispense of syrup. The fill line should be the same for both water and the syrup. Adjust the syrup flow control if necessary, then empty cup and repeat steps 3 and 4.
5. Repeat for all syrups in valve bank.
6. Exit 4 second pour mode by simultaneously pressing and holding Flavor 1 and Flavor 4 buttons until the flash pattern for all for buttons changes.
7. Exit programming mode by simultaneously pressing and holding both programming buttons for 4 seconds.

Setting a Button to Dispense Non-carbonated Water Only

1. Program the designated button to dispense non-carbonated water (see Programming Mode.)
2. Do not connect a syrup source to the inlet circuit of the designated button (1-14 or A1-A2.) If circuit 1 through 14 is chosen leave the coldplate inlet circuit plugged with the red cap. If circuit A1 or A2 is chosen, plug the end of the inlet tube with a red cap from the coldplate, or with tape.

Setting a Button to Dispense Carbonated Water Only

1. Program the designated button to dispense carbonated water (see Programming Mode.)
2. Do not connect a syrup source to the inlet circuit of the designated button (1-14 or A1-A2.) If circuit 1 through 14 is chosen leave the coldplate inlet circuit plugged with the red cap. If circuit A1 or A2 is chosen, plug the end of the inlet tube with a red cap from the coldplate, or with tape.

NOTE: The ambient circuits A1 and A2 do not give up a cold plate circuit.

Back Room Package Position (BRP)

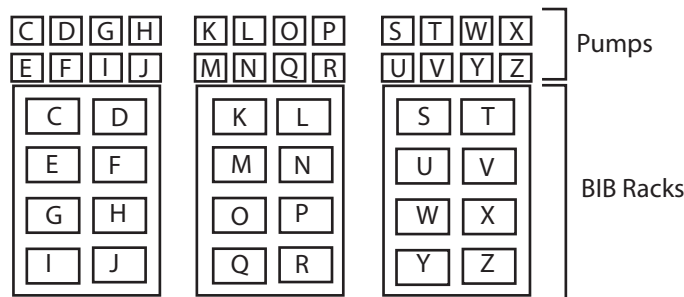
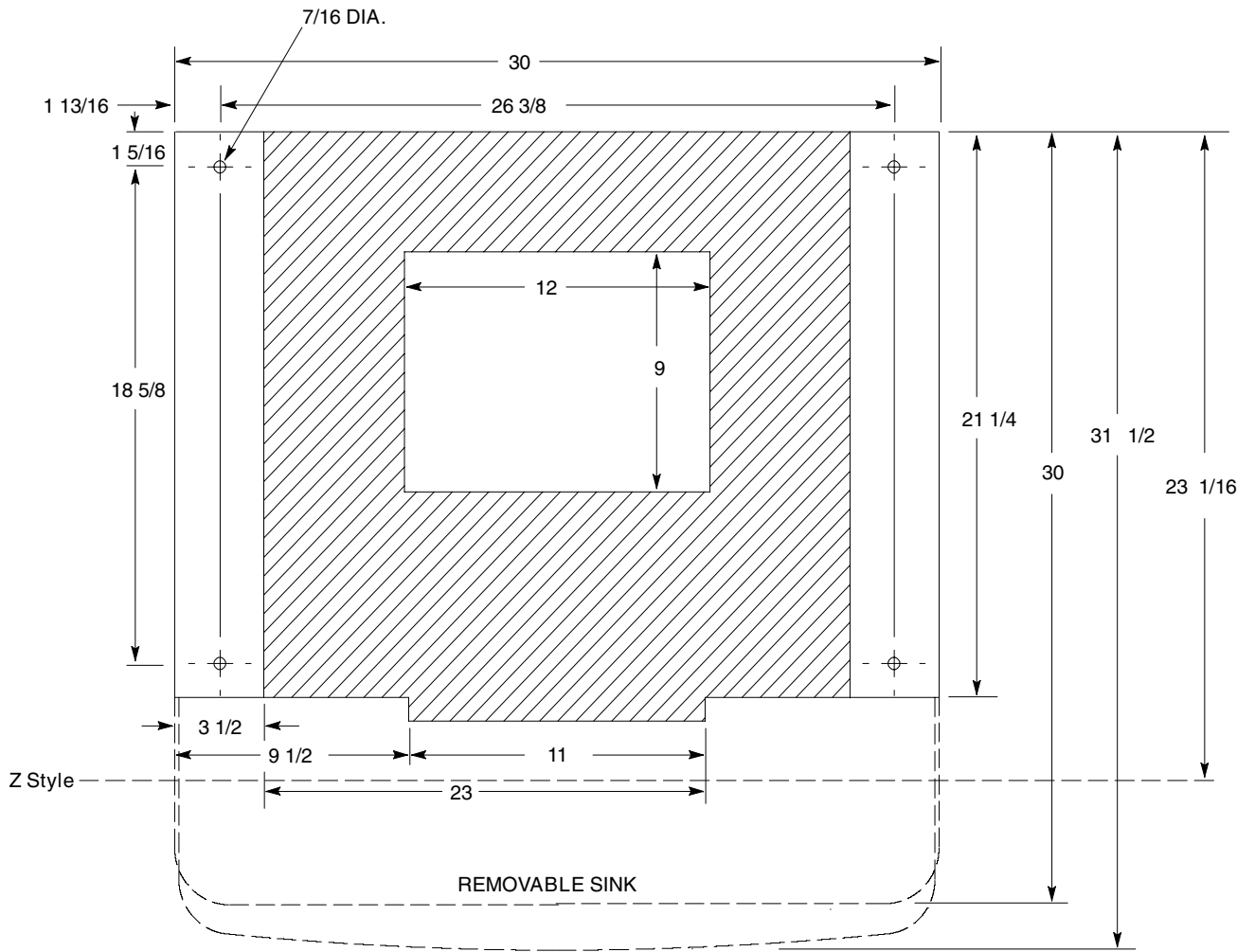

FIGURE 5

MOUNTING TEMPLATE



RECOMMENDED COUNTER OPENING SIZE
 9 X 12 FOR UTILITIES AND BEVERAGE
 TUBING. OPENING CAN BE LOCATED
 ANYWHERE WITHIN SHADED AREA.

FIGURE 6. FlavorFusion Mounting Template

DRIP TRAY DRAIN ASSEMBLY

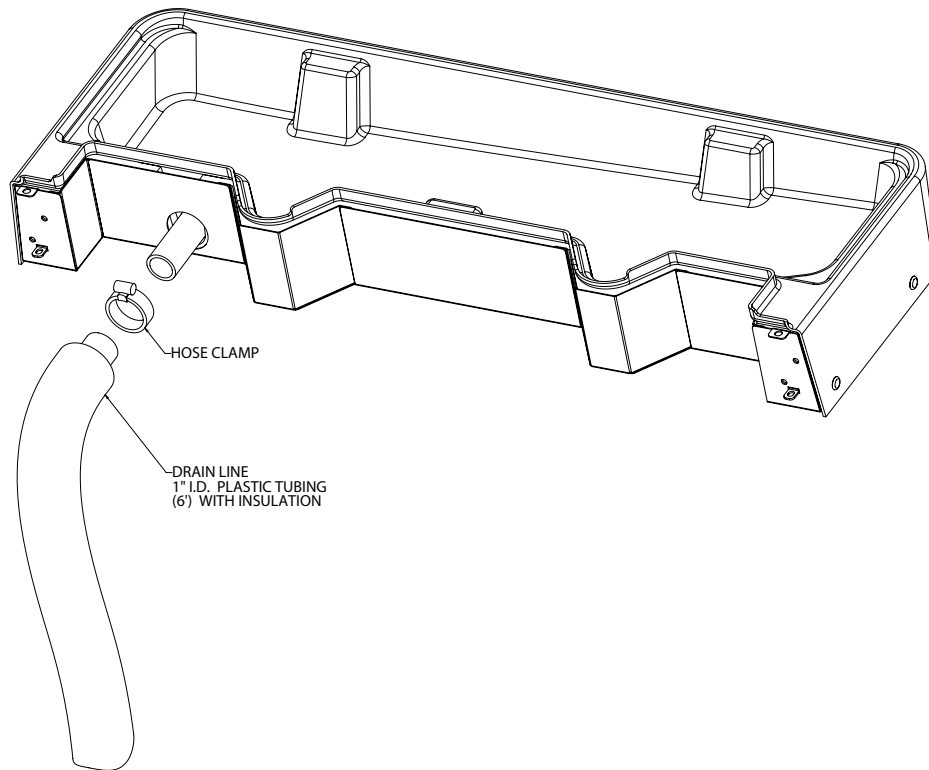

FIGURE 7. Drip Tray Drain Assembly

DIAGRAMS

Flow Diagram

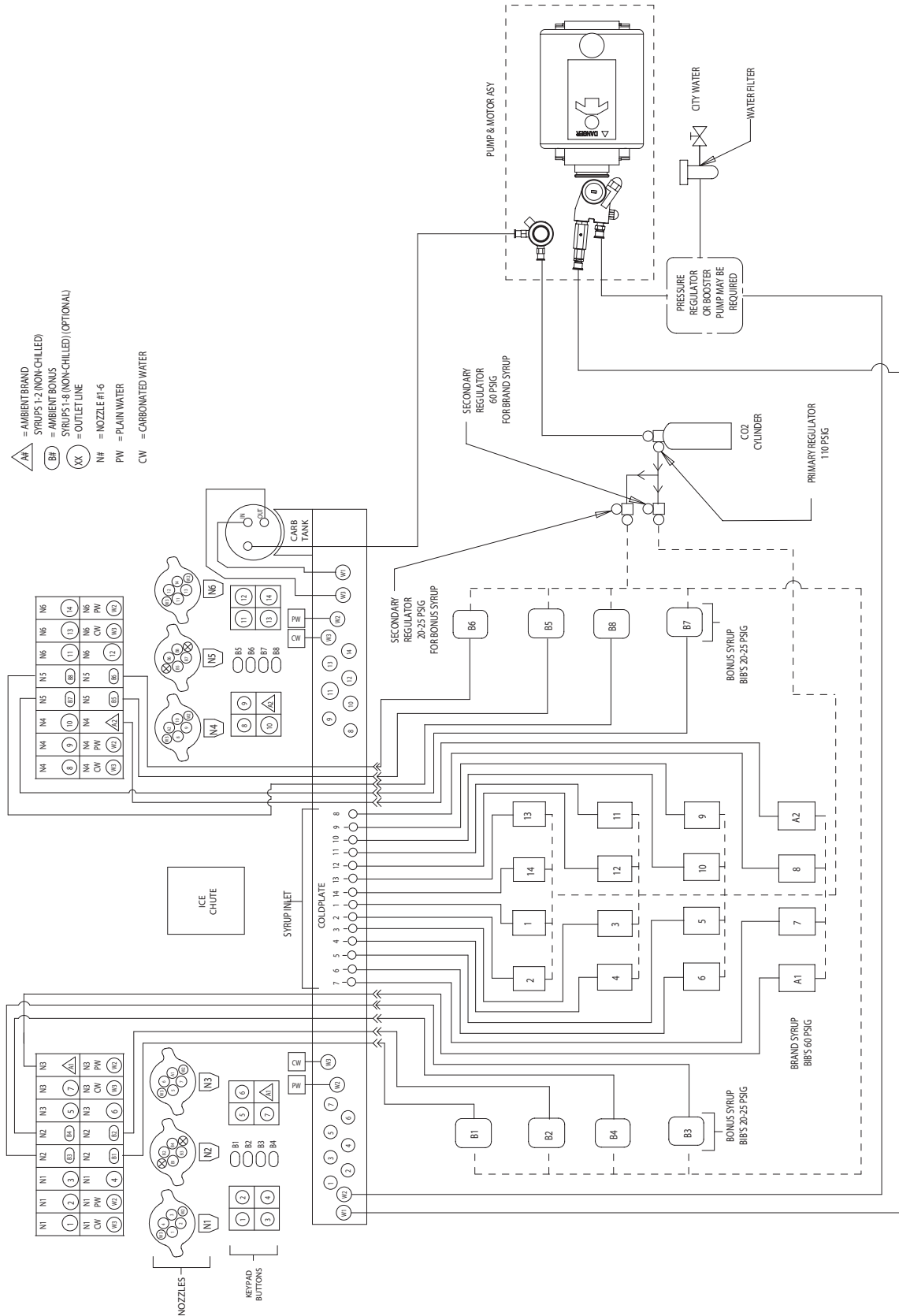

FIGURE 8. Flow Diagram

Wiring Diagram

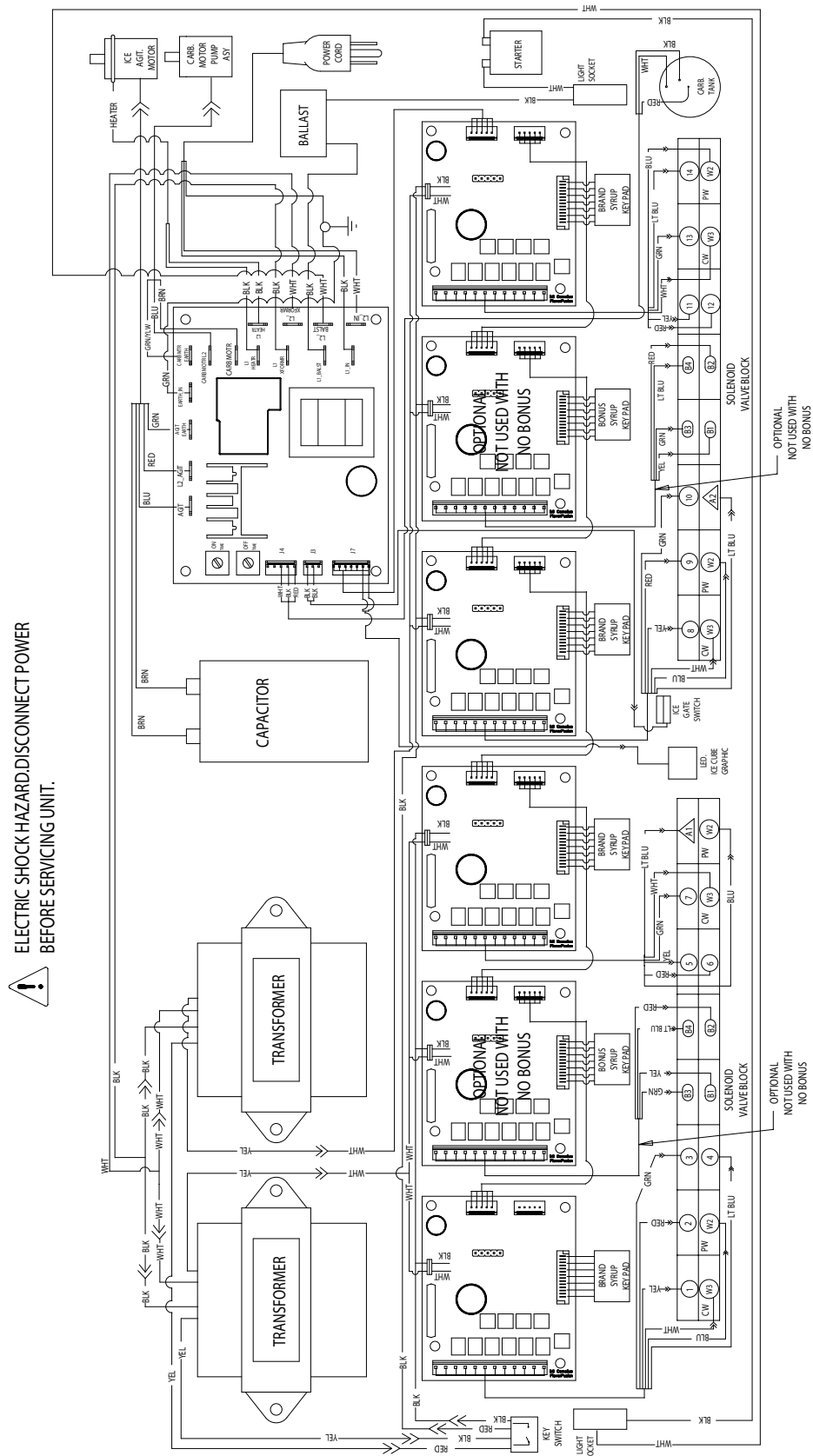

FIGURE 9. Wiring Diagram - 120V Unit

Wiring Schematic

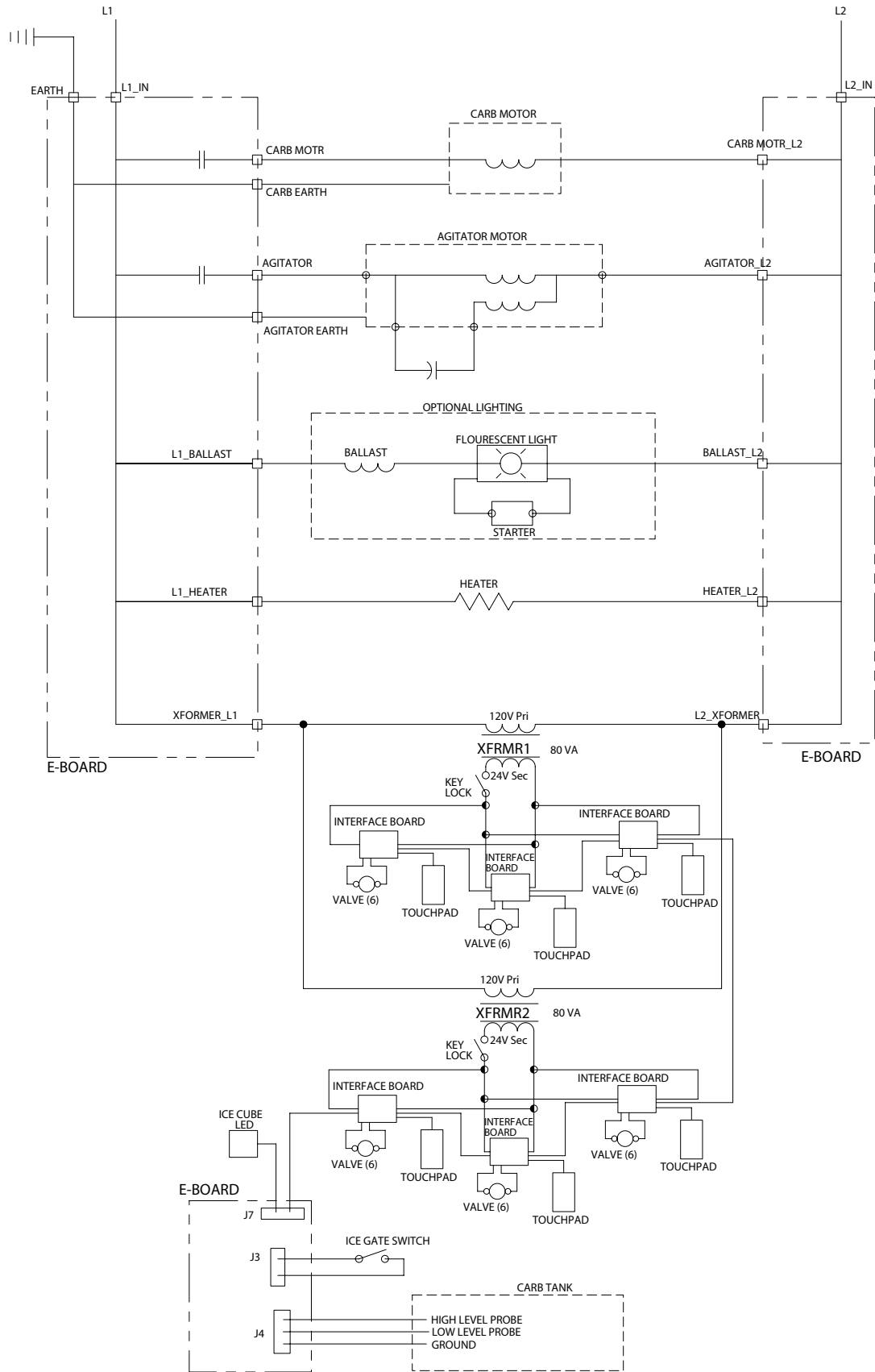

FIGURE 10. Wiring Schematic

TROUBLESHOOTING

IMPORTANT: Only qualified personnel should service internal components or electrical wiring.



WARNING: If repairs are to be made to a product system, remove quick disconnects from the applicable product tank, then relieve the system pressure before proceeding. If repairs are to be made to the CO₂ system, stop dispensing, shut off the CO₂ supply, then relieve the system pressure before proceeding. If repairs are to be made to the refrigeration system, make sure electrical power is disconnected from the unit.

Should your unit fail to operate properly, check that there is power to the unit and that the hopper contains ice. If the unit does not dispense, check the following chart under the appropriate symptoms to aid in locating the defect.

Dispenser Troubleshooting		
Symptom	Cause	Remedy
Blown fuse or circuit breaker	Short circuit in electrical wiring	Repair Wiring
	Inoperable agitator motor (shorted motor)	Replace gear motor
Agitator does not turn	No power	Restore power or plug in unit
	Improperly installed upper ice chute assembly (Reed switch is not being activated)	Check the upper ice chute assembly for proper assembly and operation
	Inoperable reed switch	Replace reed switch
	Electrical board driver circuit is defective	Replace main control board
	Gear motor has open circuit	Replace gear motor
	Reed switch is not activated Improper assembly of upper ice chute to lower chute.	Check to make sure tongue of upper chute engages into the back of the lower chute, ensure upper chute engages outside the lower chute, and snap front of chute into place.
	Broken wire in the 2-wire harness leading to the reed switch	Repair or replace 2-wire harness
	Bad connection at main control board, J3, pins 2 &3	Repair connection or replace 2-wire harness
Ice dispenses continuously	Ice gate mechanism is stuck in open position	Inspect gasket for proper position. Examine gate plate to see if it slides freely behind the lower ice chute.
	Stuck or bent ice lever (does not allow gate to close and open reed switch)	Examine ice dispense lever to see if it is bent.
Slushy ice or water in hopper	Blocked drains in cold plate	Remove access covers in cold plate cover & inspect/clean drains
	Poor ice quality due to water quality or ice maker problems	Correct water quality or repair ice maker



Beverage does not dispense	No 24VAC to valves	Restore 24 VAC to valves
	No CO ₂ pressure	Restore CO ₂ pressure
Beverage is too sweet	Valve brix requires adjustment	Adjust valve brix
	Carbonator is not operating	Repair carbonator
	No CO ₂ in carbonator	Restore CO ₂ pressure in carbonator
	City water pressure supply low or inconsistent	Booster pump must be used if dynamic water pressure drops below 40 psig.
Unit will not dispense carbonated drinks. Dispenses syrup only.	CO ₂ pressure in carbonator tank is too high.	Check CO ₂ pressure regulator setting. 75 psig recommended. Relieve pressure from carbonator tank.
	Water valve will not open	Check electrical connection to water valve. Check resistance of coil (should be 9 ohms). Check for voltage at coil when brand button is depressed.
Unit will not dispense carbonated drinks. Spurts CO ₂ and syrup only.	Carbonator tank is empty, because tank was emptied while power was applied to unit. 5 minute time-out of carbonator pump/motor occurred, and carbonator pump is locked off.	Unplug the unit and reconnect the unit. Main control board will reset, ice agitation will occur, and carbonator tank will refill to normal level.
	Note that this can occur while the water filter system is serviced or water supply is shutoff. If drinks are drawn from the dispenser while water pressure is shutoff, the carbonator pump starts and runs continuously, then shuts off on the 5 minute timeout.	1) low water pressure switch deactivates carbonator pump, 2) after 5 minutes reset and retry carbonator pump. If water supply is restored, the 5 minute timeout will not occur. Repeat reset a second time, but on a third time, then lockout carbonator pump, which will generate a service call.
Carbonated drinks are flat (low on carbonation)	CO ₂ is out	Replace CO ₂
	Carbonator tank is 100% filled because the city water pressure exceeds the carbonator tank CO ₂ pressure regulator setting.	CO ₂ setting for the carbonator tank is 75 psig, max water pressure is 60 psig. If necessary, install a water pressure regulating valve.
Low water pressure	Could be caused by excessively long runs (over 40 ft.) of 3/8" water supply line.	Increase line size to 1/2"
	Low water pressure	Add water pressure booster pump
	Plugged water filter.	Change water filter
	Water booster bladder has burst	Replace water booster tank/bladder



No Syrup or Watered down drink dispensed	Syrup supply is empty	Replace BIB
	BIB pump not working	Replace BIB pump
	No CO ₂ or compressed air supply to BIB pump, or not enough pressure	Check CO ₂ pressure regulator setting. 65 psig recommended. Replace CO ₂ tank or fix compressor.

Carbonator Troubleshooting

Symptom	Cause	Remedy
Carbonator pump does not start to fill tank	Power cord for the carbonator pump motor is not connected.	Carbonator pump is powered off the main control board inside the electrical box of the unit. Check that the umbilical cord is connected from the unit to the pump motor terminal box.
Power cord is connected but carbonator pump does not run.	Carbonator pump motor is disabled.	Check the enable/disable switch on the carbonator pump terminal box and enable it, if necessary.
	Probes were dry, unit was powered up, water was not turned on, and carbonator did not fill.	This results in a 5 minute timeout. Unplugging the unit and plugging it in will reset the unit and start the carbonator pump.
	Water service was interrupted for more than 5 minutes.	Unplugging the unit and plugging it in will reset the unit and start the carbonator pump.
Carbonator pump is short cycling with every drink drawn	Lower liquid level probe reads "dry" while upper probe reads "wet"	Check color of leads going to probes. Black should go to bottom probe and white to top probe. Reverse if incorrect.
Carbonator tank overfills, overflows through relief valve, and pump shuts off after 5 minutes.	A. Poor electrical connections between carbonator tank and main control board	A. Check connections at carbonator tank and at connector J4 on the main control board.
	B. Broken wires between carbonator tank and main control board	B. Replace wire harness
	C. Defective liquid level probes	C. Replace both liquid level probes

DIAGNOSTICS GUIDE FOR THE MAIN CONTROL BOARD

State	Observed State of Red LED	Sensor Input	Control Response	Service Remedy
0	Flash rate 3 seconds	Both probes read "wet"	Standby mode. Pump = OFF	No service required
1	Flash rate 1/2 second	Pump is OFF and HIGH probe reads "dry" and LOW probe reads "wet"	Waiting for level to drop below LOW probe. Pump = OFF	No service required
2	Flash rate 1/2 second	Both HIGH and LOW probes read "dry"	Normal mode. Pump = ON	No service required
3	Flash rate 1/2 second	Entered when HIGH probe does not detect liquid, and LOW probe does detect liquid, and pump is ON	Normal mode. Pump = ON	No service required
4	Flash rate 1 second	Entered when HIGH probe reads "wet" and LOW probe reads "dry"	THIS IS AN ERROR CONDITION.	<ul style="list-style-type: none"> - Check electrical connections at the carbonator tank, and at connector J4 on the main control board - Black wire should be connected to the LOW probe and also to Pin 4 of Connector J4 - Reverse the connections if incorrect - Replace harness if necessary
5	ON continuously, but "flickers" every 3 seconds	Poor signal connection to the carbonator tank. May result in short cycling of the carbonator pump.	Able to continue to function but carbonator pump short-cycles. Pump will come on each time a drink is drawn. THIS SITUATION SHOULD BE CORRECTED.	Check the harness connections of the red signal wire at both ends: <ol style="list-style-type: none"> 1) at the carbonator ring terminal and 2) at Pin 5 of the J4 connector at the main control board
6	ON continuously	Entered when pump has run continuously for 5 minutes	THIS IS AN ERROR CONDITION.	Unplug the unit and plug it back in. This will reset the unit's main control board and restart the carbonator pump.

DIAGNOSTICS GUIDE FOR FLAVORFUSION KEYPAD LIGHTING

Observations of LED Lighting on Customer Interface Keypad

	Symptom	Cause	Remedy
1	Bonus Flavor Icon and/or Drink Icon LEDs (see FIGURE 4) are ON continuously with four quick flashes every 30 seconds.	A. This indicates a poor connection in the lighting synchronization harness that connects the interface boards together.	A. Turn the keyswitch to disconnect power to the interface boards. Check the electrical connections between the harnesses that interconnect the right side of all interface boards together. Turn back the keyswitch to reconnect power.
2	Bonus Flavor Icon and/or Drink Icon LEDs (see FIGURE 4) are not in sync with the lighting sequence,	B. This may result over time as the lighting sequence between push button pads can become slightly out of synchronization.	B. Unplugging the unit and performing a power up will re-synchronize the lighting sequence.
3	Keypad LED lighting is not working	A. Poor connection between interface board and keypad PCB	A. Turn the keyswitch to disconnect power at the interface boards. Check harness connections at each interface board.
		B. Keypad LED's are burnt out	B. Turn the keyswitch to disconnect power at the interface boards. Unplug the ribbon cable from one interface board and test it by plugging it into the neighboring interface board. If the keypad still doesn't light up replace the keypad PCB.
		C. Interface board is defective.	C. Turn the keyswitch to disconnect power at the interface boards. Unplug the ribbon cable from one interface board and test it by plugging it into the neighboring interface board. If the LED's light up the interface board is defective. Replace the interface board.
		D. Corrosion at connector between keypad and ribbon cable.	D. Replace keypad circuit board and ribbon cable.
		E. Main control board is defective.	E. Replace the main control board.
4	During standby mode, the brand and bonus LED icons do not alternate back and forth - instead they light together.	Bonus buttons are incorrectly programmed as brand buttons, or vice versa.	Check the programming of each keypad and set each button as CW, PW, or timed dispense based upon the flavor lineup.

Contact your local syrup or beverage equipment distributor for additional information and troubleshooting of beverage system.