

**ASSISTANCE CENTER
AUTHORIZED DEALER**

**USE AND MAINTENANCE
INSTRUCTION MANUAL**

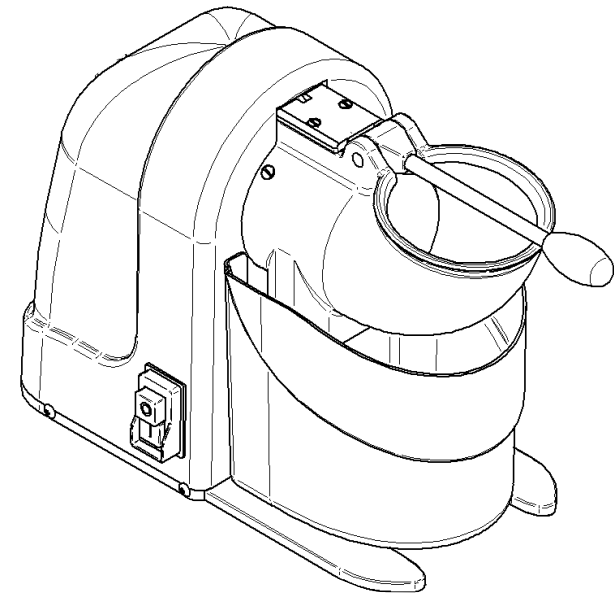

07/2008

ICE CRUSHER

INTRODUCTION

- This manual has been created to provide the **client** with all the information about the machine and the regulations regarding it, and also the use and maintenance instructions that enable using the machine in the most suitable way and maintaining its efficiency throughout time.
- This manual must be given to people who will use the machine and carry out periodic maintenance.

INDEX

CHAP. 1 - MACHINE INFORMATION	page 4
1.1 - GENERAL PRECAUTIONS	
1.2 - SAFETY DEVICES INSTALLED ON THE MACHINE	
1.2.1 - Electrical safety devices	
1.3 - DESCRIPTION OF THE MACHINE	
1.3.1 - General description	
1.3.2 - Constructive features	
1.3.3 - Machine makeup	
CHAP. 2 - TECHNICAL DATA	page 7
2.1 - OVERALL DIMENSIONS, WEIGHT, FEATURES . . .	
CHAP. 3 - RECEIVING THE MACHINE	page 8
3.1 - MACHINE SHIPMENT	
3.2 - CHECKING THE PACKAGE UPON ARRIVAL	
3.3 - DISPOSING OF THE PACKAGE	
CHAP. 4 - INSTALLATION	page 9
4.1 - PLACING THE MACHINE	
4.2 - SINGLE-PHASE ELECTRICAL CONNECTION	
4.3 - ELECTRICAL DIAGRAM	
4.3.1 - Single-phase electrical system diagram	
4.4 - OPERATIONAL CHECK	
CHAP. 5 - MACHINE USE	page 11
5.1 - CONTROLS	
5.2 - POSITION OF SAFETY MICROS ON ICE CHOPPER	
5.3 - LOADING THE PRODUCT	
5.4 - ADJUSTING THE BLADE THICKNESS	

8.2 - WEEE Waste of Electric and Electronic Equipment



Directive 2002/95/EC, 2002/96/EC and 2003/108/EC on the restriction of the use of certain hazardous substances in electrical and electronic equipment, and waste electrical and electronic equipment .

This symbol, crossed out wheeled bin, on the product or on its packaging indicates that this product must not be disposed of with your other household waste.

Separate waste collection of this appliance is organised and managed by the manufacturer. It is the user's responsibility to contact the manufacturer and follow the waste treatment system the manufacturer has adopted for separate waste collection.

The separate collection and recycling of your waste equipment at the time of disposal will help to conserve natural resources and ensure that it is recycled in a manner that protects human health and the environment.

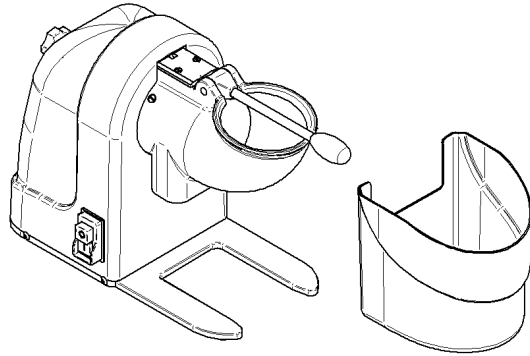

Fig. n°9 - Extractable parts for cleaning

CHAP. 6 - CLEANING AND DRYING

page 13

- 6.1 - GENERALITIES
- 6.2 - CLEANING PROCEDURES FOR THE MACHINE

CHAP. 7 - MAINTENANCE

page 14

- 7.1 - GENERALITIES
- 7.2 - FEEDING CABLE
- 7.3 - BLADE

CHAP. 8 - DISMANTLING

page 14

- 8.1 - PUTTING OUT OF COMMISSION
- 8.2 - WEEE Waste of Electric and Electronic Equipment

CHAP. 7 - MAINTENANCE

7.1 - GENERALITIES

Before doing any maintenance it is necessary to:

Disconnect the plug to completely isolate the machine from the rest of the system.

7.2 - FEEDING CABLE

Periodically check the state of wear and tear of the cable and call the "ASSISTANCE CENTER" if it needs to be replaced.

7.3 - BLADE

Periodically check the state of the blade, contact the "ASSISTANCE CENTER" if it needs to be replaced.

CHAP. 8 - DISMANTLING

8.1 - PUTTING OUT OF COMMISSION

If for some reason you decide to put the machine out of commission make sure that it cannot be used by anyone: **remove the blade, disconnect it and cut the electrical connections.**

CHAP. 1 - MACHINE INFORMATION

1.1- GENERAL PRECAUTIONS

- The machine must only be used by trained personnel who thoroughly understand the safety regulations contained in this manual.
- If personnel must be alternated provide training ahead of time.
- Before carrying out any cleaning or maintenance operation disconnect the machine plug from the electrical outlet.
- Carefully evaluate residual risks when intervening for maintenance or cleaning (therefore having to remove safety devices).
- Always concentrate while carrying out maintenance or cleaning operations.
- Regularly check the condition of the feeding cable, a worn or split cable is extremely dangerous.
- If there seems to be something wrong with the machine or it does not function correctly, it is advisable to not use it and to not try to repair it directly but to contact the "Assistance Center".
- Use the machine only for chopping ice.
- Do not place hands or other objects into the product inlet and outlet while the machine is running.
- Do not move the machine unless the switch is at "0" (off) and the plug is disconnected.
- The manufacturer cannot be held responsible in the following cases:
 - ⇒ the machine is mishandled by unauthorized personnel;
 - ⇒ machine parts are replaced with unoriginal ones;
 - ⇒ the instructions in this manual are not followed **carefully**; unsuitable products are used to treat the machine surfaces.

1.2 - SAFETY DEVICES INSTALLED ON THE MACHINE

1.2.1 - electrical safety devices (see Fig. n°7)

As far as electrical safety devices are concerned the machine described in this manual complies with the **CEE directives 2006/95, 2004/108** and the **CEE regulations EN 60335-1, EN 55014**.

The machine is outfitted with the following safety devices:

- magnetic safety micro on the collection basin;
- magnetic safety micro on the lever;
- mechanical safety micro on the back of the machine, which blocks running when the key to adjust blade thickness is inserted.

Even though the machine is outfitted with the regulatory measures for electrical and mechanical protections (both during operation and cleaning and maintenance procedures), there are in any case

5.4 - ADJUSTING THE BLADE THICKNESS

the following is the procedure for adjusting the thickness of the blade:

1. put the switch at "0";
2. disconnect the feed cable to completely isolate the machine from the rest of the system;
3. insert the key in the hole located on the backside of the ice chopper (see Fig. n°7) and turn the key in a clockwise or counter-clockwise direction, checking the variation in the blade thickness from the inlet with the lever lifted.
4. once the desired thickness has been set, remove the key from the hole and connect the plug to start using the ice chopper.

CHAP. 6 - CLEANING AND DRYING

6.1 - GENERALITIES

- The machine does not require particular cleaning.
- The machine must be dried at the end of every work cycle.
- All the parts of the machine must be carefully cleaned by using only a sponge or absorbent cloth.
- The machine must never be cleaned with water cleaners or jets of water, but with water and neutral detergents. Never use utensils, brushes or other that could damage the surface of the machine.

ATTENTION!

Before carrying out any cleaning operation it is necessary to:

- a) put the switch at "0"
- b) disconnect the plug to completely isolate the machine from the rest of the system.

6.2 - CLEANING PROCEDURES FOR THE MACHINE

N.B.: Never wash any part of the ice chopper in the dishwashing machine.

Before starting to clean the ice chopper extract the container from its place to be able to clean it entirely.

The casing of the machine and the inlet/outlet can be cleaned with a neutral detergent and a damp cloth, rinsing it frequently with warm water.

ATTENTION: once all the parts of the ice chopper have been cleaned, dry them well and reposition the container in its housing and lower the lever.

ATTENTION!

5.3 - LOADING THE PRODUCT

The ice to be chopped is loaded in the inlet only when the machine motor has stopped.

N.B.: The quantity of ice to be inserted must not overflow from the inlet, otherwise the magnet micro on the lever will not be able to make contact and the machine will not turn on.

Follow this procedure:

1. make sure the container is in the right position, so that it makes contact with the micro;
2. lift the lever so that it opens the inlet cover;
3. insert the right quantity of ice, the cover must be able to close;
4. start the machine by using the switch, pressing the "I" button;
5. exert light pressure on the lever until the ice passes completely in the blade;
6. assume a correct position to avoid accidents (see FIG. n°9): your body must be perpendicular with the work plane. **Never lean on the machine and avoid positions that bring your body in direct contact with the machine, use the lever.**
7. when work is complete stop the machine by pressing the stop "0" button;
8. avoid making the ice chopper run when empty;
9. carefully remove the collection container;
10. once the ice has been emptied from the container, reposition it immediately under the outlet because the ice remaining inside the opening melts with time and dripping on the plane could create risks;
11. **Never move the machine if the switch is not off ("0") and the plug disconnected.**
12. **If the chopped ice does not have the desired consistency use the key (equipped with the machine) to regulate the thickness of the blade to chop the ice more or less thickly.**

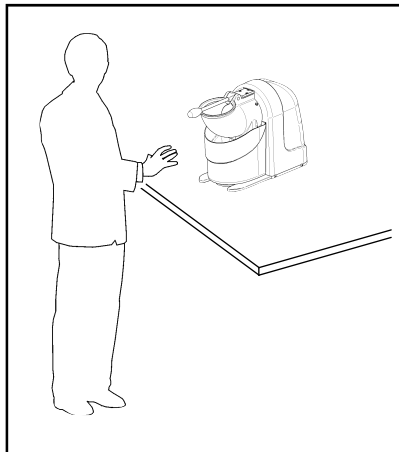

Fig. n°8 - Correct position

RESIDUAL RISKS, which cannot be completely eliminated and are referred to in this manual under **ATTENTION**.

1.3 - DESCRIPTION OF THE MACHINE

1.3.1 - general description

The ice chopper has been designed and manufactured by our company for the precise purpose of chopping ice, furthermore it guarantees:

- maximum safety during use, maintenance and cleaning;
- maximum hygiene due to a meticulous selection of materials that come into contact with foodstuff and the elimination of rough edges from the parts of the machine that come into contact with the product, in such a way to enable easy and thorough cleaning plus easy disassembly;
- all parts are robust and stable;
- easy handling.

1.3.2 - constructive features

- Casing and basin made of PS thermoformed polystyrene for food products;
- Body made of galvanized iron;
- Inlet/outlet and lever made of polished aluminum (UNI 6253 piral);
- Base made of polished aluminum (UNI 5083);
- Blade made of AISI 420 steel, nickel-plated and hardened;
- Rubber feet and stainless steel screws.

1.3.3 - machine makeup

Fig. n°1- General view of the machine

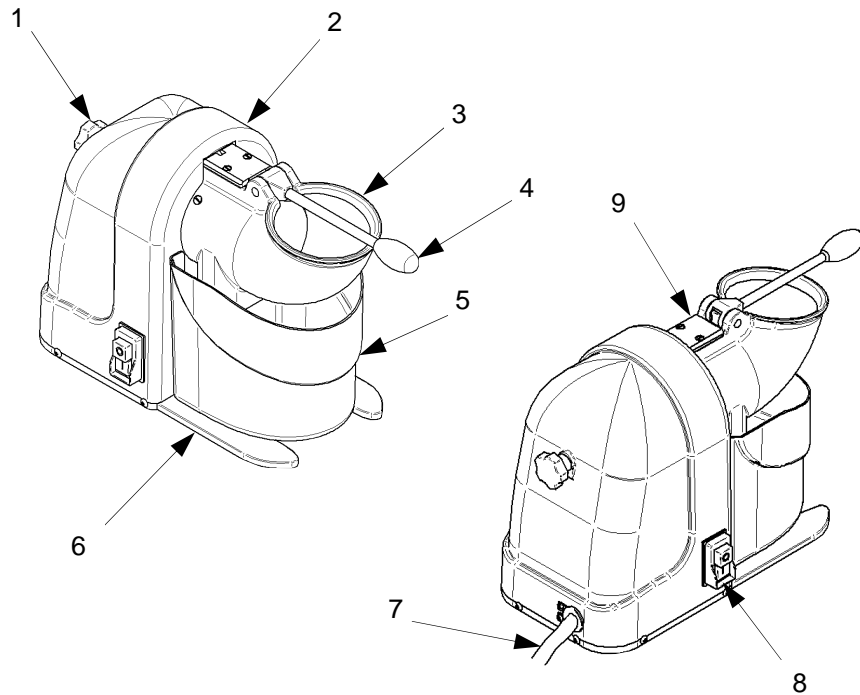

LEGEND:

1. Blade adjustment key
2. Casing
3. Inlet/outlet
4. Press lever
5. Container for worked product
6. Base
7. Feeding cable
8. On/Off switch
9. Magnetic micro lever support

CHAP. 5 - MACHINE USE

5.1 - CONTROLS

The controls are located on the machine casing as shown in the following diagram.

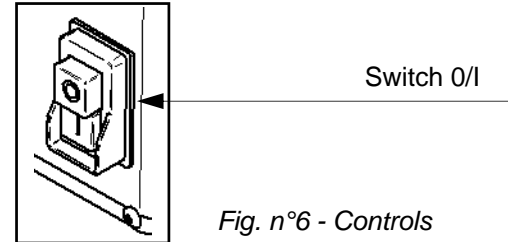

Fig. n°6 - Controls

5.2 - POSITION OF SAFETY MICROS ON THE ICE CHOPPER

- a) Magnetic micro: it blocks the ice chopper from running if the magnet of the basin does not react with the micros inside the machine (they must be aligned).
- b) Mechanical micro: it blocks the machine when the key is inserted to adjust the blade.
- c) Magnetic micro on the lever: it blocks the ice chopper from running when the lever has been lifted.

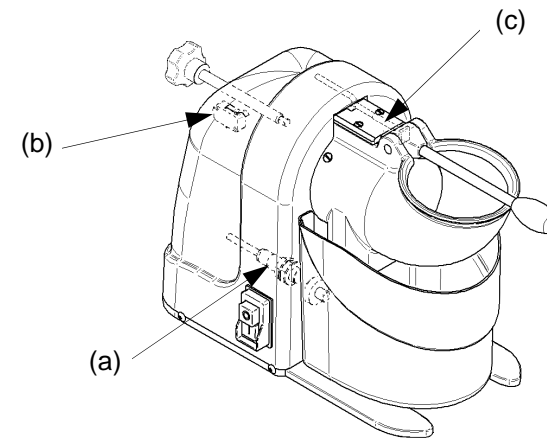

Fig. n°7 - Positions of safety micros

4.3 - ELECTRICAL DIAGRAM

4.3.1 - Single-phase electrical system diagram

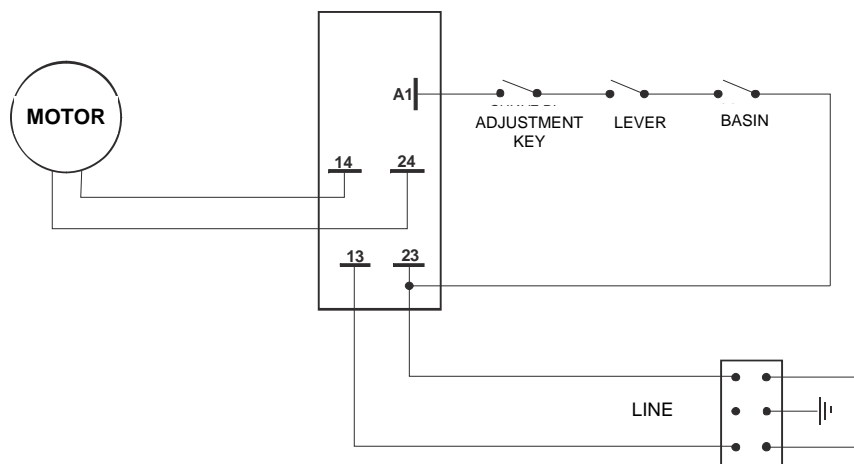

Fig. n°5 - electrical diagram

4.4 - OPERATIONAL CHECK

N.B.: Before testing the machine make sure that (see Fig. n°7):

- the collection basin is in the right position, that is when the micro is aligned with the magnet (ref. A);
- the key is not inserted in the machine (ref. B);
- the lever has been lowered enough to react with the magnetic micro (ref. C).

Then try running the machine using the following procedure:

- press the switch into the "I" position;
- check if the machine stops running by removing the container;
- check if the machine stops running by lifting the lever;
- at the end put the switch at "0" in the off position.
- Check if the machine does not start with the key inserted (ref. B) and keeping your hands off the machine (Fig. n°7).

CHAP. 2 - TECHNICAL DATA

2.1 - OVERALL DIMENSIONS, WEIGHT, FEATURES ...

Fig. n°2- Drawings of overall dimensions

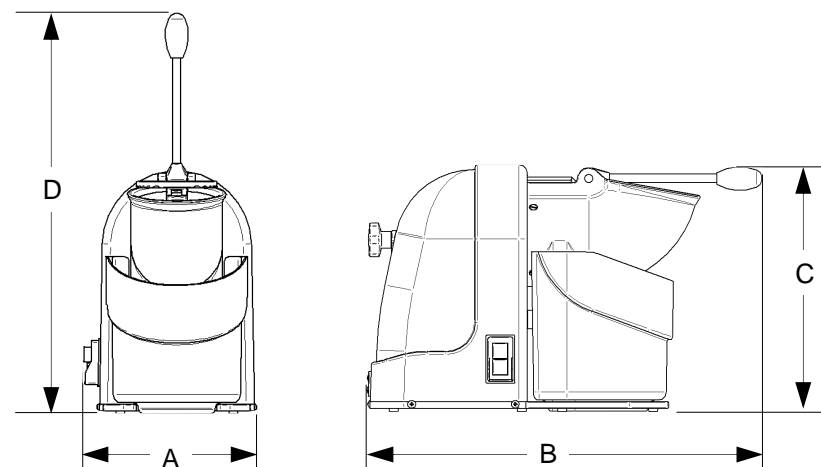

TABLE n°1- OVERALL DIMENSIONS AND TECHNICAL FEATURES

Model		Ice crusher
Length B	mm	465
Width A	mm	210
Height C	mm	295
Max. height D	mm	480
Power	watt/Hp	350
Power source		230/50Hz
Revolutions/ min.	r.p.m.	1.500
Net weight	kg	8,4

ATTENTION: The electrical characteristics of the machine are indicated on a plate on the back of the machine; before connecting the machine see **4.2 electrical connections.**

CHAP. 3 - RECEIVING THE MACHINE

3.1 - MACHINE SHIPMENT (see Fig. n°3)

The machine leaves our warehouses carefully packaged; the package consists of:

- External box in robust cardboard with padding if necessary;
- the machine;
- this manual;
- CE compliance certificate;
- Blade adjustment key.

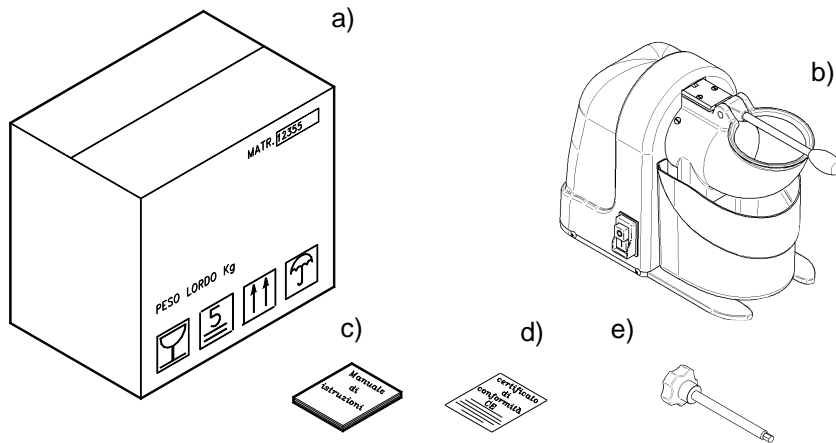

Fig. n°3 - Description of the package

3.2 - CHECKING THE PACKAGE UPON ARRIVAL

If the package does not show any external damage upon arrival, proceed to opening it and check if all the material is inside (see Fig. n°3). On the other hand, if the package shows signs of mishandling, bumps or falls, the carrier must be informed of the damage within three days of the delivery date, indicated on the documents, and write a precise report of the eventual damage done to the machine. **Do not turn the package over!!** When moving the machine make sure that it is firmly held in the four main points (keeping it parallel to the floor).

3.3 - DISPOSING OF THE MACHINE

The parts of the package (cardboard, plastic straps) are considered solid urban trash; therefore they can be normally disposed of.

If the machine is installed in countries, which have particular laws, dispose of the packages according to the laws in force.

CHAP. 4 - INSTALLATION

4.1 - PLACING THE MACHINE

The plane on which the machine is placed must have the necessary dimensions indicated in Table 1 and must therefore be wide enough, level, dry, smooth, robust, and stable.

Furthermore the machine must be placed in an environment with the maximum humidity of 75%, salt-free and with a temperature between +5°C and +35°C; in any case in environments that do not make the machine malfunction.

4.2 - SINGLE-PHASE ELECTRICAL CONNECTION

The machine is provided with a feeding cable with a 3 x 0.75 mm² section, 1.5 m long and a "SHUKO" plug.

Connect the 230 Volt 50 Hz machine, interposing a magnetothermic-differential switch of 10 A, $\Delta I=0.03A$. At this point make sure that the grounding system is in perfect working order.

Furthermore check that the data shown on the technical-registration plate (Fig. n°4) correspond to the data on the delivery documents.

Mod.	_____	_____	_____	_____		
Matr.	_____	_____	_____	Watt.		
	_____	H.p.	_____	A.	_____	Hz.
○	_____	~	Volts.	_____	Kg.	○
Anno	_____	_____	_____	_____		

Fig. n°4 - technical-registration plate