

REFRIGERATED MEAT MINCER

**TC 22 ICE
TC 32 ICE**

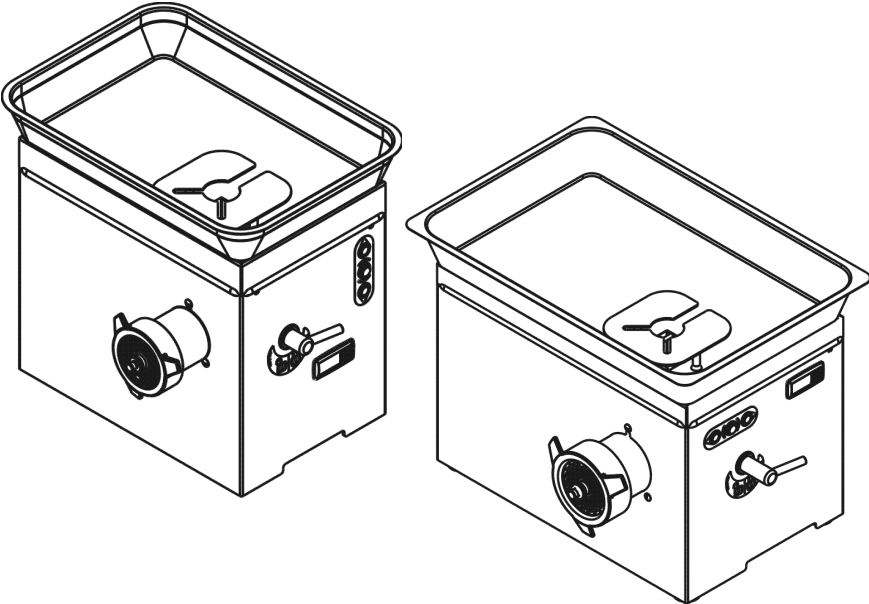

English

INSTRUCTION MANUAL FOR USE AND MAINTENANCE

CONTENTS

1. Delivery and warranty	5
1.1 Introduction	
1.2 Conservation and use of this manual	
1.3 Warranty	
1.4 Description of the machine	
1.5 Intended use	
1.6 Prohibited uses	
1.7 Identifying data	
1.7.1 Warning signs and danger	
1.8 Protections and safety devices	
1.8.1 Lock handle for meat output feed	
1.8.2 Protections of meat grinder plates with holes greater than to 8 mm	
1.9 Work position	
2. Specifications	10
2.1 Main parts	
2.2 Specifications	
2.3 Size and weight of the machine.	
3. Controls and Indicators	11
3.1 List of controls and indicators	
4. Thermostat	12
4.1 Technical features	
4.2 Display	
4.3 Alarms and signaling	
5. Testing, transport, delivery and installation	13
5.1 Testing	
5.2 Delivery and handling of machine	
5.3 Installation	
5.3.1 Disposal of packaging	
5.3.2 Handling the machine	
5.4 Connection to the electric mains	
5.4.1 Three-phase machine	
5.4.2 Single-phase machine	
6. Starting and stopping	15
6.1 Check for correct electrical connection	
6.2 Check for the presence and effectiveness of guards and safeties	
6.3 Check for efficiency of the stop button	
6.4 Starting the machine	
6.5 Stopping the machine	

7. Using the machine	15
7.1 Requirements	
7.2 Preparation of the output feed	
7.3 Using the meat grinder	
7.4 Dismantling and cleaning the mouth after use	
7.5 Assembling the mouth after cleaning	
7.6 Manual hamburger forming accessory	
7.6.1 Assembling the hamburger forming accessory	
7.6.2 Using the hamburger forming accessory	
7.6.3 Detaching the hamburger forming accessory from the meat grinder	
8. Maintenance	19
8.1 Requirements	
8.2 Lubrication	
8.3 Cleaning the machine	
8.3.1 Cleaning and maintenance of the controls	
8.4 WEEE Waste Electrical and Electronic Equipment	
9. Troubleshooting	20
9.1 Faults, causes and remedies.	
10. Wiring diagrams	21
10.1 230V 50 Hz 1ph	
10.2 400V 50 Hz 3ph	

1 - Delivery and Warranty

1.1 - Introduction

WARNING! The symbols used in this manual are intended to draw the reader's attention to issues and operations hazardous to the personal safety of the operators, or where there is risk of damage to the machine itself.

Do not operate the machine if you are not sure that you correctly understand what has been shown in these notes.

WARNING! Some of the illustrations in this manual, for reasons of clarity, show the machine or parts of it with the panels or guard removed.

Do not use the machine in such conditions, only use if provided with every protection properly fitted and working perfectly.

The manufacturer prohibits the reproduction, even partial, of this manual, and its contents cannot be used for purposes not permitted by the same. Violators will be prosecuted according to law.

1.2 - Conservation and use of this manual

The purpose of this manual is to inform users about the machine using text and figures to clarify the requirements and criteria essential for the transport, handling, use and maintenance of the machine. Thus, before using the machine read this manual carefully. Keep it safe near the machine, in a place easily and quickly accessible for future reference. If the manual is lost or damaged, obtain a copy from your dealer or directly from the manufacturer. In case of selling the machine, inform the manufacturer of the details and contact information of the new owner. The manual reflects the state of the art at the moment of its sale of the machine and cannot be considered unsuitable if, subsequent to new experiments, it were to be further upgraded. In this regard, the manufacturer reserves the right to update products and manuals without having to upgrade the product and previous manual, except in exceptional cases. If in doubt consult your nearest service centre or the manufacturer directly. The manufacturer is striving for the continuous improvement of its product. For this reason, the manufacturer is pleased to receive any suggestion or proposal intended to improve the machine and/ or manual. The machine was delivered with the warranty conditions applicable at the time of purchase. For assistance, contact your supplier.

1.3 - Warranty

The user is not allowed to tamper with the machine for any reason. For each problem encountered, contact the manufacturer.

Every attempt to disassemble, modify or generally tamper with any component of the machine by the user or by unauthorized personnel will result in the revocation of the **Declaration of Conformity** prepared in accordance with EEC directives 2006/42, and will void the warranty and release the Manufacturer from liability for damage resulting from such tampering.

The manufacturer also is released from any responsibility in the following cases: incorrect installation;

- misuse of the machine by personnel not properly trained;
- use contrary to the regulations of the country of use;
- lack of or unskilful maintenance;
- use of spare parts, not original and not specific for the model;
- total or partial failure to comply with the instructions.

1.4 - Description of the machine

The meat grinder in your possession is a simple, compact, highly efficiency and powerful machine.

- As it is supposed to be used for chopping food, the components that can come in contact with the product have been carefully chosen to ensure maximum hygiene. The housing is made of stainless steel AISI 304.
- The hopper is made of stainless steel AISI 304 to ensure maximum hygiene and easy cleaning.
- The plates and knives are made of grade AISI 430 stainless steel; therefore, they may rust if they are left immersed or wet. We recommend drying them after they are washed.
- Feed and rotor of cast stainless steel AISI 304 with the possibility of applying the UNGER system in whole or part.
- Possibility of reversing the direction of rotation using a switch.
- Rigid locking of the feed to improve the cut of the meat and extend the life of the plates and blades.
- Ventilated motors either three-phase or single phase with the following advantages:
 - consistency of performance and durability of the engine;
 - increase in the effective operating time due to fewer interruptions;
 - low rate of heat to keep the meat fresh and unaffected.

The models shown in this manual have been produced according to **EEC Directive 2006/42**, as amended.

In case of accident, no liability can be assigned to the manufacturer if the machine has been modified, tampered with, deprived of safety guards or used for purposes not intended by the manufacturer.

1.5 - Intended Use

The machine is designed and manufactured to grind meat or fish up to a maximum temperature of 7°C. After every work cycle, we recommend not leaving any food inside the grinding inlet or on the trays for long periods (maximum 5 minutes).

The meat grinder must be used in professional environments by qualified operators who have read and understood this manual.

Use the machine only when safely supported on a solid work table. The size of the meat to be ground must be such as to fit completely in the inlet feed and not overflow the hopper.

1.6 - Prohibited uses

The machine must only be used for the purposes intended by the manufacturer, in particular:

- **do not** use the machine for chopping foods other than meat and the like.
- **do not** use the machine if not properly installed with all the guards intact and properly installed to avoid the risk of severe injury.
- **do not** use nor store the machine inside a cold room: this could seriously damage the electrical components sensitive to condensate (which forms at low temperatures) and also alter the viscosity of the grease and/or lubricating oil in the gearbox housed inside it, jeopardising the machine's correct operation and causing potential failures.
- **do not** access the electrical components without first disconnecting the machine from the mains supply: **risk of electric shock** .
- **do not** process products that are larger than what can be totally contained in the loading hopper.

- **do not** wear garments that do not comply with safety regulations. Consult your employer about the requirements of safety in effect and the protective devices to be used.
- **do not** start the machine during a breakdown.
- Before using the machine, make sure that any unsafe condition has been properly removed. In case of any irregularities, stop the machine and warn those responsible for maintenance.
- **do not** allow unauthorized personnel to service the machinery.
- The first aid emergency treatment in case of accident caused by electric current is to remove the person from the conductor (as he has usually passed out).
- This operation is dangerous.
- The victim in this case has become a conductor: touching him means being electrocuted.
- Therefore remove the contacts directly from the supply valve of the line, or if that is not possible, remove the victim using insulating materials (sticks of wood or PVC, fabric, leather, etc.). The patient should be immediately seen by medical staff and admitted to a hospital.

1.7 - Identifying Data

An exact description of the "Model", the "Serial number" and the "Year built" of the machine will facilitate rapid and effective responses by the our Support Service. It is recommended to indicate the equipment model and serial number whenever you contact the support service. Collect the data from the plate shown in Fig. 1.7.1. As a reminder, we suggest reporting the data in the machine you have, in the table below:

WARNING! Do not alter the data on the plate for any reason.

Meat grinder model
Serial number
Year built
Type.....

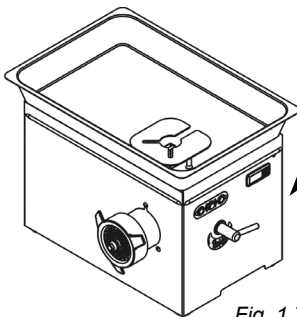





Fig. 1.7.1

MOD:	<u> A </u>	_____
VOLT:	<u> B </u>	WATT: <u> C </u>
HZ:	<u> D </u>	KG: <u> E </u>
AMPS:	<u> F </u>	ANNO: <u> G </u>
SERIAL NO:	_____	<u> H </u>
_____	<u> I </u>	
	<u> L </u>	

- A= model of the machine
- B = Power supply
- C = motor power
- D = motor frequency Hz
- E = Weight
- F = Amperage
- G = Year of manufacture
- H = Serial Number
- I = Manufacturer
- L = Bar code

1.7.1 - Warning signs and danger (fig. 1.7.2)

WARNING! With the machine connected to the electricity mains, do not work on the electrical components. There is a risk of electric shock. **Follow the instructions referred to on the plates. Failure to comply may cause injury.** Make sure the plates are present and readable. If not, apply or replace them.

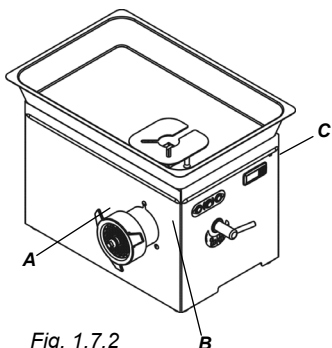

Fig. 1.7.2

A

CAUTION
IT IS PROHIBITED TO USE AN
OUTPUT MEAT PLATE WITH A
HOLE GREATER THAN 8 mm
WITHOUT ADEQUATE
PROTECTION

B

C

ATTENZIONE
è obbligatorio scollegare la spina di alimentazione prima di
rimuovere le coperture e accedere alle parti interne della macchina

WARNING
The plug must be disconnected from the electrical supply prior to
removing the covers and accessing the inside components
of the machine

1.8 - Protection and safety devices

WARNING! Before using the machine, check the correctness of the positioning of safety devices and their integrity.

Check their presence and efficiency at the beginning of each work shift. If it is not right, contact the maintenance manager.

1. Meat exit, plate holes of less than 8 mm.
In this case the fingers cannot enter the holes.
On request, it is possible to install plates with outlet holes larger than 8 mm.
In this case the user must provide a protection for this opening.
2. Stainless steel hopper rigidly set to the loading feed.
3. Protective casing for electrical components.
The bottom of the machine is closed by a guard, preventing accidental access to the electrical components inside.
4. Lock handle for the output feed for ground beef
- Turn the handle to allow the dismantling of the

feed and its related pieces (see sticker).

- Turn the handle to lock the outlet feed in operating position making sure it is set inside the housing provided (see sticker).

5. Protective hand guard.

The hopper, in the model, shows the guard "2" Fig.1.8.1 rigidly fixed, in accordance with the circular of the Ministry of Labour and Social Insurance No. 66 of 05.09.79. The smaller models do not require this guard due to the small size of the loading feed.

- 6 Pestle

- 7 Plexiglass feed tray lid

WARNING! Do not tamper with the safety devices for any reason.

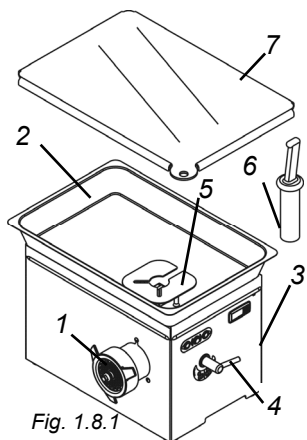

Fig. 1.8.1

1.8.1 Lock handle for meat output feed

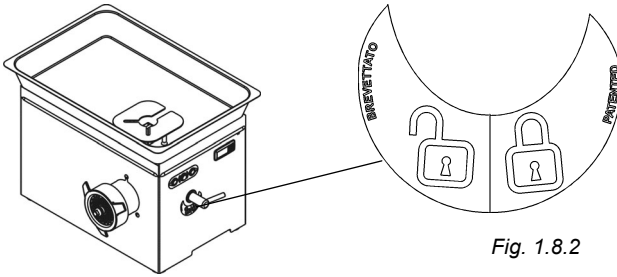

Fig. 1.8.2

Proper use:

If you want correct operation and precise grinding, all meat grinders need to have the feed tightly locked.

In order to avoid inaccurate fitting, it is important always to follow this installation process:

1. Make sure that the machine is switched off.
2. Insert the mouth, including the ring nut and internal components (worm, knives, plates) into the machine's mouth support.
3. Make sure that it is in the correct position, with the milled rear end of the worm perfectly slotted into the drive pin, then lock it with the tightening lever (ref. 4, see Fig. 1.8.1).

If it cannot be fastened:

- loosen the ring nut, without removing it
- push the mouth until it adheres to the machine body
- take the worm pin and turn it until the screw inserts perfectly into the drive pin
- fasten the mouth with the tightening lever
- take the plate tang and turn it until it inserts precisely into the guide pins on the mouth.
- tighten the ring nut fully

Standard on all models is a microswitch that is activated by the rotation of the handle:

- with the handle as shown in figure 1.8.3.1, the microswitch is shut off, the feed is free and the machine will not start;
- with the handle as shown in figure 1.8.3.2, the microswitch is turned on, the feed is locked and the machine works.



Fig. 1.8.3.1

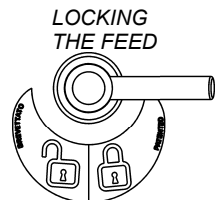
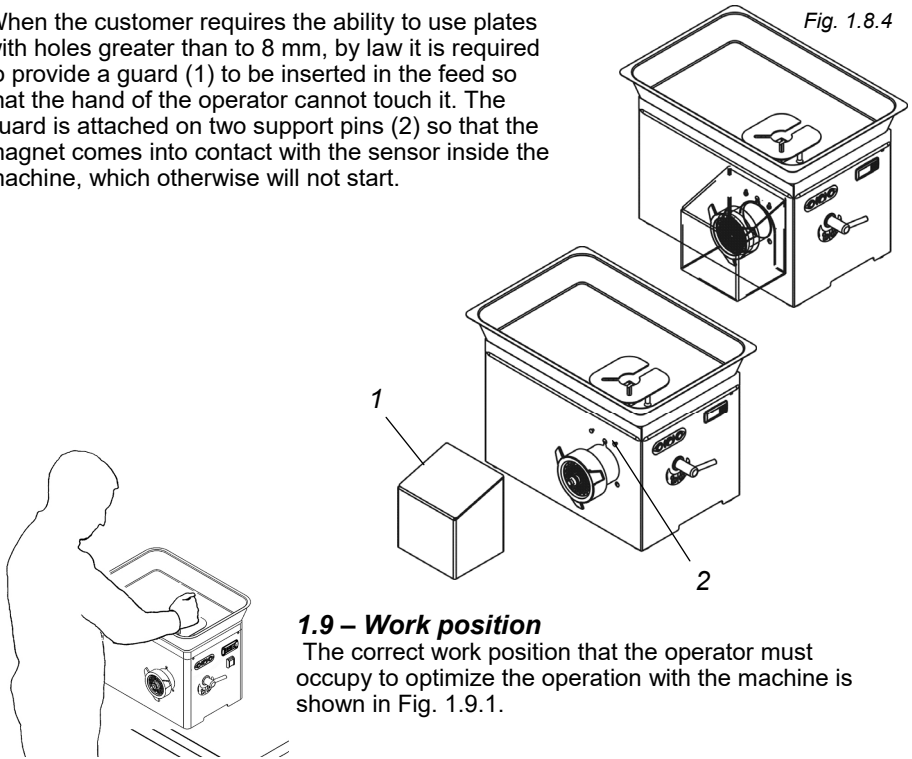

Fig. 1.8.3.2

1.8.2 - Protection of meat grinder plates with holes greater than to 8mm

When the customer requires the ability to use plates with holes greater than to 8 mm, by law it is required to provide a guard (1) to be inserted in the feed so that the hand of the operator cannot touch it. The guard is attached on two support pins (2) so that the magnet comes into contact with the sensor inside the machine, which otherwise will not start.



1.9 – Work position

The correct work position that the operator must occupy to optimize the operation with the machine is shown in Fig. 1.9.1.

2 - Specifications

2.1 - Main parts

To facilitate understanding of the manual the main components of the machine are listed below and shown in fig. 2.1.1.

1. Pestle is made of GUR HOSTALLOY 731
2. Feed release handle is made of stainless steel AISI 304
3. Machine controls
4. Feet
5. Output feed of ground meat is made of stainless steel AISI 304
6. Loading hopper is made of stainless steel AISI 304
7. Loading feed
8. Stainless steel AISI 304 housing.

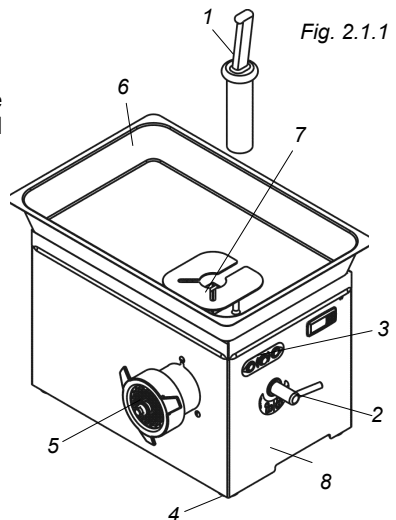

2.2 - Specifications

	Motor	Power	Output	Standard plates
	watt/hp		kg/h.	ø mm
TC 22 ICE	1472/2	230-400V/50Hz	300	4,5
TC 32 ICE	2208/3	230-400V/50Hz	500	4,5

2.3 - Size and weight of the machine

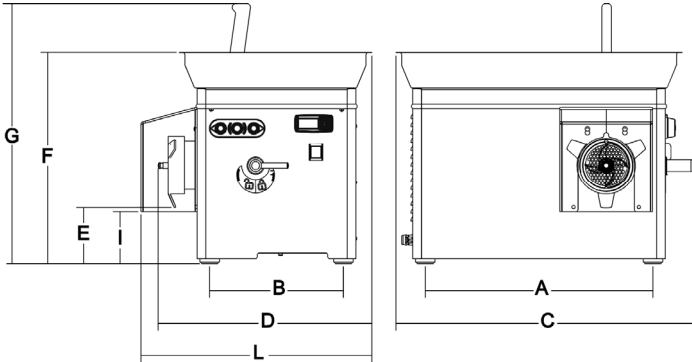

Fig. 2.3.1

	A	B	C	D	E	F	G	I	L	Net weight
	mm	mm	mm	mm	mm	mm	mm	mm	mm	Kg
TC 22 ICE	374	221	510	439	111	424	534	100	479	48
TC 32 ICE	485	285	635	495	120	451	555	110	542	60

3 - Controls and Indicators

3.1 - List of controls and indicators

Fig. 3.1.1

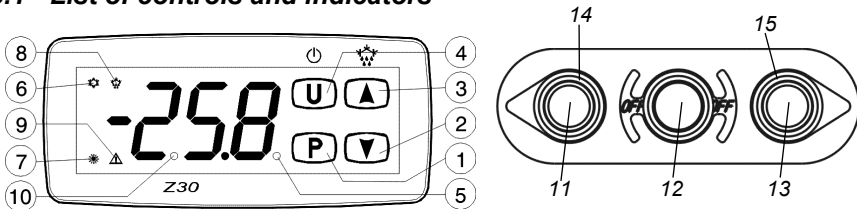

- Key P:** Used for setting the Set point (short press) and for programming the function parameters (pressed for 5 s). In programming mode is used to enter in parameters edit mode and confirm the values. In programming mode it can be used together with the UP key to change the programming level of the parameters. When the keyboard is locked it can be used together with the UP (hold pressed for 5 s) key to unlock the keyboard.
- Key DOWN:** In programming mode is used for decreasing the values to be set and for selecting the parameters.
- Key UP/DEFROST:** In normal mode can be used to start/stop manual defrosting (hold pressed for 5 s). In programming mode is used for increasing the values to be set and for selecting the parameters. In programming mode can be used together with key P to change parameters level. Pressed together

with the key P for 5 s allows the keyboard unlock.

- 4 - **Key U**: Used (short press) for displaying the instrument variables (measured temperatures etc.). In programming mode can be used to return in normal mode (hold for 2 s). It can also be programmed via the parameter "t.UF". In Normal mode and if "t.UF" = 4 it can be used to turning on and off (standby) the device (pressed for 1 s).
- 5 - **Led SET**: In normal mode shows when a key is pressed. In programming mode indicates the programming level of the parameters.
- 6 - **Led OUT - COOL**: Indicates the output status (compressor or temperature control device) when the instrument is programmed for cooling operation; on (on), off (off) or inhibited (flashing).
- 7 - **Led OUT - HEAT**: Indicates the output status (compressor or temperature control device) when the instrument is programmed for heating operation; on (on), off (off) or inhibited (flashing).
- 8 - **Led DEFROST**: Indicates defrosting in progress (on).
- 9 - **Led ALARM**: Indicates the alarm status (on), off (off) and silenced (flashing).
- 10 - **Led Stand-By**: Indicate the Stand-by status. When in Stand By mode is the only lighted LED.
- 11 - **Start push button (continuous)** Press to start the machine
- 12 - **Stop push button** Press to stop the machine
- 13 - **Gear inversion push button (discontinuous)** Enables inverting the propeller rotation direction
- 14 - **On led** It lights up when the machine is started
- 15 - **Return led** It turns on when the gear inversion push button is pressed

4 - Thermostat

4.1 - Technical features

Power supply: 115/230 ±10%;
AC Frequency: 50/60 Hz;
Power consumption: about 3 VA;
Inputs: 2 inputs for temperature probes:

NTC (103AT-2, 10 kW @ 25°C);
 PTC (KTY 81-121, 990 W @ 25°C);
 Pt1000 (1000 W @ 0°C);

1 free of voltage digital input as an alternative

to input 2;

Output: 1 relay output SPST-NO;

Relay output Electrical life: 100000 operazioni (secondo la EN60730);

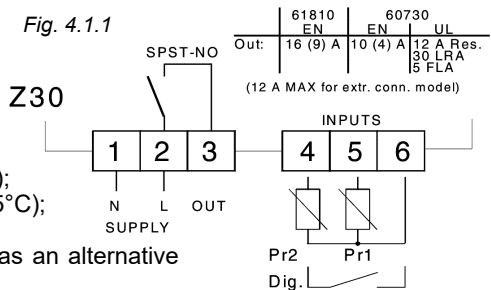

	EN 61810	EN 60730	UL 60730
Out - 16A - 1HP 250V, 1/2HP 125 VAC	16 (9) A	10 (4) A	12 A Res., 30 LRA, 5 FLA

Action type: Tipo 1.B (secondo la EN 60730-1);

Overvoltage category: II;

Protection class: Classe II;

Isolation: Reinforced insulation between the low voltage part and front panel;
Reinforced insulation between the low voltage section and the extra low voltage section (inputs).

4.2 - Display

During normal functioning the value observed by the environment probe or the second probe (parameter/4) is displayed. In case of alarm the temperature flashes alternately with the alarm code.

4.3 - Alarms and signaling

5 - Testing, transport, delivery and installation

Error	Reason	Action
E1 -E1	The probe may be interrupted (E) or in short circuit (-E) or may measure a value outside the range allowed	Check the probe connection with the instrument and check that the probe works correctly
EPr	Internal EEPROM memory error	Press P key
Err	Fatal memory error	Replace the instrument or ship to factory for repair

Additional reports:

Message	Reason
Od	Delay at power-on in progress
Ln	Keyboard locked
Hi	Maximum temperature alarm in progress
Lo	Minimum temperature alarm in progress
AL	Digital Input alarm in progress
oP	Door Open
dEF	Defrost in progress with "d.dL" = Lb
PdF	Post-defrosting in progress with "d.dL" = Lb
Eco	Eco Mode in progress

5.1 - Testing

The machine in your possession has been tested at our factory to ensure its smooth operation and proper adjustment. During this testing, tests were conducted in operation on material similar to that processed by the user.

5.2 - Delivery and handling of the machine

All the material shipped has been thoroughly checked before delivery to the carrier. Unless otherwise agreed with the customer, the machine is wrapped with nylon and strapped onto a pallet; the carton sheathes it from above which will also be strapped on the pallet. Upon receipt of the machine, verify the integrity of the packaging.

If the packaging is damaged, the carrier must sign the bill of receipt with a note such as " Accepted, with reservation ..." and reason.

After opening the package, if damaged machine parts are present, make a claim to

the carrier within three days of the date indicated on the documents.

5.3 - Installation

WARNING! The area where you plan to install the machine must be level, solid and on a flat shoring and must ensure its support in safety. The machine must also be placed so as to maintain ample space around it. This allows greater manoeuvrability in the work stages and ensures access for subsequent maintenance. Provide suitable lighting around the machine to ensure proper visibility to the operator using the machine.

- Remove the cellophane wrapping of the machine and any other packaging inside.

5.3.1 - Disposal of packaging

The packing materials such as cardboard, nylon, and wood products are comparable to municipal solid waste. They can then be disposed of freely. The nylon material is a pollutant that produces toxic fumes if burned. Do not burn and do not disperse but dispose of according to applicable laws. If the machine is delivered in countries where there are special rules, dispose of the packaging as required by the applicable legislation.

5.3.2 - Handling the machine

WARNING! Handle the machine with care and attention, avoiding accidental falls that could damage it severely. To avoid muscle strain in lifting the machine, lift using your legs.

5.4 - Connection to the electric mains

WARNING! Verify that the power supply line corresponds to the value on the nameplate of the machine. Any operation should be performed solely by qualified personnel expressly authorized by the manager in charge. Connect to a grid provided with efficient grounding plug.

5.4.1 - Three-phase machine

In these arrangements, the machine is supplied with a power cord of a section 4 x 1.5 mm.

This is connected to a three-phase three-pole + grounding plug. Connect the cable to the three-phase power supply by putting a 16 Amp circuit breaker switch.



5.4.2 - Single-phase machine

In this arrangement, the machine is supplied with a power cord of section 3 x 1.5 mm. This is connected to a single-phase three-polar plug. Connect the cable to the single phase power supply 220 Volt-50 Hz by inserting a 16 Amp circuit breaker switch.

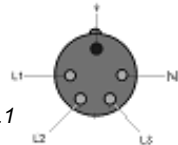

Fig. 5.4.1

In installations with voltages other than those mentioned above, please contact the manufacturer. If you need to lengthen the cord, use a cable of the same section as the one installed by the manufacturer.



N: solitamente o è di colore BLU oppure è indicato con il N° 4

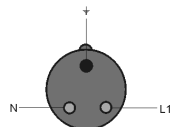

Fig. 5.4.2

6 - Starting and stopping

6.1 – Check for correct electrical connection

Plug into the electrical socket;

Press the button ("1" Figure 3.1.1), checking the direction of rotation of the utensils (in 380 three-phase version). The direction of rotation must be counterclockwise. If the rotation direction is backward, disconnect the machine from electricity and contact our dealer.

Note: For machines connected to a single-phase line and built at such a power, the correct direction of rotation is determined by the manufacturer.

6.2 – Check for the presence and effectiveness of guards and safeties

- 1 - **The outlet feed of the product.** Make sure that the outlet feed of the product has holes with a diameter of less than 8 mm. Otherwise, the guard must be installed on the feed.
- 2 - **Hand guard protection.** The hopper must have hand guard protection
- 3 - **Stainless steel hopper.** The stainless steel hopper is solidly attached to the loading feed.
- 4 - **Guard for protection of electrical components.** Check for the presence, integrity and the proper mounting of the guard for internal components of the machine.

6.3 - Check for efficiency of the stop button

With the machine connected to the grid and the utensils in motion, press the stop button "2" Fig. 5.3.1. The machine must stop.

6.4 - Starting the machine

To start the machine, just press the start button "1" Fig. 5.3.1, after having properly connected the plug to the electric mains supply and the machine is activated.

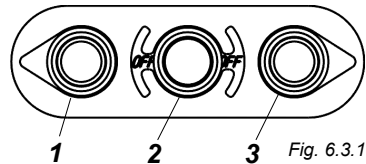

6.5 - Stopping the machine

To stop the machine, press the stop button, "2" Fig 5.3.1 and the machine stops

7 - Using the machine

7.1 - Requirements

WARNING! Only authorized personnel can service the machine.

Before starting use the operator is required to ensure that all the guards are in place and that the safety devices are in place and effective.

Otherwise, turn off the machine and contact the maintenance manager.

The product to be ground must be cut up to a size that can fit into the loading feed and must be pressed with the aid of the special pusher (pestle)

NEVER USE YOUR HANDS FOR THIS.

The machine is not designed to operate inside a cold room: this could seriously damage the electrical components sensitive to condensate (which forms at low temperatures) and also alter the viscosity of the grease and/or lubricating oil in the gearbox housed inside it, jeopardising the machine's correct operation and causing potential failures.

7.2 - Preparation of the output feed

The machine can be set to use three different meat cutting units:

A - Enterprise or normal

B - Partial UNGER

C - Total UNGER

- The system -C- (total UNGER), includes: a AISI 304 stainless steel rotor "1" to transport the meat, a AISI 430 steel fringer plate "2", a first knife "3" and the related perforated plate "4" both in AISI 430 steel, a second knife "5" with the final perforated plate "6" both in AISI 430 steel, a spacer "7" in AISI 304 stainless steel.

- The system -B- (partial UNGER), replaces the knife "5" and plate "4" with the spacer "7".

- The system -A- (Normal) is the easiest method of transport, composed only of the

AISI 304 stainless steel rotor, a knife and an output plate, both in AISI 430 steel. It is not possible to mount the plates of the B or C unit on models with A grinder; it is necessary to change the entire unit.

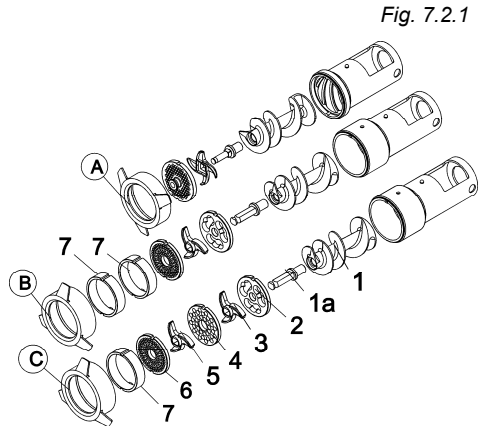

Fig. 7.2.1

7.3 - Using the grinder

1. Make sure that the supply voltage matches the value on the rating plate. The voltage indicator will be lit to indicate the connection to the electric grid.
2. Slightly tighten the ring nut of the meat grinder and put in some meat, press the start button, making sure that the direction of rotation is the same as that indicated by the arrow (counterclockwise).
3. If the meat output is cut well, the adjustment of the ring nut is fine, if not, tighten the ring nut more until you get a perfect cut of meat.
4. Stop the machine by pressing the stop button

7.4 - Dismantling and cleaning the mouth after use

- 1 Empty the mouth and inlet collar completely and then start the machine without any meat in it.
- 2 When you are sure that no processing residues are left in the collar and mouth, switch the machine off and disconnect it from the mains electricity.
- 3 Turn the mouth tightening lever to the release position (Fig. 1.8.3.1).
- 4 Detach the mouth completely and place it on a support surface.
You can now dismantle the components of the mouth.
- 5 Loosen the ring nut fully until it slides off.
- 6 Extract the plate and knives, followed by the worm.
- 7 Clean every component.

7.5 - Assembling the mouth after cleaning

After properly cleaning each component, reassemble the mouth.

1. Insert the mincing worm.
2. Insert the knife and plate, while making sure that the knife is mounted with the blade facing the mincing plate.
3. Screw on the ring nut and tighten it slightly.
4. Mount the machine mouth by following the instructions of Paragraph 1.8.1.

7.6 - Manual hamburger forming accessory

The meat grinder can be supplied with a manual hamburger forming accessory.

This accessory must be mentioned when ordering the machine, so that the latter can be fitted during its assembly with:

- 1: sensor that controls the start/stop of the meat grinder;
- 2: a sensor that detects the presence of the hamburger forming accessory, positioned inside the casing;
- 20: ring-nut mount;
- 21: plate without tang;
- 22: short worm pin.

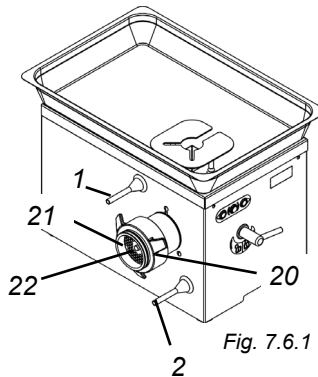

Fig. 7.6.1

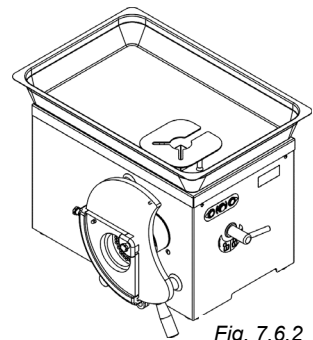

Fig. 7.6.2

7.6.1 - Assembling the hamburger forming accessory

The hamburger forming accessory is supplied with all its parts dismantled.

To assemble it correctly, proceed as explained below.

PHASE 1

- Loosen the knob (1)
- Loosen the knob (2)

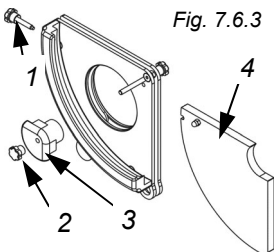

Fig. 7.6.3

- Remove the aluminium central pin (3)
- Remove the plexiglass slab (4) closing the hamburger forming accessory

PHASE 2

- Insert the PE500 polyethylene slider (9) inside the aluminium profile (11).
- The threaded pin (18) must slot through the hole (19) in the slider.

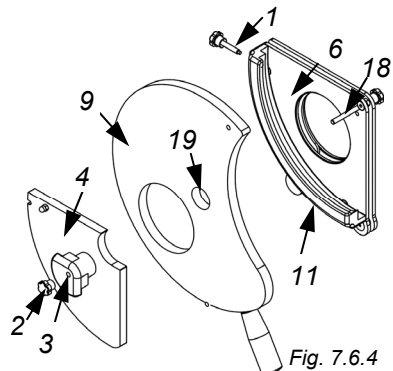

Fig. 7.6.4

- Insert the plexiglass slab (4) into the aluminium profile (11), positioning it above the slider (9).
- Attach the plexiglass slab (4) to the plate (6):
- insert the knob (1) through the slotted hole on the slab (4);

FASE 3

- tighten the knob (1) fully;
- insert the aluminium block (3) through the hole (19);
- fasten the aluminium block (3) to the plate (6), tightening the knob (2) to the threaded pin (18)

Adjusting the hamburger forming accessory on the meat grinder:

Attach the hamburger forming machine to the meat mincer, positioning it against the ring nut (20), through the hole on the rear plate (25).

Push it until the hamburger forming accessory presence sensor (2), located on the casing (25), slots through the hole on the plate (7);

Fig. 7.6.5

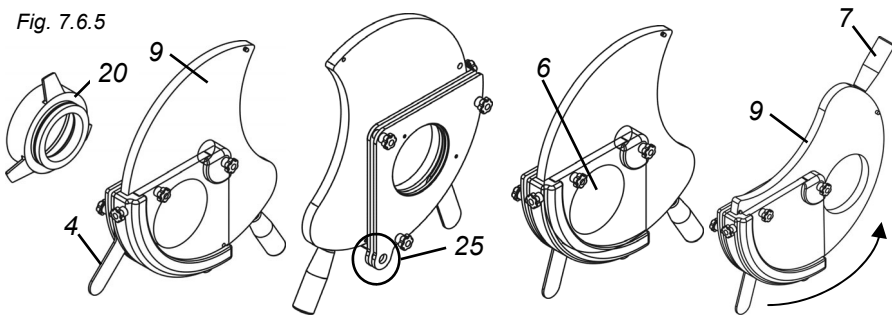

7.6.2 - Using the hamburger forming accessory

After installing it correctly and fastening it to the meat grinder, the hamburger forming accessory can be used.

WARNING! The operator must supervise the hamburger forming accessory while it operates and during the hamburger production process.

- load the product to be ground into the meat grinder's hopper
- start the meat grinder by pressing the start button
- the ground meat that comes out of the meat grinder's mouth fills the hamburger die
- visually inspect the process and remove the hamburger once it has been formed, by turning the hamburger forming accessory slider anti-clockwise, holding it from the knob
- only in this way will the machine stop working and pushing the ground meat outwards
- after removing the hamburger from inside the die, put the slider back into place by turning it clockwise, holding it from the knob
- this will cause the hamburger production cycle to resume

The sliders come with different dies for the hamburgers:

- S1 Chicken leg - approx. 105 g
- S2 Oval - approx. 130 g
- S3 Meat balls - approx. 20 (x4) g
- S4 Square - 100 x 100 mm - approx. 150 g
- S5 rectangular - 100 x 125 mm - approx. 190 g
- S6 Round - ø 110 mm - approx. 155 g
- S7 Round - ø 100 mm - approx. 140 g
- S8 Adjustable from round to oval - 100 g – 200 g

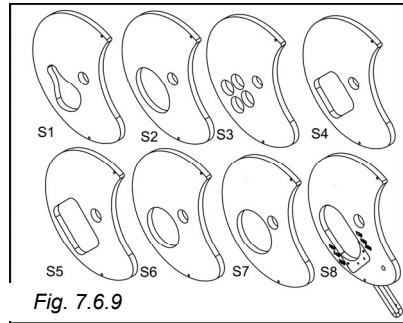

7.6.3 Detaching the hamburger forming accessory from the meat grinder

- with the meat grinder switched off, raise the fastening lever and unlock the hamburger forming accessory
- hold the hamburger forming accessory with both hands and push it towards you
- remove it from the ring nut and from the two pins at the base of the casing

8 - Maintenance

8.1 - Requirements

WARNING! All the maintenance and cleaning must be performed with the machine at a standstill, disconnected from the power mains. The area where maintenance operations are performed must always be kept clean and dry. Do not allow unauthorized personnel to service machinery.

Any replacement of parts, including replacement of the utensils must be made with original parts from authorised shops or directly from the manufacturer.

8.2 - Lubrication The machine does not require lubrication.

8.3 – Cleaning the Machine

WARNING! Unplug the machine from the mains before cleaning. Do not clean the machine with a water jet. Use only non-toxic cleaners, and specifically for the cleaning of components for use with food. Plates and knives are made of AISI 430 steel, if left wet or to soak, they can rust. It is advisable to dry them after washing. Clean the condenser regularly, at least once a month. Use a scrub brush (no metal) or a vacuum cleaner (suggested). Carefully remove dust and dirt between fins. Pay attention not to damage them. Please note that a long time dirty condenser means more power consumption and an overall bad performance of the cooled mincer.

8.3.1 - Cleaning and maintenance of the controls

The buttons fitted on this machine are of an extremely high quality standard and can be washed with water as they have a class IP67 protection rating. Should they get clogged or jammed after being touched with dirty hands, do not use knives or sharp tools to try to release them.

WARNING! Pull out the power plug before every cleaning operation, transfer the machine to an adequate location and spray the buttons with hot water (avoid high-pressure jets).

Be **CAREFUL** not to let any water penetrate into the other parts of the machine, for reasons of electrical safety and to preserve the machine's working life.

This operation should soften the grease and dirt, releasing the button.

Once the buttons have been released, press them several times (with the plug detached) in order to expel any remaining dirt inside them. If the operation fails from the beginning, repeat the washing operation several times until the buttons have flushed out all the dirt.

Alternatively, prevent use of the machine and contact the Service Centre to replace the buttons. Buttons that have been scratched or tampered with using blunt tools shall not be covered by the warranty.

8.4 WEEE Waste Electrical and Electronic Equipment



The symbol of the barred trash bin as shown on the equipment or on its packaging indicates that the product at the end of its life must be separated from other waste. The recycling of this equipment at the end of its life is organised and managed by the manufacturer. The user who wishes to dispose of this equipment shall contact the manufacturer and follow the system that has been adopted to allow the separate collection at the end of its life. Proper differentiated collection by subsequent sending of the equipment waste to recycling, treatment and environmentally compatible disposal helps to avoid possible negative environmental and health effects and promotes *the reuse and/ or recycling of materials making up the product*. **Illegal disposal of the product by the owner will lead to the application of administrative sanctions provided by law.**

9 - Problems and solutions

9.1 - Problems, causes and solutions

If the problem continues after the various checks call the nearest assistance center. **Attention:** In the case of gas leaks or fire do not go near the motor opening and remove electrical tension from the appliance. Do not use water to extinguish the flames but only dry extinguishers. All materials that make up the appliance are fire-retardant or self-extinguishing and are not combustible.

Problems	Causes	Solutions
The machine does not start	<ul style="list-style-type: none"> - The differential switch is on position "0". - The outlet switch is on position "0" - The push-button "on" does not work. - The electrical motor is faulty. - The safety devices are removed or not present. 	<ul style="list-style-type: none"> - Turn the switch to position "I" - Turn the switch to position "I" - Call the technical service centre - Call the technical service centre - Check safety devices
The screw propeller does not turn in the sense indicated by the arrow (on three-phases model)	Reverse phase wire on plug	Contact Technical Support
The product is not minced correctly	<ul style="list-style-type: none"> - The plate and the knife are not tightened correctly - There is some rust on the plate and knife, they do not stick perfectly to each other (on the surface of the plate) - The feed opening is not installed correctly - Loose ring nut 	<ul style="list-style-type: none"> - Tighten correctly the plates and knife - Replace the faulty plate and knife - Install correctly the feeding opening - Tighten the ring nut properly
Non fa freddo	<ul style="list-style-type: none"> - The condenser is not clean and not able to carry out its function of heat exchange. - The air intakes are not blocked - The appliance is not near air currents or heat sources 	<ul style="list-style-type: none"> - clean the condenser - move eventual blocking - move the machine

10 - Wiring diagrams

10.1 - 230V 50Hz 1ph

English

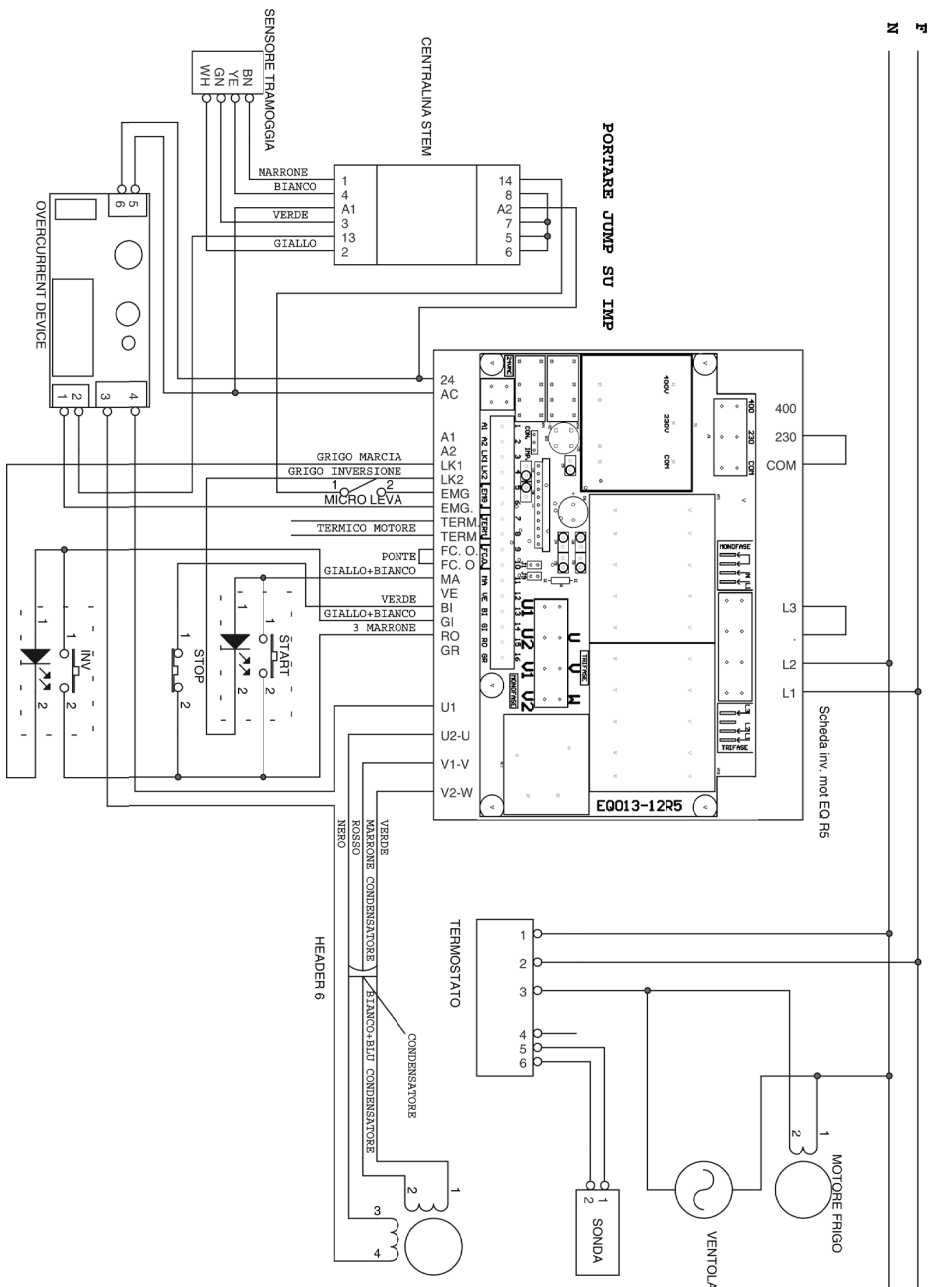

AUTHORISED DEALER CENTER