**Installation and Operations Manual
For
R290
ICE CREAM DIPPING-DISPLAY MERCHANDISERS**

DD-xx – Standard Models
DD-xxL – Low Glass Models
DD-xxLCG – Low Curved Glass Models

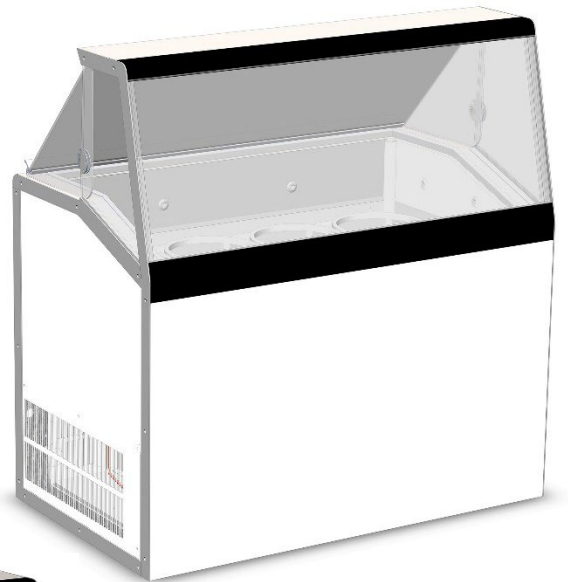
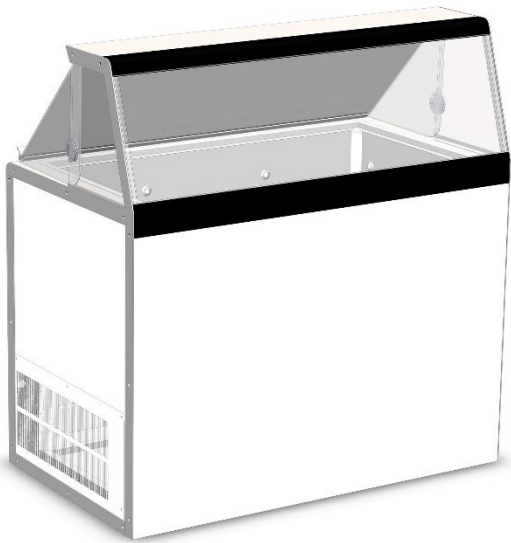

TABLE OF CONTENTS

INTRODUCTION	3
STORE CONDITIONS	3
WARNING LABELS AND SAFETY INSTRUCTIONS	4
PRE-INSTALLATION INSTRUCTIONS	5
Inspection for Shipping Damage	5
INSTALLATION INSTRUCTIONS	6
General Instructions	6
Electrical	6
Mechanical	7
Startup	7
TEMPERATURE CONTROL	8-9
CLEANING INSTRUCTIONS	10
Can Holder Cleaning	11
Frost Shield Cleaning	11
Lid Locking Kit	12
OPERATION CONDITIONS AND PRESSURES	13
SERVICE INSTRUCTIONS (Trouble Shooting Guide)	13
CONTROLLER SENSER PROBE LOCATION	14
AIR FILTER CLEANING INSTRUCTION	15
DIPPING-DISPLAY CABINET PART NUMBERS	16
OPTIONS	17
SALE AND DISPOSAL	17
WIRING DIAGRAMS	18-20

INTRODUCTION

This manual contains important instructions for installing, using and servicing the **Ice Cream Dipping-Display** case. A part list is included in this manual. Read all these documents carefully before installing or servicing your equipment.

CAUTION

This unit uses a flammable refrigerant. Use care when handling and operating to avoid damaging the refrigerant tubing or increasing the risk of a leak.

All service should be performed by factory authorized personnel. All component parts shall be replaced with like components to minimize the risk of possible ignition due to incorrect parts or improper service.

STORE CONDITIONS

The cases are designed to operate in the controlled environment of an air-conditioned store. The store temperature should be at or below 75°F and a relative humidity of 55% or less. At higher temperature or humidity conditions, the performance of these cases may be affected and the capacity diminished. It is not uncommon in a newly constructed store for the temperature and humidity to be above design conditions. These excessive conditions may produce sweating in the case until the store is operational and the ambient environment is more desirable.

These cases should not be positioned where it is directly exposed to rays of sun or near a direct source of radiant heat or airflow. This will adversely affect the case and will result in poor performance.



Read this manual before installing your cabinet. Keep the manual and refer to it before doing any service on the equipment. Failure to do so could result in personal injury or damage to the cabinet.



Improper or faulty hook-up of electrical components of the refrigeration units can result in severe injury or death.

NEVER use an extension cord to power this unit. All electrical wiring hook-ups must be done in accordance with all applicable local, regional or national standards.



Installation and service of the refrigeration and electrical components of the cabinet must be performed by a refrigeration mechanic and/or a licensed electrician

The portions of this manual covering refrigeration and electrical components contain technical instructions intended only for persons qualified to perform refrigeration and electrical work.

This manual cannot cover every installation, use or service situation. If you need additional information have the serial number at hand and call or write us:

Refrigerated Solutions Group
891 County Road U
Hudson, WI 54016
800-388-5253

WARNING LABELS AND SAFETY INSTRUCTIONS



This symbol is used to alert user that there is risk of fire or explosion since flammable refrigerant is used. This symbol can be observed on back or sides of cabinet.



This symbol is the safety-alert symbol. When you see this symbol on your cabinet or in this manual, be alert to the potential for personal injury or damage to your equipment.

Be sure you understand all safety messages and always follow recommended precautions and safe operating practices.



NOTICE TO EMPLOYERS

You must make sure that everyone who installs, uses or services your cabinet is thoroughly familiar with all safety information and procedures.

Important safety information is presented in this section and throughout this section and throughout the manual. The following signal words are used in the warnings and safety messages:

DANGER: Severe injury or death will occur if you ignore the message.

WARNING: Severe injury or death can occur if you ignore the message.

CAUTION: Minor injury or damage to your cabinet can occur if you ignore the message.

NOTICE: This is important installation, operation or service information. If you ignore the message, you may damage your cabinet.

The warning and safety labels shown throughout this manual are placed on your cabinet at the factory. Follow all warning label instructions. If any warning or safety labels become lost or damaged, call your customer service department at 800-388-5253 for replacements.

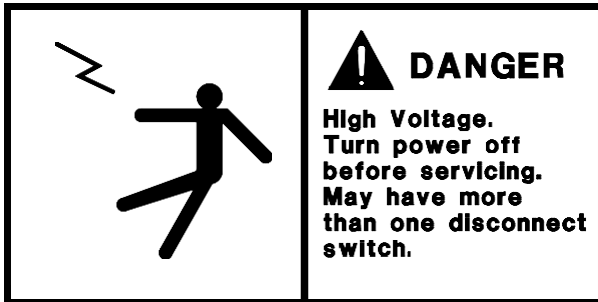

This label is located on top of the electrical control label and on the wiring channel.

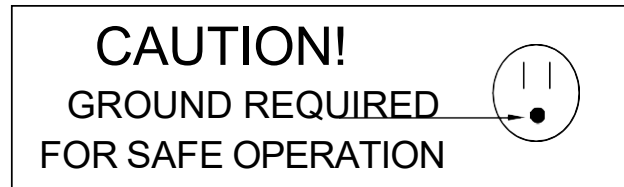

This label is attached to the cabinet power cord on models with a power cord.

PRE-INSTALLATION INSTRUCTIONS

INSPECTION FOR SHIPPING DAMAGE

You are responsible for filing all freight claims with the delivering truck line. Inspect all cartons and crates for damage as soon as they arrive. If damage is noted to shipping crates or cartons or if a shortage is found, note this on the bill of landing (all copies) prior to signing.

If damage is discovered when the cabinet is uncrated, immediately call the delivering truck line and follow up the call with a written report indicating concealed damage to your shipment. Ask for an immediate inspection of your concealed damage item. Crating material must be retained to show the inspector from the truck line.

INSTALLATION INSTRUCTIONS

GENERAL INSTRUCTIONS

1. Be sure the equipment is properly installed by competent service people.
2. Keep the equipment clean and sanitary so it will meet your local sanitation codes.
3. Rotate your stock so that older stock does not accumulate. This is especially important for ice cream. A "First-In, First-Out" rotation practice will keep the products in good salable condition.
4. Do not place product in the case when it is soft or partially thawed. Also, product should not be put in the case for at least 6 hours after it is started.
5. Stock cases as quickly as possible, exposing only small quantities to store temperatures for short periods of time.
6. When replacing burned out LED, be sure that the electrical power to the lighting circuit is turned off.

NOTICE TO STORE OWNERS / MANAGERS

Moisture or liquid around or under the cabinet is a potential slip/fall hazard for persons walking by or working in the general area of the cabinet. Any cabinet malfunction or housekeeping problem that creates a slip/fall hazard around or under the cabinet should be corrected immediately.

If moisture or liquid is observed around or under a cabinet, an immediate investigation should be made by qualified personnel to determine the source of the moisture or liquid. The investigation should determine if the cabinet is malfunctioning or if there is a drainpipe leaking.

ELECTRICAL



WARNING

Before servicing electrical components in the case, make sure all power to case is off. Always use a qualified technician.



NOTICE

For replacement ballast, use only ballast that complies with UL and recommended in part list.

MECHANICAL

Remove grille and check refrigeration lines to see that they are free (not touching each other or compressor). Spin condenser fan blade to see that it is free.

Check that all service valves are open. The picture below is standard DD series condensing unit. The compressor is hermetic, it is internally spring mounted and ready to run.

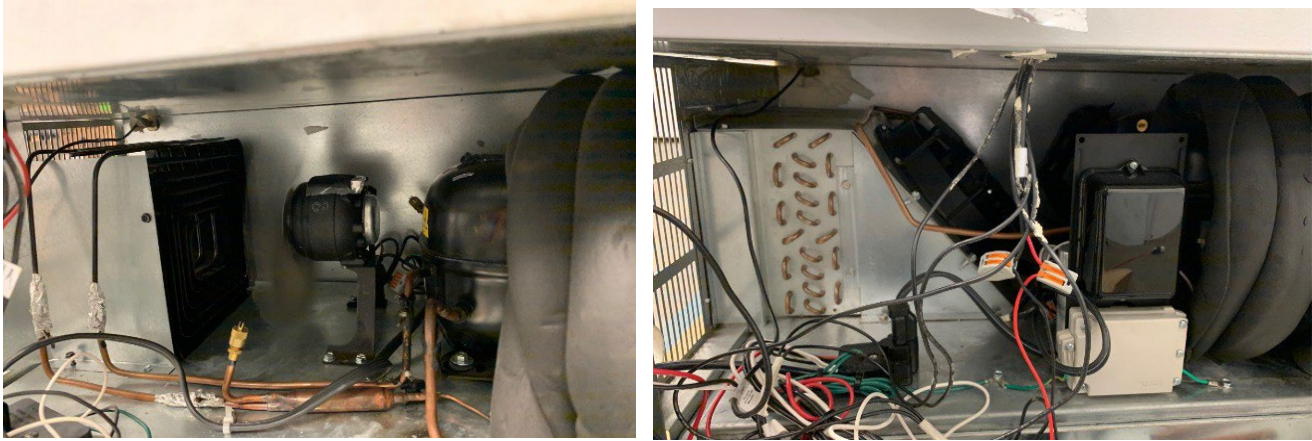

Hermetic Compressors, Jelly Roll & fin and tube condenser

Remove cabinet from crate base and slide into location. Cabinet must be level from side to side and front to back.

To comply with Sanitation requirements the cabinet must be mounted on legs (6" high min.) or casters or the base must be sealed to the floor with an N.S.F. listed silicone sealant.

STARTUP

Uncoil the lead cord and pass it through the hole provided in the grille. While the cabinet is in operation, check the voltage draw and the amperage draw versus this rating on the nameplate. Voltage should be checked at the compressor terminals while the compressor is initially starting. The unit is designed to operate at +/- 10% of 115 volts, 60 cycle, single phase. This means that the voltage should be between 103 and 126.5 volts.

After the cabinet has pulled down in temperature to approximately 0°F at load line, check the thermostatic control by turning it to its warmest position. This should shut the compressor off. A separate 20 amp. fuse circuit for each cabinet is recommended to avoid the possibility of other appliances on a circuit from overloading and causing a malfunction. Make sure that the electrical service is grounded upon installation.

TEMPERATURE CONTROL

The **dipping-display** cabinet has a temperature control that is adjustable from #1 (warmest setting) to #9 (coldest setting). Turn the control knob in line with the punch mark to the desired setting. The temperature control is located near the condensing unit at the front of the cabinet.

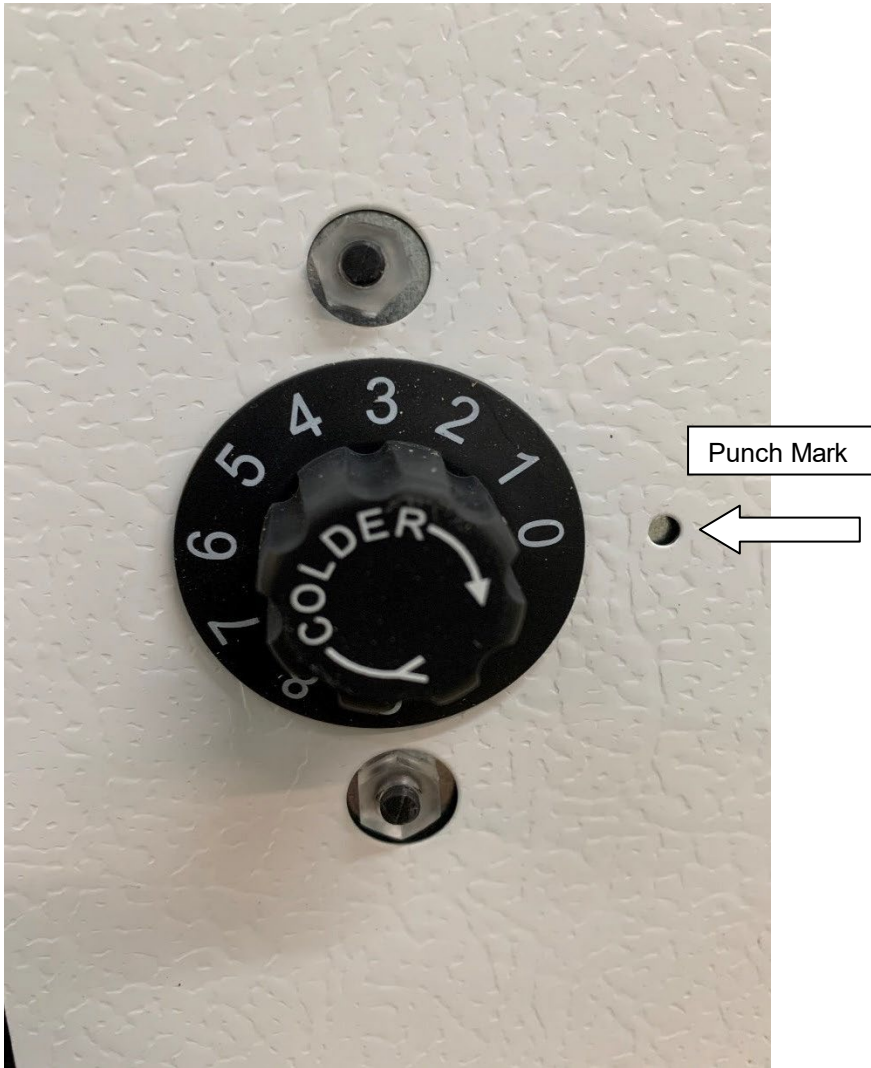

WARMEST SETTING

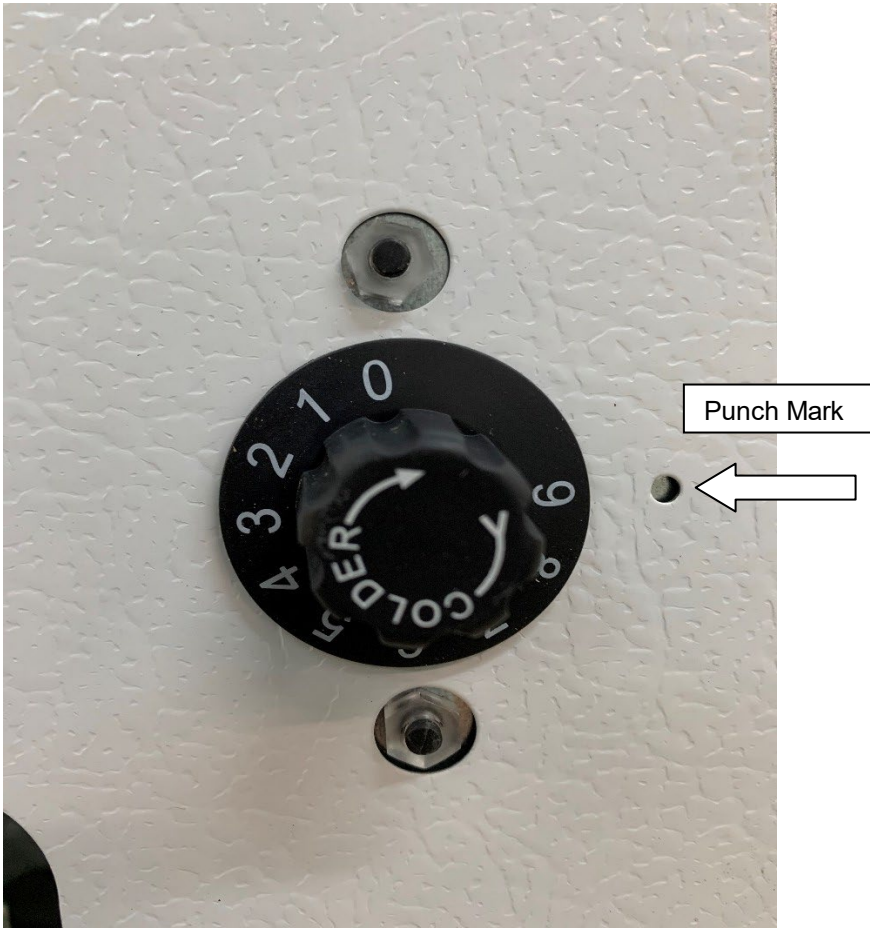

COLDEST SETTING

Can Holder Assembly Removal And Cleaning (Optional)

Remove plastic can clamp by screwing knob off the threaded shaft. Wash the can holder and can clamp with a non-abrasive detergent to maintain sanitary gloss. Remove the shaft by loosening the wing nut and unscrewing the shaft from the shelf. Wash the shaft and shelf using a non-metallic brush.

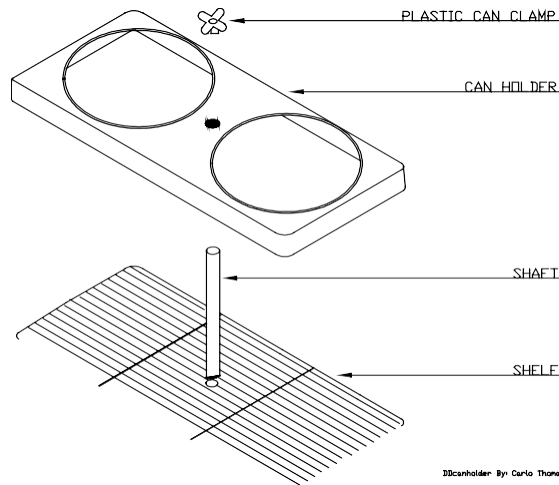

Frost Shield Removal and Cleaning (optional)

When the frost-shields accumulate approximately ½ to 1 inch of frost (about two to three days), remove it by lifting up to disengage from the keyhole slot. Remove the frost by holding under running water until clean. Dry and replace the frost-shield by engaging screws at the big end of the keyhole and push down.

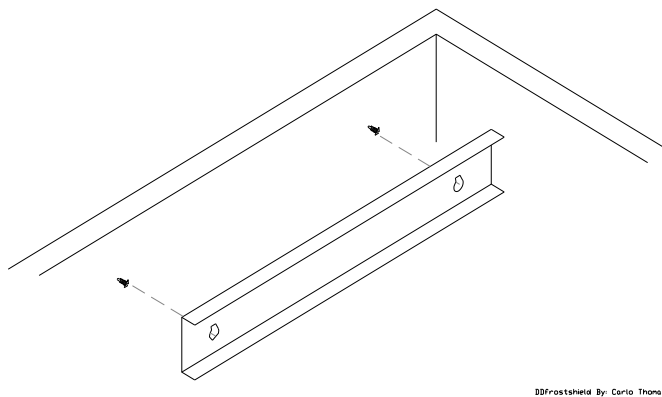

Lid Locking Kit Installation (Optional)

A simple and easy to install Lid locking kit option is available to restrict from unwanted access to the ice cream stored inside the dipping cabinets. When the option is opted, please follow the below instruction to lock the lid. One kit is needed for each Lid to be locked.

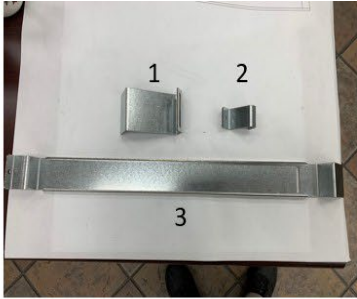

Lid Locking Kit
 1 – Bottom Hinge
 2 - Top Hinge
 3- Lid locking Bar

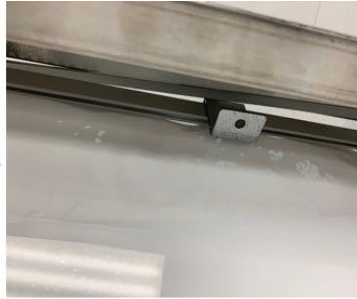

Top hinge part installation
 Lift the Lid to open. It will create a gap at the top and bottom of the lid. Place the top hinge as shown in the picture



Bottom hinge part installation
 Place the bottom hinge on the SS top as shown in the picture above.



Lid locking bar assembly
 Use a lock at top hinge and bottom hinge to restrain any unwanted access.



Lid locking bar assembly
 Place the Lid locking bar as shown above. Make sure the top hinge is aligned and inserted into the slot provide in lid locking bar



Lid locking bar assembly
 Then slowly move the bar towards the lid's inclined surface having a center of rotation at bottom hinge and lid handle



Lid locking bar assembly
 Close the Lid. Hold the Lid locking bar as shown above and insert the bottom flange into the slot of the Bottom hinge

*** For disassemble of the Lid Locking Kit, please follow the process in reverse.**

OPERATION CONDITIONS AND PRESSURES

With room ambient temperature of +75 °F and cold cabinet (unit cycling on control):

DD-66 & DD-88 with R-290

Suction pressure – 2 to 4 psig.

Head pressure – 130 to 160 psig.

DD-26 & DD-46 with R-290

Suctions pressure 1 to 5 psig

Head pressure 130 to 160 psig

SERVICE INSTRUCTIONS (Trouble Shooting Guide)

1. High head pressure and high back pressure:
 - A. Condenser coil clogged or restricted.
 - B. Condenser fan motor defective.
 - C. Air in the system.
 - D. Refrigeration overcharge.
2. Low back pressure and low head pressure:
 - A. Capillary tube restriction.
 - B. Refrigerant undercharged.
 - C. Leak in system.
 - D. Moisture in system.
3. Pressures normal – cabinet warm:
 - A. Refrigerant undercharged.
 - B. Thermostat set too warm.
4. Compressor starts and runs – but cycles on overload:
 - A. Low voltage.
 - B. Overload protector defective.
 - C. High head pressure (see#1).
5. Compressor will not start – hums, but cycles on overload:
 - A. Low voltage.
 - B. Relay defective.
 - C. Overload defective.
 - D. High head pressure (see #1).
6. Cabinet sweating:
 - A. High ambient humidity.
7. Special service situations

CONTROLLER SENSOR PROBE LOCATION

In DD-46, DD-66 & DD-88 models, the bulbwell is a straight 3/8" copper tube placed 3" below the dog house as shown below. For the DD-26 model the bulb well is inverted "L" shape as shown in the picture. Please make sure the bulb well opening is properly insulated with permagum. While replacing the sensor probe please make sure the probe is inserted to the end of the bulb well till it stops. Special care needs to be taken during inserting the probe inside the bulb well so that it is not damaged. **The sensor probe is color coded as shown below. Make sure the probe is fully inserted into the bulb well till the mark up.**

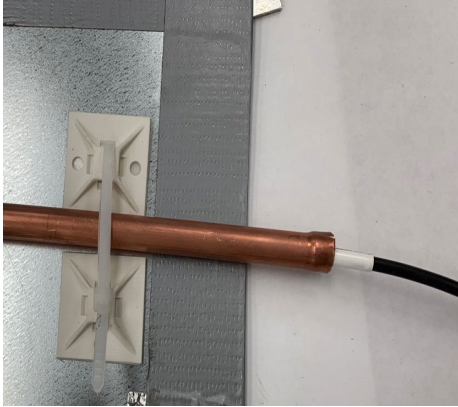

Bulbwell location with sensor probe (representation only)



Sensor probe with bulbwell foamed

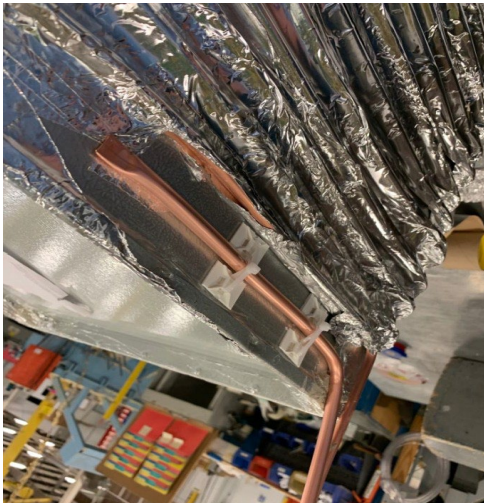

Bulbwell in DD-26



Bulbwell location in DD-46, DD-66 & DD-88

(Part # 19-14785)

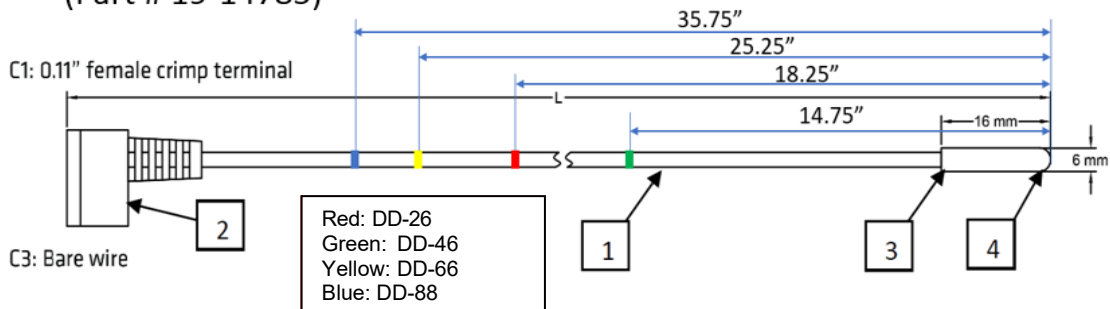

AIR FILTER CLEANING INSTRUCTIONS (Air Filter for DD-66 & DD-88 Fin & Tube Condenser)

The condenser for DD-66 & DD-88 is a 5mm fin and tube condenser. A special removable and reusable air filter has been provided to protect the condenser and avoid it to be blocked by dust. The filter needs to be removed and cleaned periodically for optimum performance of the unit. Find below the pictorial presentation of filter removal and reinstallation after cleaning.



Draining system

The drain outlet is as shown below in the picture.



If moisture or liquid is observed around or under a cabinet, an immediate investigation should be made by qualified personnel to determine the source of moisture or liquid. The investigation made should determine if the cabinet is malfunctioning or if there is a simple housekeeping problem.

Moisture or liquid around or under a cabinet is a potential slip/fall hazard for persons walking by or working in the general area of the cabinet.

Any cabinet malfunction or housekeeping problem that creates a slip/fall hazard around or under a cabinet should be corrected immediately

DIPPING-DISPLAY CABINET PART NUMBERS

Please use the part numbers below when ordering replacement parts for your **DD Series Standard, Low Glass and Low Curved Glass Models**.

Description	DD-26(L)(LCG)	DD-46(L)(LCG)	DD-66(L)(LCG)	DD-88(L)(LCG)
LED Driver	23-01878	23-01878	23-01878	23-01878
LED	23-01947	23-01945	23-01947(2 REQ)	23-01950(2 REQ)
Jumper			23-01951	23-01951
Bracket/Attachment	23-01948	23-01948	23-01948	23-01948
Capillary Tube	11-01306	11-01306	11-01306 (2 REQ)	11-01306 (2 REQ)
Compressor	03-50992	03-50992	03-50996	03-50996
Condenser Coil	07-14190	07-14190	07-14186	07-14186
Condenser Fan Blade	15-13093	15-13093		
Condenser Fan Motor	13-00311	13-00311	13-13453	13-13453
Condenser Fan Motor Bracket	13-00754	13-00754		
Compressor grommet	03-50994	03-50994	03-50994	03-50994
Drier	09-09864	09-09864	09-09864	09-09864
Controller	19-14239	19-14239	19-14239	19-14239
Controller Sensor	19-14785	19-14785	19-14785	19-14785
Top Gasket	(37-01544)(37-01536)	(37-01545)(37-01537)	(37-01546)(37-01538)	(37-01547)(37-01539)
FRONT GLASS				
(Straight Glass Model)	31-03991	31-03992	31-03993	31-03994
(Low Glass Model)	31-03976	31-03977	31-03978	31-03979
(Low Curved Glass)	31-04011	31-04012	31-04013	31-04014
SIDE GLASS				
(Straight Glass Model)	31-03995	31-03995	31-03995	31-03995
(Low Glass Model)	31-03480	31-03480	31-03480	31-03480
(Low Curved Glass)	31-04015	31-04015	31-04015	31-04015
Lid Assembly	A394-14500	A395-14500	A396-14500*	A397-14500*
Light Switch	19-14810	19-14810	19-14810	19-14810
Shelf, Wire	33-01879	33-01879	33-01879	33-01879
Recess Bumper	29-01691	29-01691	29-01691	29-01691
Wire Harness (126" Power Cord)	21-01741	21-01741	21-01741	21-01741
Condenser Air Filter			44-01140	44-01140
Distributor			11-02006	11-02006

*Two lid assemblies required for this model.

OPTIONS

Description	DD-26(L/LCG)	DD-46(L/LCG)	DD-66(L/LCG)	DD-88(L/LCG)
Can Holders – Includes White Can Covers	A394-20301	A395-20301	A396-20301	A397-20301
Can Covers Clear White	44-00984 44-01084	44-00984 44-01084	44-00984 44-01084	44-00984 44-01084
Lid Locking Kit	A390-11129	A390-11129	A390-11129 (2 QTY)	A390-11129 (2 QTY)
Casters Set (4 or 6), 3" Dia.	A039-11140	A039-11140	A044-11140	A044-11140
Dipper Well w/Installation Kit	A060-20400	A060-20400	A060-20400	A060-20400
Frost Shields (Patented)	A390-11150 (DD-26), A394-11150 (DD-26L & DD-26LCG)	A391-11150 (DD-46), A395-11150 (DD-46L & DD-46LCG)	A392-11150 (DD-66), A396-11150 (DD-66L & DD-66LCG)	A393-11150 (DD-88), A397-11150 (DD-88L & DD-88LCG)
Legs 6" leg kit	A039-11170	A039-11170	A044-11140	A044-11140
Flavor Tags	A062-20225 (DD-26 only)	A062-20225 (DD-46 only)	A062-20225 (DD-66 only)	A062-20225 (DD-88 only)

SALE AND DISPOSAL

If you sell or give away your cabinet you must make sure that all safety labels and the Installation - Service Manual are included with it. If you need replacement labels or manuals, we will provide them free. Contact our customer service department at 800-388-5253.

The customer service department should be contacted at the time of sale or disposal of your cabinet so records may be kept of its new location.

If you sell or give away your cabinet and you evacuate the refrigerant charge before shipment, we recommend that the refrigerant charge should be properly recovered in compliance with section 608 of the Clean Air Act effective November 1995 and in accordance with all applicable local, regional, or national standards.

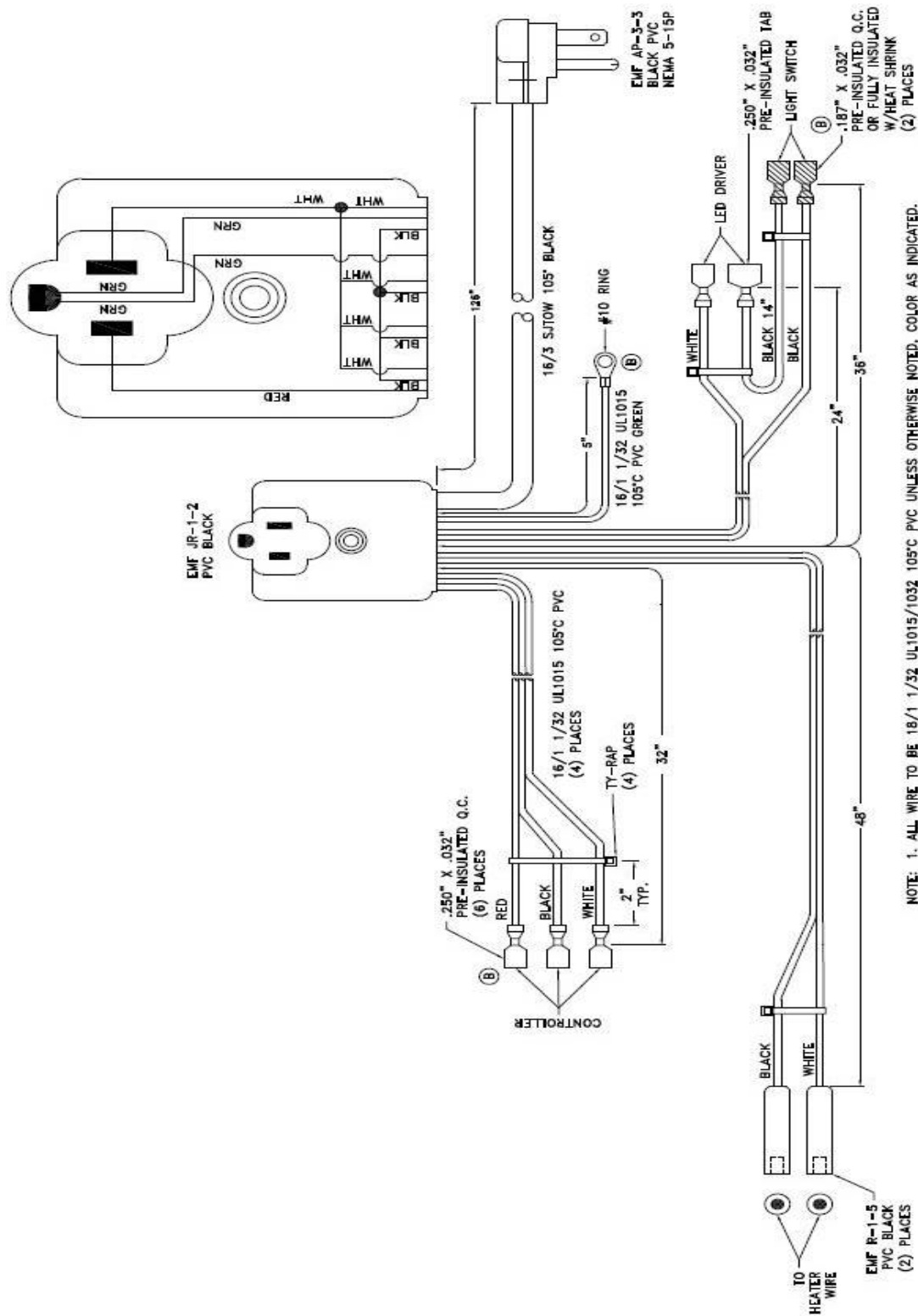

NOTE: 1. ALL WIRE TO BE 18/1 1/32 UL1015/1032 105°C PVC UNLESS OTHERWISE NOTED, COLOR AS INDICATED.
 2. MASTER-BILT P/N MUST MEET UL AND C-UL REQUIREMENTS

WIRING HARNESS WITH MOLDED JUNCTION ASSEMBLY

LED CONNECTION

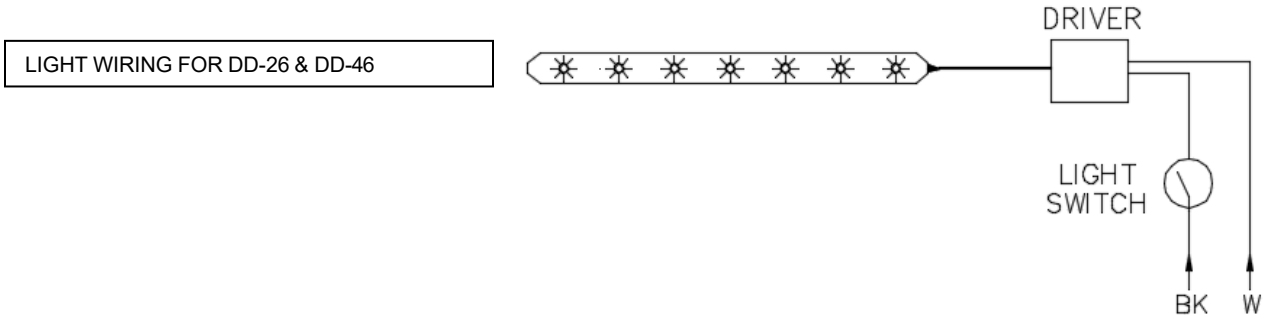
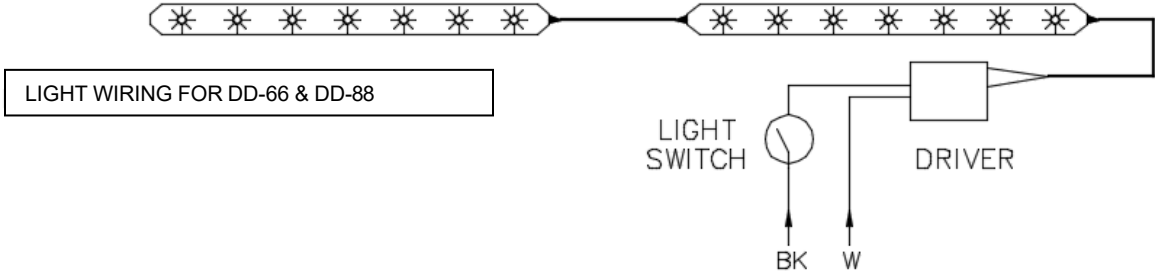

POWER CORD TO CONNECT CONDENSING UNIT

MOLDED JUNCTION ASSEMBLY

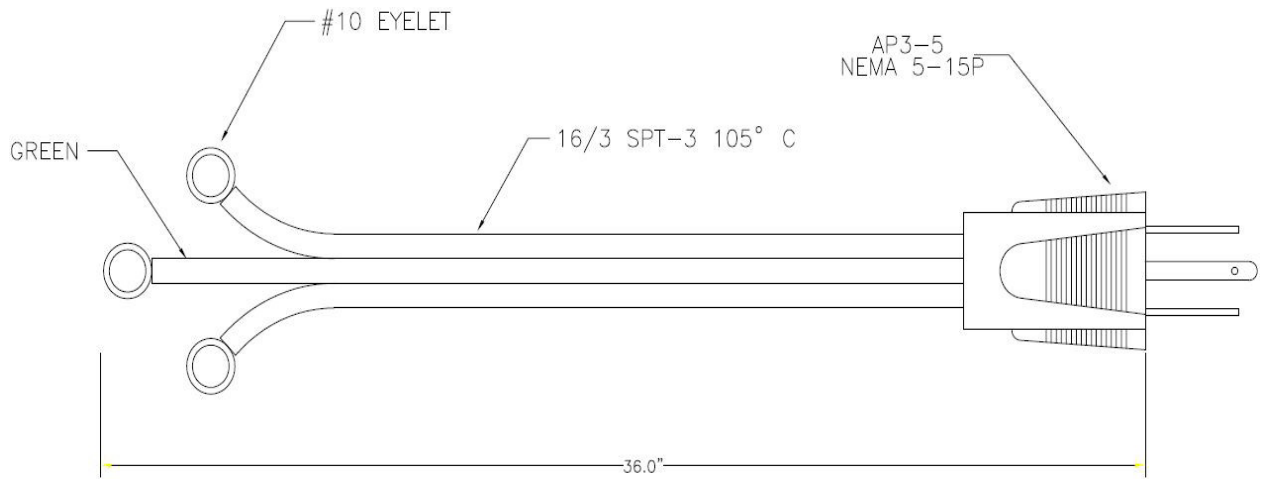

FOR COMPRESSOR WIRING CONNECTION, PLEASE REFER TO THE COMPRESSOR MANUFACTURER WIRING DIAGRAM