

2024

User Manual



HKN-XRCG24-4A 4 burner

Countertop Gas Ranges

Models:

HKN-XRCG12-2A 2 burner

HKN-XRCG24-4A 4 burner

HKN-XRCG36-6A 6 burner

Note:

Please read this manual thoroughly prior to equipment set-up, operation, and maintenance.



www.equip.me

HURAKAN



WARNINGS

- Do not store or use gasoline or other flammable vapors or liquids in the vicinity of this or any other equipment.
- Improper installation, adjustment, alteration, service or maintenance can cause property damage, injury or death.
- Read the installation and maintenance instructions thoroughly before installing or servicing this equipment.
- If you smell gas, follow the instructions provided by the gas supplier.
- Do not try to light the burner; do not use a telephone within close proximity.
- Have the equipment installed by a qualified installer in accordance with all federal, state and local codes.
- Do not install or use this equipment without all four legs securely in place.
- This equipment is designed for use only in non-combustible locations.
- Avoid obstructing the flow of combustion and ventilation air.
- Refrain from spraying liquids or cleaning agents on the controls or the exterior of the equipment.
- Place this equipment in a flat, level position during use.
- Do not operate the equipment without supervision.
- Any loose dirt or metal particles entering the gas lines can damage the valve and impact its operation.
- If you detect a gas odor, follow the instructions provided by the gas supplier. Do not attempt to light the burner, and avoid using a telephone in close proximity.
- Never attempt to move the machine while cooking.
- NEVER use an open flame to check for gas leaks, as it may result in fire and explosion.
- This countertop range comes with a gas pressure regulator. Failure to install the supplied regulator properly may lead to an extremely hazardous condition. Ensure that the flow arrow stamped on the body of the regulator points toward the countertop range, and the vent hole must point UP.
- If the pilot light is extinguished, turn off the gas shut-off valve, remove the grate and drip pan, and allow the appliance to vent for five minutes before attempting to re-light.
- **DO NOT** spill or pour water into burners or controls, and **DO NOT** submerge the countertop range cabinet in water. Water damage to internal components is not covered by the warranty.
- **CAUTION** - Servicing must be conducted by factory authorized service personnel to minimize the risk of ignition from incorrect parts or improper service.



Table of Contents

Features & specifications	4
Installation instructions.....	4
Regular maintenance.....	7
Troubleshooting.....	8

Instructions and images in this manual are only for reference and may differ from the actual product. Launch the E-Manual.

Features & specifications

Model	Style	Gas Type	Manifold pressure	Total B.T.U. per Hour
HKN-XRCG12-2A	2 Burners w/ individual control	Natural Propane	4.0" WC 10.0" WC	50,000
HKN-XRCG24-4A	4 Burners w/ individual control	Natural Propane	4.0" WC 10.0" WC	100,000
HKN-XRCG24-6A	6 Burners w/ individual control	Natural Propane	4.0" WC 10.0" WC	150,000

Installation

IMPORTANT! PLEASE READ BEFORE INSTALLATION:

The installation of this equipment must conform with local codes, or with the National Gas Code, ANSI Z223.1/NFPA 54, or the Natural Gas and Propane Installation Code, CSA B149.1, as applicable.

Uncrating. Tools required

- Adjustable Wrench • Phillips Screwdriver • Level
- Unpack the equipment and remove all packing material, tape, and protective plastic.
- Position and set the equipment at the desired height.
- Attach the four (4) legs to the equipment.
- Prior to use, ensure the equipment is cleaned and thoroughly dried.

Leveling:

- The countertop range must be level (side-to-side and front-to-back) during operation to ensure proper performance. Improper leveling can result in uneven temperature distribution, cold spots, and possibly damaged components.
- 1. Place a level on the countertop range.
- 2. Adjust legs by turning the bullet feet at the bottom of each leg. Using pliers or a crescent wrench, turn the feet counter-clockwise to increase height, and clockwise to decrease height until leveling is achieved. Do not extend the legs more than 1- $\frac{3}{8}$ ".

Ventilation hood

- The countertop range should be installed under a suitable ventilation hood. For safe operation and proper ventilation, keep the space between the countertop range and vent hood free from any obstructions.



SET UP

Pressure testing:

- The equipment and its individual shutoff valve must be disconnected from the gas supply piping system during any pressure testing of that system at test pressures in excess of ½ psi (3.5 kPa).
- The equipment must be isolated from the gas supply piping system by closing its individual manual shutoff valve during any pressure testing of the gas supply piping system at test pressures equal to or less than ½ psi (3.5 kPa).

Clearance and positioning around the equipment:

- This equipment must be installed adjacent to non-combustible surfaces only with a minimum spacing of 6" from all sides. This equipment must be a distance of 6" from other equipment. The equipment must have the 4" legs installed and be placed on a noncombustible surface.

Air Supply and ventilation:

- The area in front and around the equipment must be kept clear to avoid any obstruction of the flow of combustion and ventilation air.
- Adequate clearance must be maintained at all times in front of and at the sides of the equipment for servicing and proper ventilation.

Pressure Regulator:

- All commercial cooking equipment must have a pressure regulator on the incoming service line for safe and efficient operation. The regulator provided for this equipment is adaptable for both Natural Gas and LP gas.
- Regulator specifications: ¾" NPT inlet and outlet, factory adjusted for 4" WC Natural Gas standard and may be converted by qualified personnel to be used for Propane at 10" WC.

Prior to connecting the regulator, check the incoming line pressure. The regulator can only withstand a maximum pressure of ½ PSI (14" WC). If the line pressure is beyond this limit, a step-down regulator before the regulator provided will be required. The arrow above (FLOW) shows gas flow direction and should point downstream to the equipment.

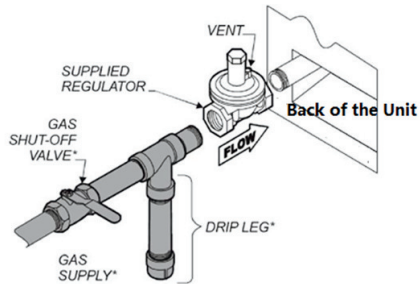

PROPANE GAS CONVERSION

This countertop range is shipped from the factory equipped with fixed burner orifices for natural gas operation. The burner orifices required to convert the countertop range to propane gas are shipped with the countertop range in the shipping packaging. It is recommended that a trained gas service technician with the necessary tools, instruments and skills perform the conversion.

To convert to propane, following steps must be completed:

1. Remove all natural gas burner orifices and install the provided propane burner orifices.
2. Set the regulator to 10" WC by inverting the regulator spring plug like below pictures.

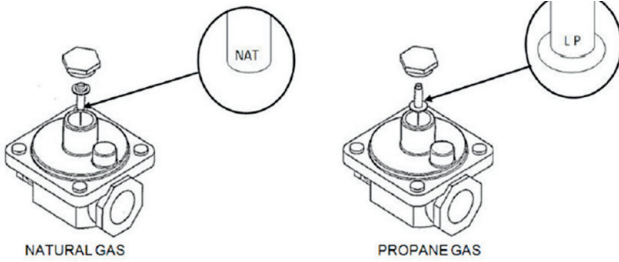

NATURAL GAS

PROPANE GAS

LIGHTING THE PILOT:

The manifold units are equipped with standing pilots and each should be lit immediately after the gas is supplied to the equipment.

1. Before attempting to light the pilots, turn off the main gas valve to the equipment and wait 5 minutes to clear the gas.
2. Turn off all gas control knobs.
3. Turn on control valve and light all pilots.
4. The pilot burner must be lit from the top. Hold an ignition source and light the pilot. When the flame is stable, remove ignition source.
5. Turn off the main gas valve to shut down the equipment.

Smoke appearing on initial start of the equipment is normal. This is a result of the painted coating burning off. Allow the equipment to “burn in” for at least 20 minutes before the first use.

Pilot Flame Height Adjustment:

- The pilot flame on the equipment has been factory adjusted. When adjustment is necessary, adjust the pilot flames as small as possible but high enough to light the burner immediately when the burner valve is turned to the highest setting. Access to the pilot flame adjustment screw is obtained through the holes in the front panel

Burner Adjustment:

- Remove the front panel to gain access. Turn burner valve knob to highest setting. Slowly decrease the air shutters to give a soft blue flame having luminous tips. Then slowly increase opening to a point where the yellow tips disappear and a hard blue flame is obtained.

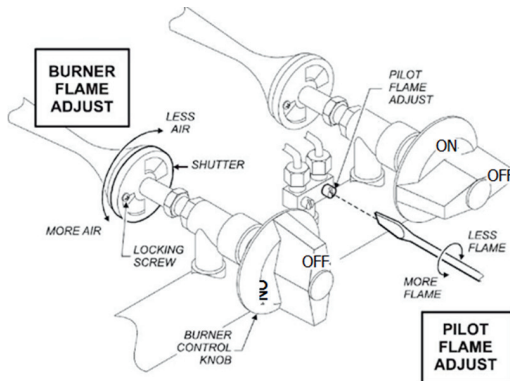

Preheating the countertop range:

Allow the countertop range to preheat for 30 minutes. Rub grates with cooking oil before using

After 20 minutes of burn-in, equipment is ready for use.

OPERATION:

1. To ignite the burners, depress and turn the gas control knob to high position.
2. After cooking is done, please turn the valve to off position.

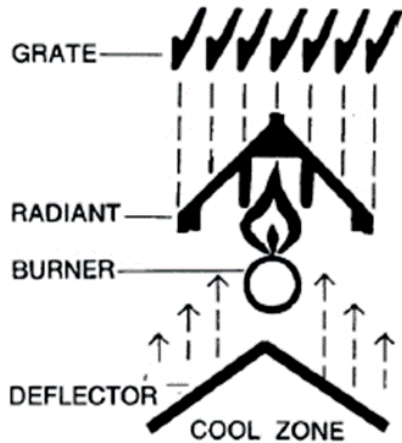

Regular maintenance

Cleaning

To maintain the appearance and increase the service life, clean your equipment daily.

DO NOT clean equipment with steel wool.

- Allow the equipment to cool completely before cleaning.
- Using a wire brush, scrape the grill grate(s) to remove any food residue.
- To clean equipment, use either a damp cloth, sponge with soapy water or a metal scraper.
- Dry grates thoroughly to prevent rusting.
- Empty and clean the drip tray.

Maintenance

- A qualified service company should check the unit for safe and efficient operation on an annual basis.
- Gas piping shall be a certain size and installed to provide a supply of gas sufficient to meet the full gas input of the equipment.
- A manual shut off valve should be installed upstream from the manifold within 4 ft. (1.2m) of the equipment and in a position where it can be reached in the event of an emergency.
- Check entire gas piping system for leaks every so often. Using a gas leak detector or soapy water solution is recommended.
- Install equipment under efficient exhaust hood with flameproof filters with a distance of no less than 4 feet between the top of the equipment and the filters or any other combustible materials.

*Shipped setup for Natural Gas and includes a kit for conversion to LPG

Troubleshooting

Before requesting any service on your unit, please check the following points. Please note that this guide serves only as a reference for solutions to common problems.



Problem	Possible Cause
Burner does not come on when the control knob is turned on	Problem with gas valve. (Call for service).
	Pilot burner not lit.
	Low gas pressure. (Call for service)
Too much heat	Burner valves adjusted too high
	Faulty ventilation
	Overrated gas pressure
	Improperly adjusted burner
Uneven heat side to side	Burner valves improperly adjusted
	Appliance is not level side to side
	Improperly adjusted burner
Uneven heat front to back	Appliance is not level front to back
	Faulty ventilation
	Improperly adjusted burner
Pilot burner will not stay lit	Pilot flame is set too low. Adjust pilot to allow for gas flow.
	Obstruction in pilot orifice
	Low gas pressure. (Call for Service).
Yellow burner flames	Open burner shutters until flames are blue
Lifting burner flames	Close burner shutters until flames touch burner