

# Champion<sup>®</sup>

The Dishwashing Machine Specialists

PROJECT: \_\_\_\_\_

ITEM # \_\_\_\_\_ QTY: \_\_\_\_\_

MODEL # \_\_\_\_\_

AIA # \_\_\_\_\_ SIS # \_\_\_\_\_

## 54 PRO Steam

### HIGH TEMPERATURE STEAM RACK CONVEYOR

HIGH TEMPERATURE STEAM RACK CONVEYOR DISHWASHING MACHINE



Rendered image is for general visual representation only. Please refer to specifications for the latest detailed product information.

#### STANDARD FEATURES

- **Perpetual Rack Advance System**  
with digital jam monitoring, and mechanical drive protection
- **Automated Delime Function**  
with user-customizable alert intervals
- **255 Racks Per Hour**
- **.39 Gallons/Rack With Energy Sentinel** (idle pump shut-off)
- **Advanced Touchscreen Display**  
intuitive condition alerts, with user friendly cleaning and operation visual guidance, multi-lingual
- **Enhanced Visual On-board Diagnostics**  
quickly identify machine faults for rapid resolution and less downtime
- **Automatic Tank Fill**
- **Programmable Machine Dwell**  
pauses rack in wash zone for extended cleaning, NSF Certified Pot & Pan Mode
- **Automatic Drain Valve**
- **Single-Piece Hood Design**
- **Single-Piece Scrap Screen**  
more robust and faster cleaning
- **Single-Piece Stainless Steel Upper And Lower Wash Arm Manifolds**
- **Single-Point Electrical Connection**
- **20" Standard Vertical Clearance**  
accommodates 18" x 26" sheet pans
- **Fully Insulated Doors**  
open a full 180° for unrestricted cleaning access
- **All Stainless Steel Heavy Gauge Construction**  
including base, legs and feet
- **Enclosure Panels** (front and sides)
- **2 HP Pump Motor** with stainless steel impeller
- **Factory Authorized Start-Up**
- **Vent Fan Control**
- **ENERGY STAR® Certified**
- **Made in America**



#### SPECIFIER STATEMENT

Specified unit will be Champion model 54 PRO Steam series high temperature rack conveyor dishwashing machine. Features top mounted prodigy HMI user interface controls with proactive maintenance software, proportional rinse, using only 100 GPH, built-in booster, progressive anti-jam drive system, energy sentinel (idle pump shut-off), 255 racks per hour, single-piece hood design, single-piece stainless steel upper & lower wash arms manifolds, full 180° opening leak proof insulated hinged access doors.

**1 Year parts and labor warranty.**

**In the USA:**  
3765 Champion Blvd, Winston-Salem, NC 27105  
Tel: (336) 661-1556 Fax: (336) 661-1979  
[www.championindustries.com](http://www.championindustries.com)

**In Canada:**  
2674 N. Service Rd., Jordan Station, Ontario, Canada LORISO  
Tel: (905) 562-4195 Fax: (905) 562-4618  
[www.championindustries.com/1canada](http://www.championindustries.com/1canada)

#### ACCESSORIES

- Drain water tempering kit (unmounted)
- Table limit switch, unmounted (recommended on all rack conveyor installations) (unmounted)
  - o WHISKER STYLE
  - o BUTTON STYLE
- Vent cowl, stainless steel with 7" stacks & locking dampers
- Extended vent cowl, with 7" stacks, locking dampers & external curtain
- Flanged feet (unmounted)
- Water hammer kit (unmounted)
- Chemical pump kit (detergent and rinse aid, mounted and interwired)
- Water pressure regulating valve (unmounted; standard with booster)
- ION scale prevention device (unmounted)
- Water softening system (manufactured, warrantied and serviced by Kinetico)
- Dish racks:
  - o PEG RACK
  - o FLAT RACK
  - o SHEET PAN RACK
- Splash shields
- Cantilever sideloader (without hood) for 90° load operation
  - o 24" SIDELOAD
  - o 30" SIDELOAD (ACCEPTS SHEET PANS)
- Model PRO-90B unloader (90° corner conveyor table)
- Model PRO-90B loader (90° corner conveyor table)
- Model RCT 64 or RCT 84 roller conveyor table (see factory for custom length)
- Stainless steel rear enclosure panels
- Correctional package (contact factory)

#### OPTIONS

- 33" Blower dryer – steam
- Direct link connectivity solution
- Direct link plus+ connectivity solution

**Cantilever  
Sideloader**  
(no hood)



**PRO-90B**  
90° Corner Conveyor  
table loader and  
unloader available



**Model RCT 64 or RCT 84**  
Roller conveyor table



#### UTILITIES

<b>1</b>	<b>Electrical Connections</b> Machine electrical connection
<b>2</b>	<b>Hot Water</b> Machine with built-in booster Main connection 1/2" NPT 110° incoming water
<b>4</b>	<b>Hot Water</b> Machine with no booster Main water connection 1/2" NPT 180° incoming water
<b>5A</b>	<b>Drain</b> Connection 1-1/4" NPT Drain Max Flow Rate (g/min) 15
<b>6A</b>	<b>Steam</b> 1-1/4" NPT machine & booster (10-30 PSI) flow pressure
<b>7A</b>	<b>Condensate</b> 3/4" NPT machine return to boiler. <b>No back pressure.</b>
<b>8</b>	<b>Vents</b> A Stack connection – load end 200 CFM @ 1/4" static pressure B Stack connection – unload end 400 CFM @ 1/4" static pressure

**Warning:** Plumbing and electrical connections should be made by qualified personnel who will observe all the applicable plumbing, sanitary, and safety codes and the National Electrical Code.

**Note:** Water Hammer Arrestor (meeting ASSE-1010 standard or equivalent) to be supplied (by others) in common water supply line at service connection.

**Optional Drain Tempering:** 1/2" NPT cold water connection required. 1/2" NPT drain connection from back flow preventer to house drain. (FIELD INSTALLED and PLUMBED).

**Plumbing Notes:** Because of the variation in house-supplied steam and water pressures, steam and water pressure regulating valves (PRVs) may be needed. (Water PRV is standard on machines with booster.) The PRVs can either be purchased from Champion or obtained locally.

Water hardness of 3 grains/US Gal (0.83 Imp Gal) – 5.3 Mg/L or less

**Venting Notes:** Fabricated duct size: 3-7/8" x 15-7/8" (outside dimensions)

#### SPECIFICATIONS

Capacity	
Racks per hr (NSF rated)	255
Wash tank (US gal.)	17
Conveyor speed (ft/min)	7.1
Conveyor speed Pot/Pan Mode (ft/min) (only one rack at a time in pot/pan)	5.4
Motor Horsepower	
Drive	1/6
Wash	2
Water Consumption	
US Gal. per hr (max. use)	100
US Gal. per rack	.39
Heating 10-30 PSI flow pressure	
Tank heat, steam (lbs./hr. required)	75
Steam booster (lbs./hr. required for 70° F rise)	110
Booster heaters completely inter plumbed, controls are interwired.	
Venting	
Load end (minimum CFM)	200
Unload end (minimum CFM)	400
Standard 20"x 20" Rack Complement	
Peg	1
Flat	1

54 PRO Steam Tank Heat with 70°F Rise Booster			
Elec. Specs	Rated Amps	Minimum Supply Ckt. Conductor Ampacity	Maximum Overcurrent Protective Device
208/60/3	10	15	15
240/60/3	9	15	15
480/60/3	5	15	15
575/60/3	4	15	15

# Champion®

The Dishwashing Machine Specialists

## 54 PRO STEAM

### HIGH TEMPERATURE STEAM RACK CONVEYOR

Shipping weight crated: 650 lbs. Dimensions shown in inches

#### Front View

#### Left to Right Model

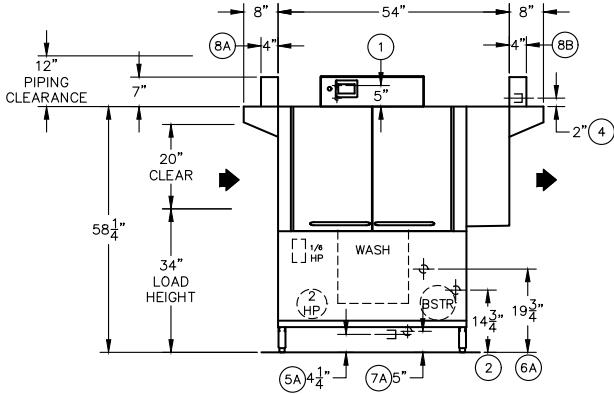

#### Right to Left Model

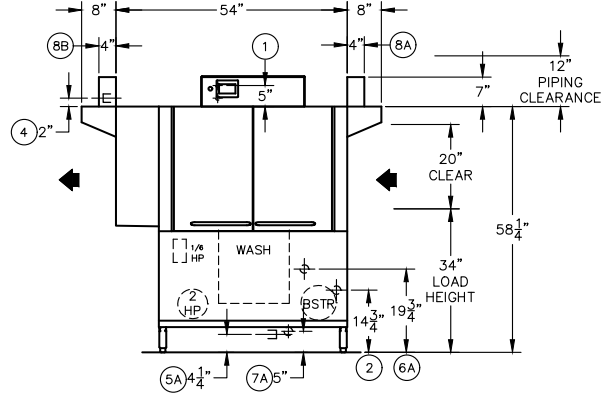

#### Plan View

#### Left to Right Model

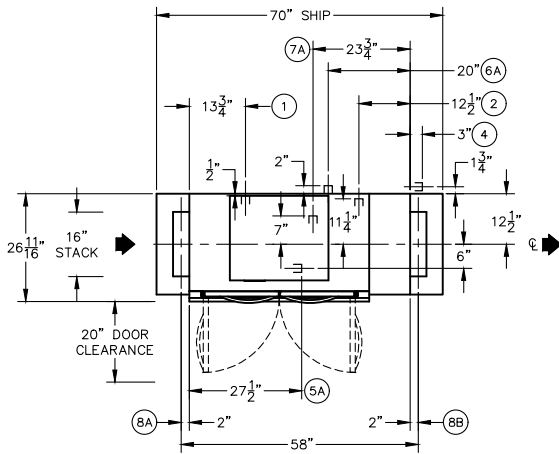

#### Right to Left Model

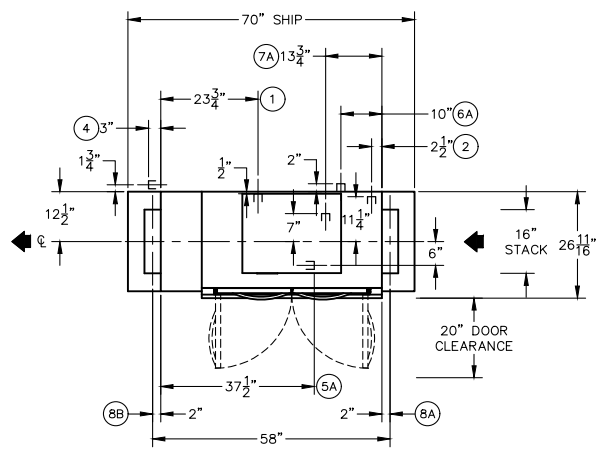

#### End View

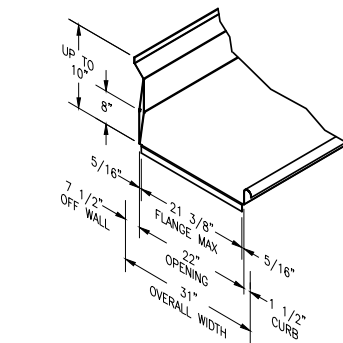
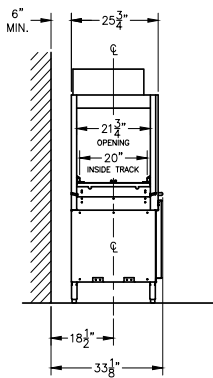

Suggested Table Construction

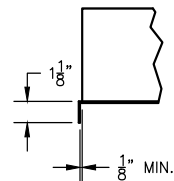

Flange Details

In the USA: 3765 Champion Blvd, Winston-Salem, NC 27105 | Tel: (336) 661-1556 Fax: (336) 661-1979 | [www.championindustries.com](http://www.championindustries.com)

In Canada: 2674 N. Service Rd., Jordan Station, Ontario, Canada LORISO | Tel: (905) 562-4195 Fax: (905) 562-4618 | [www.championindustries.com/1canada](http://www.championindustries.com/1canada)

Rev. 08/2024 Printed in U.S.A.

Due to an ongoing value analysis program at Champion, specifications contained in this catalog are subject to change without notice.