

AN SERIES

BOTTOM MOUNTED REACH-IN
REFRIGERATORS AND FREEZERS
SOLID DOORS



 Infrico

USA

MODEL: IRR-AN23 · IRR-AN49 · IRR-AN67 / IRR-AN23BT · AN49BT · AN67BT

REACH IN: Bottom Mounted Reach-In Refrigerators & Freezers

GENERAL FEATURES 



- ✓ **Higher energy efficiency.** R290 refrigerant with electronic fans, LED lighting and evaporative tray without electric resistances.
- ✓ **Sanitation.** Our units feature a hygienic design with rounded corners that have a large radius, making them easy to clean. Additionally, the shelves and slides can be quickly removed for thorough interior cleaning. Each unit is equipped with a drain trap at the bottom to facilitate cleaning.
- ✓ **Doors.** Self-closing door system features a permanent pressure mechanism, ensuring a secure closure every time. Additionally, a convenient 'stay open' feature engages when the door remains open at 95 degrees or beyond. Our doors also include triple chamber door gaskets that are easy to remove and snap in, ensuring an effective seal. Plus, for added flexibility, our doors are **field reversible**, allowing for easy installation and use in a variety of settings.

- ✓ **Control System.** Our temperature management system offers unparalleled precision, allowing for highly accurate temperature settings. With greater flexibility in adjusting temperature ranges, our system can be tailored to meet the unique needs of each end user. This ensures optimal performance and maximum satisfaction with every use.
- ✓ **Lighting.** LED lighting reduces the consumption by 80% to 90% compared to traditional bulb, better light quality.
- ✓ **100% Tested.** All condensing units undergo rigorous testing in helium chambers for refrigerant leak detection and a final equipment test in a state-of-the-art test room.
- ✓ **Certified.** Audited and Certified by INTERTEK for compliance with UL 471 and NSF 7.

MODEL:	IRR-AN23 · IRR-AN49 · IRR-AN67 / IRR-AN23BT · AN49BT · AN67BT
REACH IN:	Bottom Mounted Reach-In Refrigerators & Freezers

STANDARD FEATURES

✓ Exterior

AISI 304 Stainless Steel.

✓ Interior

- AISI 430 Stainless Steel with a 304-interior bottom.
- Sealed interior floors and rounded cabinet corners.
- LED lighting.
- Internal drain trap for easy cleaning.

✓ Door

- Polyurethane insulated solid door.
- Self-closing door with stay open feature.
- Stainless Steel heavy-duty hinges.
- Triple chamber snap in door gaskets for easy removal and cleaning.
- Field reversible door [hardware needed].
- Heated door frame to avoid ice accumulation. [Freezers only]
- Door locks.
- Full-height door opening: 23"x 53" [584 x 1.346 mm].

✓ Insulation

- CFC-Free polyurethane insulation, entire cabinet structure is foamed-in using a high-density polyurethane insulation.
- Low GWP & Zero ODP effect.

✓ Casters

- 4" Diameter casters already installed.
- Locks provided on front set.

✓ Shelving

- [3] Three plastic coated wire shelves per door with stainless steel tray slides included.
- Dimensions WxD: 20-7/8" x 25-5/8" [530 x 650 mm].
- Tray slides are compatible with 18" x 26" [457 x 660 mm].

✓ Refrigeration

- Digital temperature controller with automatic defrost system.
- Hinged control panel, easily removable.
- Energy-saving non-electric condensate pan.
- Evaporator coil coated with anti-corrosion material 100% Polyester.
- Expansion valve [Freezers only].

✓ Refrigeration capacity

- IRR-AN23 – 1.468 Btu / h [14°F] / 430W [-10°C].
- IRR-AN49 – 2.344 Btu / h [14°F] / 687W [-10°C].
- IRR-AN67 – 3427 Btu / h [14°F] / 1.004W [-10°C].
- IRR-AN23BT – 3728 Btu / h [-22°F] / 1.092W [-30°C].
- IRR-AN49BT – 4083 Btu / h [-22°F] / 1.196W [-30°C].
- IRR-AN67BT – 7456 Btu / h [-22°F] / 2.184W [-30°C].

✓ Electrical

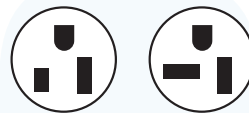

NEMA 5-15 NEMA 5-20

- Cord and NEMA 5-15P plug. [Refrigeration and Freezers]
- Cord and NEMA 5-20P plug. [IRR-AN67BT Only]
- Electrical connection is 115V / 1ph / 60 Hz.

✓ **ETL Listed to UL471 Standard and Sanitation classified to NSF7.**

OPTIONAL FEATURES

- ✓ Stainless Steel wire shelf.
- ✓ Additional slide kits.
- ✓ Set of 6" legs, height adjustable from 5" to 8".
- ✓ Electrical connection 230V / 1ph / 50Hz [Plug type and consumption varies].

MODEL: IRR-AN23 · IRR-AN49 · IRR-AN67 / IRR-AN23BT · AN49BT · AN67BT

REACH IN: Bottom Mounted Reach-In Refrigerators & Freezers

MODELS	DIMENSIONS			DOORS	SHELVES	REF	Ref. Weight [Lbs.] [gr.]	Temp. Range [°F] [°C]	Cond Unit [H.P]	Capacity [Cu.Ft] [L]	Case Amps 115V	Crated Weight [Lbs.] [Kg.]
	W	D	H									
IRR AN23	27 [687]	31-3/8 [796]	83-5/32 [2.112]	1	3	R290	0,22 [110]	33F° / 38F° [0°C / 4°C]	22 [610]	1/4	3,8	440 [200]
IRR AN49	54-1/2 [1.384]	31-3/8 [796]	83-5/32 [2.112]	2	6	R290	0,28 [130]	33F° / 38F° [0°C / 4°C]	48 [1.350]	1/3	4,0	610 [277]
IRR AN67	82 [2.081]	31-3/8 [796]	83-5/32 [2.112]	3	9	R290	0,33 [150]	33F° / 38F° [0°C / 4°C]	67 [2.100]	3/4	6,1	771 [350]
IRR AN23BT	27 [687]	31-3/8 [796]	83-5/32 [2.112]	1	3	R290	0,26 [120]	0°F [-18°C]	22 [610]	3/4	7,5	440 [200]
IRR AN49BT	54-1/2 [1.384]	31-3/8 [796]	83-5/32 [2.112]	2	6	R290	0,31 [140]	0°F [-18°C]	48 [1.350]	1-1/2	8,7	610 [277]
IRR AN67BT	82 [2.081]	31-3/8 [796]	83-5/32 [2.112]	3	9	R290	0,33 [150]	0°F [-18°C]	67 [2.100]	3/4 + 3/4	14,0	771 [350]



RGB LED lighting (standard)



Natural refrigerant R-290 GWP = 0

PLAN VIEW

IRR-AN23 · IRR-AN23BT

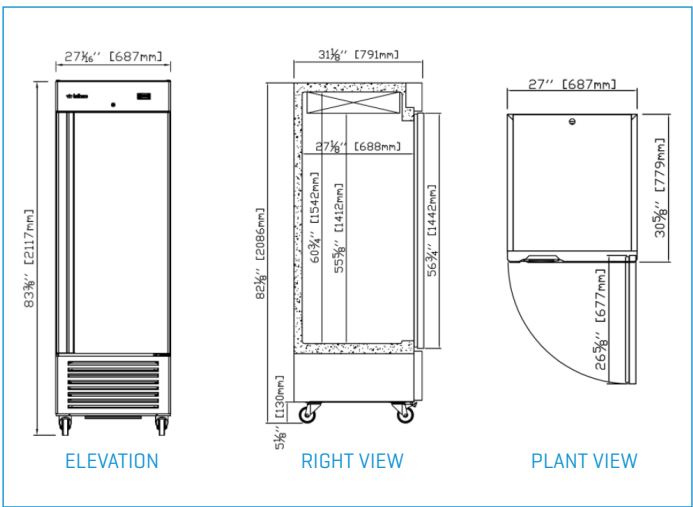

IRR-AN49 · IRR-AN49BT

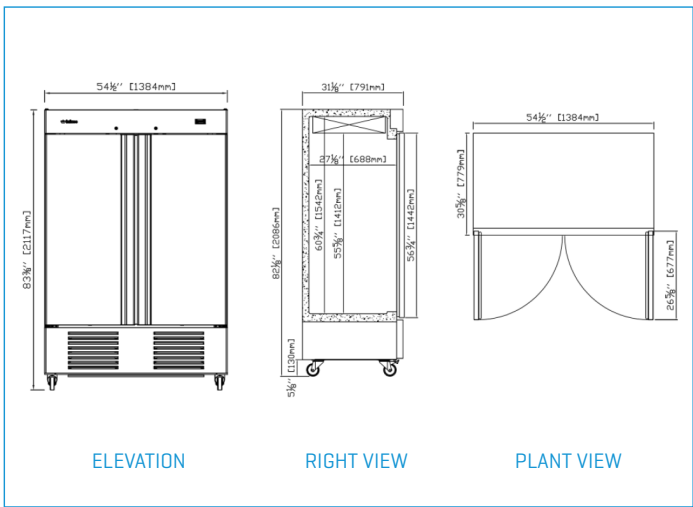

MODEL: IRR-AN23 · IRR-AN49 · IRR-AN67 / IRR-AN23BT · AN49BT · AN67BT

REACH IN: Bottom Mounted Reach-In Refrigerators & Freezers

PLAN VIEW 

IRR-AN67 · IRR-AN67BT

