



# XAF STATIONS

## MODEL: XAFS-193-2

The XAF Station is a heavy duty, manual control oven featuring two XAF convection ovens, stacked on the OST Cadco stand, offering enhanced capacity and efficient cooking.

It's compact and easy-to-manage and perfect for establishments requiring high-volume cooking with minimal space.

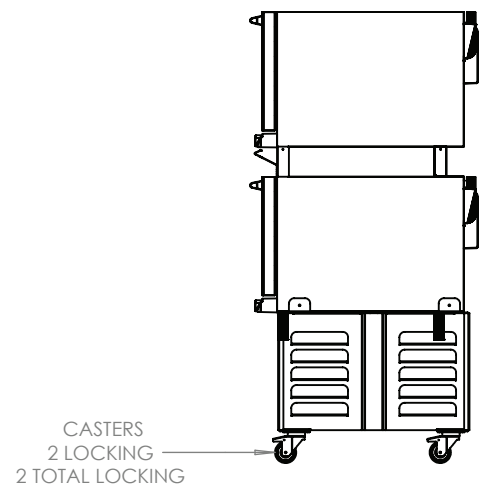
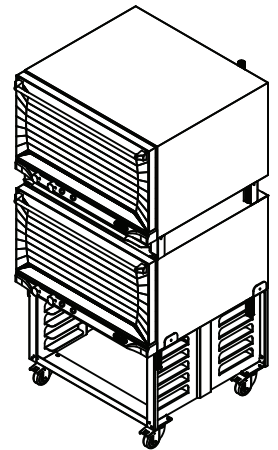
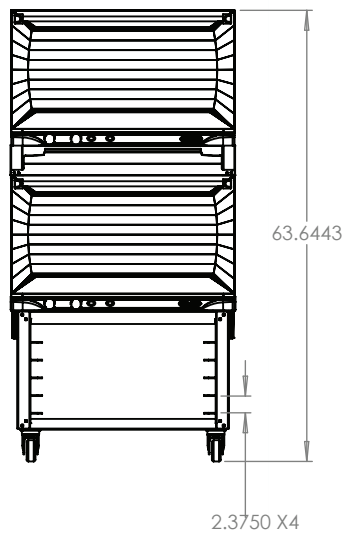
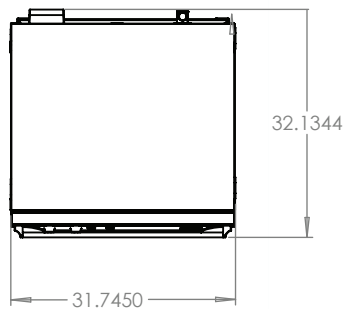

### SPEC FOR EACH XAF-193

Unit Dimensions (W" x H" x D"): 31 1/2 x 23 x 32  
Cavity Size (W" x H" x D"): 27 1/4 x 13 x 18 3/4; 3.85 cft.  
(Two fans. NEMA L6-30 plug.) Shelves: 4  
Volts: 208-240 Watts: 5600 Amps: 24.6

### SPEC FOR CXC 646 (Stacking Kit)

Unit Dimensions (W" x H" x D"): 31.5" x 4"  
Stainless front piece with integral columns, heat baffle  
Stainless back piece with integral columns  
Screws, Bottom oven vent extension & clamp  
90 day warranty

### SPEC FOR OST-195-CS

Unit Dimensions (W" x H" x D"): 31.71" x 23" x 27"  
Handles 5 FULL Size Sheet pans ( not included)  
Can hold two full size cadco ovens  
Short Heavy-Duty Stand w/ Wheels for full size ovens

XAFS-193-2 will ship as two pallets. Pallet #1: 38x35x56 (250lbs ) Pallet #2: 38x35x28 (190lbs)



[www.cadco-ltd.com](http://www.cadco-ltd.com)



860.738.2500



[info@cadco-ltd.com](mailto:info@cadco-ltd.com)