

Blueair by
BLUENIX

MODEL BACB86M-HC CHEF BASE



Stainless steel cabinet construction

Stainless steel interior and exterior (galvanized steel back & bottom).



Temperature range between 33°F ~ 39°F

Air guard on rear wall ensures proper air circulation and cooling.



Hydrocarbon refrigerants (R-290)

Increases energy HFC refrigerants. It is safer for the environment and does not cause ozone depletion.



Exterior Dimensions (inches/mm)

L	D	H
86 1/4" 2192 mm	31" 787.5 mm	25 1/2" 648 mm

Weight (lbs/kg)

Net Weight 317 lbs 143 kg	Ship Weight 348 lbs 157 kg
---------------------------------	----------------------------------

Cabinet construction

- High density foamed in place polyurethane insulation – Environmentally safe
- Designed to accommodate countertop cooking equipment
- Unit accommodates 4" deep food pans. Pans not included
- Heavy duty top panel
- Four (4) 4" diameter swivel casters with front brakes standard.

Refrigeration

- Self-contained system, rear mounted compressor.
- Electrodeposition coated evaporator increases performance by maintaining the heat transfer rates over the life of the evaporator and reducing potential corrosion.
- Innovative hot gas frame heating system reduces condensation and increases energy.

Drawers

- Supported on stainless steel telescoping drawer slides with stainless steel roller bearing wheels
- Drawer slides withstand maximum of 200 lbs. per drawer without deflection
- Upper and lower drawers accommodate 4" deep 12" x 20" pans
- Heavy-duty pan adapter bars supplied for fullsize pans (Pans not included)
- Durable gasket with easy replacement
- Lifetime guaranteed heavy duty all metal door handles. (Ni-Cr Plated)
- 6" Legs available

Front view

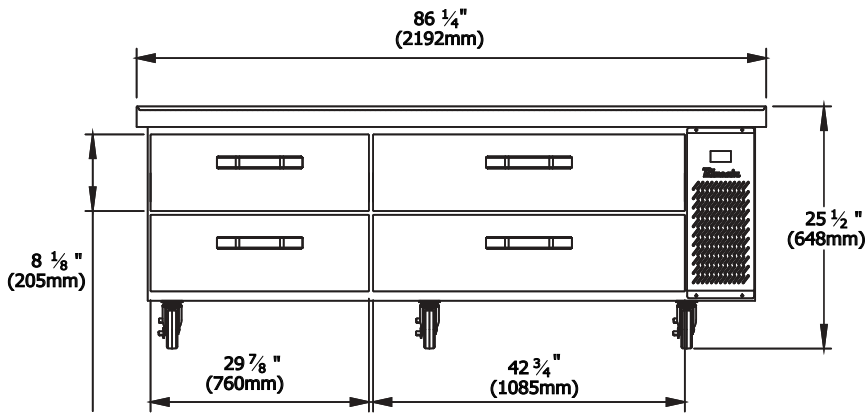

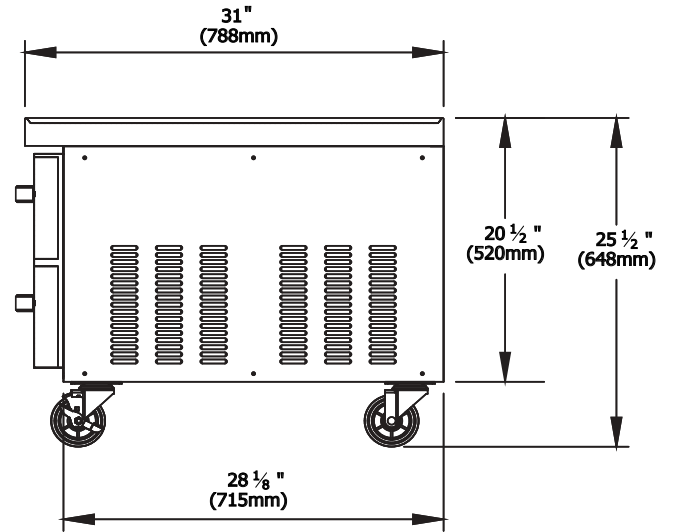

Side view

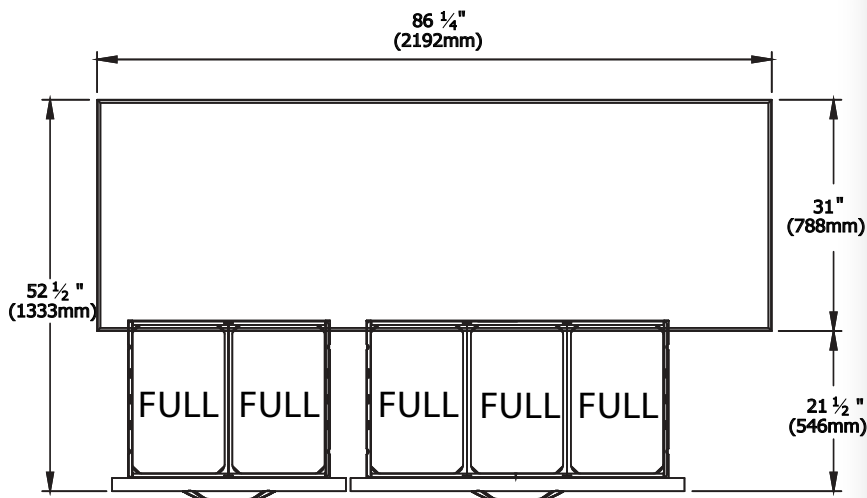

Top view



Drawers	4
Capacity Cu.Ft.	17.2
Refrigerant	R-290
Temperature Range	33°F ~ 39°F
Easy Maintenance	Sliding Condensing Unit
Connection	9.8 ft long (3m) flexible three wire cord with modeled plug
HP	3/8
Voltage	115V/60Hz
Amps	3.5
NEMA Config.	NEMA 5-15



- This product may expose you to chemicals including Diisononyl Phthalate(DINP), which is known to the State of California to cause cancer. For more information go to www.P65Warnings.ca.gov.
 - Ce produit peut vous exposer à des agents chimiques incluant le Diisononyl Phthalate(DINP), reconnu par l'Etat de Californie comme causant le cancer. Pour de plus amples renseignements, consulter le site www.P65Warnings.ca.gov.

Blueair by
BLUENIX

Blue Air has right to change specifications without further notice.

 blueairfse.com

 orders@blueairfse.com



223 W. Rosecrans Ave., CA 90248
T: 310-808-0102

9 W. Shelton Terrace #A, Hillside, NJ 07205
T: 470-625-0182

7025 Amwiler industrial Drive, Suite A, Atlanta GA
T: 908-688-0970