

Technical data sheet for

H10D-FS HOLDING CABINET - FULL SIZE

10 Tray Electric Holding Cabinet DIGITAL CONTROL



STANDARD FEATURES

- Designed for individual use or system installed with Turbofan E32D Convection Ovens
- 10 full size 18" x 26" sheet pan capacity
- 27/8" / 74mm tray spacing
- Compact 287/8" / 735mm width
- 208-240V plug-in 15A NEMA 6-15P cordset fitted
- 1900W (240V), 1430W (208V) cabinet heating
- Full double skin construction
- Digital display Temperature and Timer controls
- Large easy view 3/4" / 20mm high displays
- Electronic temperature control
- 3 hold timers
- Continuous door seal
- Low velocity circulation fan system
- Dual halogen cabinet interior lamps
- Cabinet drain to condensate pan
- 4 dia. 3" / 76mm castors with 2 front castors with wheel and swivel lock, 2 rigid rear castors
- 100% recyclable packaging



H10D-FS

Unit shall be a Moffat electrically heated Turbofan Holding Cabinet. E.T.L listed and NSF.4 listed. The holding cabinet shall have double skin construction with stainless steel interior and exterior sides, front and top. Door shall be side hinged. Unit shall have capacity for 10 full size 18" x 26" sheet pans. A single speed fan shall gently and evenly circulate air around the cabinet. Cabinet shall be controlled by a Digital display electronic Temperature and Timer controller. 3 hold timers shall be standard. Holding cabinet shall be mounted on castors, with two rigid castors at rear and two castors, swivel and wheel lock at front. Holding Cabinet shall operate independently or in conjunction with Moffat Turbofan E32D Convection Oven. Holding Cabinet shall be fitted with a NEMA 6-15P cordset. Unit shall be supplied in 100% recyclable shipping packaging.

H10D-FS 10 Tray Electric Full Size Holding Cabinet DIGITAL CONTROL

CONSTRUCTION

304 stainless steel interior cabinet
Stainless steel front, sides and top exterior
Stainless steel interior side racks
Stainless steel frame, side hinged door
0.2"/5mm thick door glass
Stainless steel control panel
Aluminised coated steel rear panels
Stainless steel base

CONTROLS

Electronic controls with Digital Time and Temperature displays
Large ¾" / 20mm high LED displays
ON/OFF key
Cabinet lamp key
Temperature set and actual key
3 timer keys
Timer range up to 4 hours
Timers countdown or count-up modes
Temperature range 68-194°F / 20-90°C

CLEANING

Stainless steel top and side exterior panels
Removable plug-in oven door seal (no tools required)

SPECIFICATIONS

Electrical Requirements
208-240V, 60Hz, 1-phase, 2.05kW, 8.5A
NEMA 6-15P cordset fitted

External Dimensions

Width 28 7/8" / 735mm
Height 40" / 1015mm including dia. 3" / 76mm castors
Depth 31 7/8" / 810mm

Nett Weight
194 lbs / 88kg

Packing Data

236lbs / 107kg
34.3 ft³ / 0.97m³
Width 30 3/4" / 780mm
Height 51" / 1295mm
Depth 37 7/8" / 960mm

INSTALLATION CLEARANCES

Rear 1" / 25mm
LH Side 0" / 0mm
RH Side 0" / 0mm

CLEARANCE FROM SOURCES OF HEAT

A minimum distance of 12" / 300mm from the appliance sides is required



www.moffatusa.com
www.turbofanoven.com

U.S.A.

Moffat Inc
3765 Champion Boulevard
Winston-Salem
North Carolina 27105
Ph Toll Free 1-800-551 8795
Ph 336-661 0257
Fax 336-661 9546
Email sales@moffat.com
www.moffatusa.com

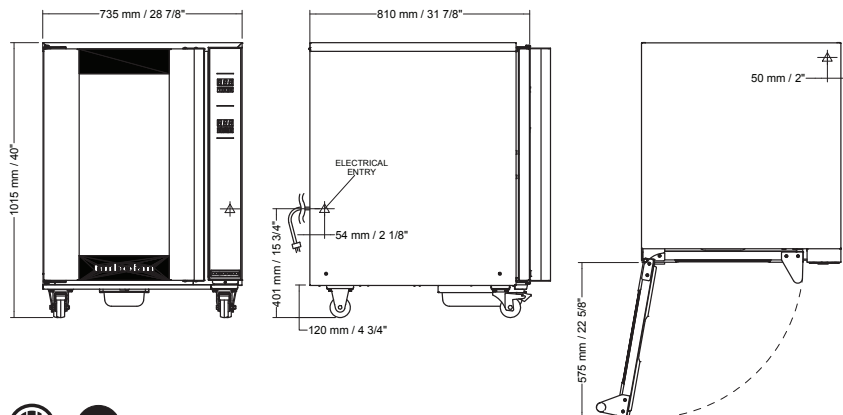

Manufactured by:
Moffat Limited
45 Illinois Drive, Izone Business Hub
Rolleston 7675, New Zealand



ISO9001
Quality
Management
Standard

Designed and manufactured by



ISO9001

All Turbofan products are designed and manufactured by Moffat using the internationally recognised ISO9001 quality management system, covering design, manufacture and final inspection, ensuring consistent high quality at all times.

In line with policy to continually develop and improve its products, Moffat Limited reserves the right to change specifications and design without notice.

© Copyright Moffat Ltd
US.TFN.S.1701

an Ali Group Company



The Spirit of Excellence