

IP 80 XP BA IP 120 XP BA IP 180 XP BA

Meat mixers, floor



- 170, 260 and 397 lbs. double paddle mixers allow for a fast, homogenous yet gentle mix of a variety of products - from sausage meat to potato salad, coleslaw and sandwich fillings - with great sales appeal and longer shelf-life
- Complete stainless steel construction
- Forward and reverse mixing action allows for more control over the most delicate products
- Paddles are easily removed for cleaning
- Tilting tub for easy product discharge and cleaning

Features

Technical

- Completely made from stainless steel.
- Stainless steel paddles for a thorough mixing and a faster kneading.
- Stainless steel tub tilts for easy product emptying
- Fast cleaning and maintenance

Safety

- A safety interlock stops the machine when opening the lid.
- Overload and no volt release protection

Sanitary

- Removable paddles for an easy and accurate cleaning.

Specifications

Motor IP 80:	1.5 Hp (1100W), fan-cooled.
Motor IP 120:	3 Hp (2250W, fan-cooled.
Motor IP 180:	3 Hp (2250W, fan-cooled.
Electrical IP 80:	220V AC, 60Hz, Single Phase.
Electrical IP 120:	220V AC, 60Hz, 3Phase, 5.8 Amps
Electrical IP 180:	220V AC, 60Hz, 3Phase, 5.8 Amps
Plug and Cord:	Attached, flexible, 3 wire or 4 wire (3PH+1G) SJT 14 AWG, 6'4" long cord.
IP 80:	NEMA 6-20 P
IP 120-180:	3Phase hardwired
Controls:	ON/OFF/REV stainless steel keypad, IP 67 waterproof protection. No voltage release.

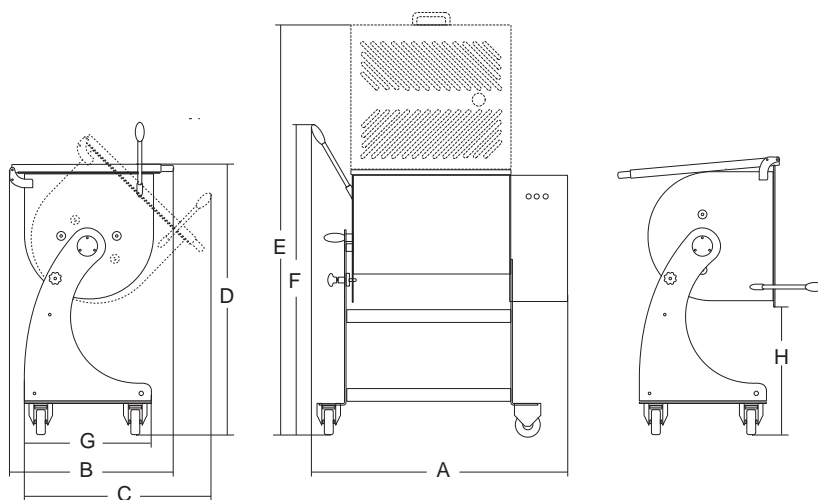
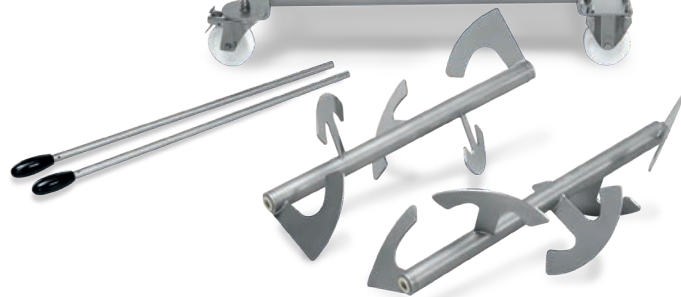

	Power	Power source	Tank dimensions	Capacity	Tank dimensions								Net weight	Shipping	Gross weight
	watt/Hp		inch.	lbs.	A	B	C	D	E	F	G	H	lbs.	inch.	lbs.
IP 80 XP BA	1100/1,5	220V 60Hz 1-phase	24 ^{13/32} " x 19 ^{11/16} "	170	39 ^{3/8} "	24 ^{51/64} "	28 ^{47/64} "	40 ^{35/64} "	63 ^{21/32} "	48 ^{1/32} "	19 ^{11/16} "	18 ^{27/64} "	198	32" x 48" x 60"	242
IP 120 XP BA	2250/3	220V 60Hz 3-phase	25 ^{53/64} " x 21 ^{21/32} "	260	42 ^{53/64} "	27 ^{9/16} "	33 ^{21/32} "	40 ^{35/64} "	67 ^{19/32} "	47 ^{19/32} "	24 ^{19/32} "	14 ^{1/16} "	304	58" x 30" x 52"	380
IP 180 XP BA	2250/3	220V 60Hz 3-phase	39 ^{11/64} " x 21 ^{21/32} "	397	55 ^{53/64} "	27 ^{9/16} "	33 ^{21/32} "	40 ^{35/64} "	67 ^{19/32} "	47 ^{19/32} "	24 ^{19/32} "	14 ^{1/16} "	335	58" x 30" x 52"	420