

# BASE MODEL REFRIGERATOR

## Model: RA43NBS

Natural Refrigerant R-290 Model

### 43" Base Worktop Refrigerator with Solid Doors and 5½" Backsplash



ENERGY STAR® Qualified Commercial Refrigerator

Heavy gauge #300 Series stainless steel top, stainless steel front and end panels, galvanized steel rear and grill and aluminum interior.



## Options and Accessories

(upcharge and lead times may apply)

|   |                                     |
|---|-------------------------------------|
| Stainless steel interior                                  | Different size casters              |
| Stainless steel back                                      | Adjustable legs                     |
| Additional epoxy coated steel shelves                     | Door locks                          |
| Stainless steel shelves                                   | Front breathing                     |
| Overshelves (single or double)                            | Compressor left (standard on right) |
| Pan slides  | Drawers in lieu of doors**          |
| Drawer in lieu of door section above the condensing unit* |                                     |

Consult factory for other model configurations, options and accessories.

\*Drawer section above condensing unit holds (1) 12 x 20 x 6 pan.

**Continental**  
Refrigerator



Project Name:

Model Specified:

Location:

Item No:

Quantity:

AIA #:

SIS #:

## Standard Model Features

### REFRIGERATION SYSTEM

Performance rated refrigeration system

Natural, environmentally safe, high efficiency R-290 refrigerant<sup>1</sup>

Unique forced air design utilizes fans (approx. every 12") across the entire back of unit for even distribution of cold

Automatic, hot gas condensate evaporator

Non-corrosive, plasticized fin evaporator coil

Easily serviceable, slide out condensing unit

Expansion valve system

### CABINET ARCHITECTURE

2" non-CFC polyurethane foam insulation

Smooth, polished chrome door handles

Spring loaded, self closing doors

Magnetic snap in Santoprene™ door gaskets

Heavy duty, epoxy coated steel shelf

Completely enclosed, vented and removable rear and side grills

5" casters

### MODEL FEATURES

Electronic control, off cycle defrost

Refrigerated section with door above the condensing unit

Field rehingeable doors

<sup>1</sup> R-290 refrigerant meets all federal and state regulatory requirements.

**NOTE:** Models come standard with a door over the condensing unit. A drawer over the condensing unit is an option.

APPROVAL:

# Model Specifications

## DIMENSIONAL DATA

|  |                  |
|--|------------------|
| Net Capacity (cubic feet)                                | 12 (340 cu l)    |
| Width, Overall (inches)                                  | 43 (1092 mm)     |
| Depth, Overall (inches)<br>(including handles & bumpers) | 36 9/16 (932 mm) |
| Height, Overall (inches)<br>(including 5" casters)       | 40 1/2 (1029 mm) |
| Shelf Area (square feet)                                 | 5.6 (0.5 sq m)   |
| Number of Shelves  | 2                |
| Number of Full Doors                                     | 1                |
| Number of Half Doors                                     | 1                |
| Interior Depth (inches)                                  | 30 (762 mm)      |
| Interior Height (inches)                                 | 26 (660 mm)      |
| Interior Height (inches)<br>(above condenser)            | 12 1/2 (318 mm)  |
| Interior Width (inches)                                  | 39 (991 mm)      |

## REFRIGERANT DATA

|                             |      |
|-----------------------------|------|
| Condensing Unit Size (H.P.) | 1/4+ |
| Capacity (BTU per hour)*    | 2610 |

## ELECTRICAL DATA

|  |                     |
|--|---------------------|
| Voltage (International)                        | 115/60/1 (220/50/1) |
| Total Amps (International)                     | 4.5 (3.1)           |
| 10 ft. Cord/Plug [attached]<br>(International) | Yes<br>(No)         |

## SHIPPING DATA

|                          |                  |
|--------------------------|------------------|
| Weight (pounds)          | 350 (159 kg)     |
| Height - Crated (inches) | 43 3/4 (1111 mm) |
| Width - Crated (inches)  | 45 (1143 mm)     |
| Depth - Crated (inches)  | 47 (1194 mm)     |

\* Rating @ +25°F evaporator, 90°F ambient  
Figures in parentheses reflect metric equivalents rounded to the nearest whole unit.



Equipped with one NEMA-5-15P Plug  
(varies by country)

# Model Plan Views

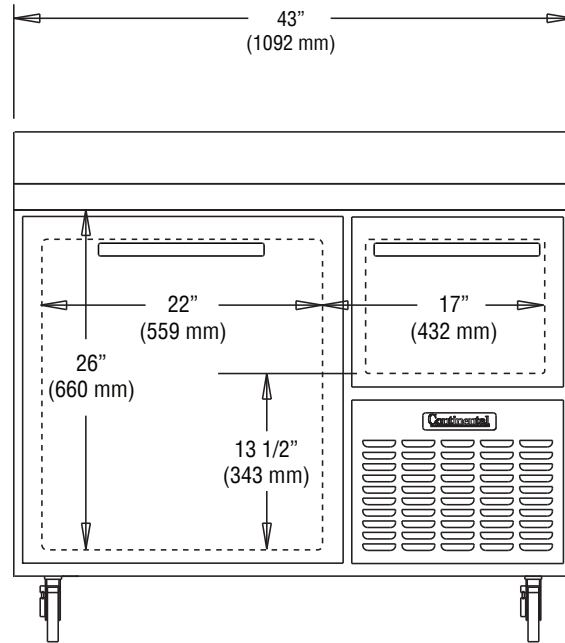

FRONT VIEW

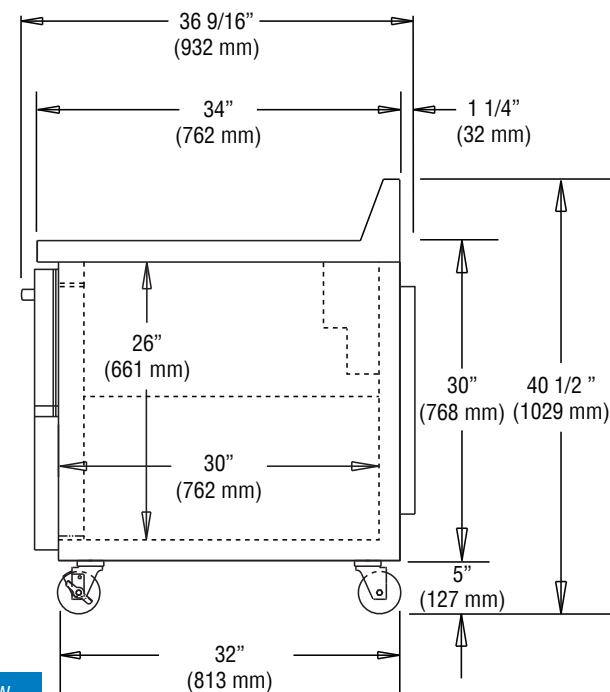

SIDE VIEW

**IMPORTANT NOTE:** If the cabinet is located directly against a wall, a minimum clearance of 3" is required on sides, front and rear.

**Continental**  
Refrigerator

Toll-Free: 800-523-7138  
Phone: 215-244-1400  
Fax: 215-244-9579

539 Dunksferry Road  
Bensalem, PA 19020  
[www.continentalrefrigerator.com](http://www.continentalrefrigerator.com)

Due to our continued efforts in developing innovative products, specifications subject to change without notice.



PROUDLY  
DESIGNED & ASSEMBLED  
IN THE U.S.A.