



BEVERAGE-AIR

Project: _____	AIA#
Item: _____	
Location: _____	SIS#
Approved: _____	

DUAL TEMP WORKTOP

WTRF48AHC Two Door Refrigerator/Freezer Hydrocarbon Series

MODEL:
WTRF48AHC



7 Year Parts/Labor Warranty
7 Year Compressor Warranty

CABINET CONSTRUCTION

- Stainless steel front, sides, doors, and grille (galvanized back & bottom)
- Interior liner is made of corrosion resistant aluminum
- Stainless steel top
- 4" Removable backsplash
- Dual Temp: left side refrigerator, right side freezer units provide two different operating temperature zones for different types of products
- Full electronic control
- Interior thermometer is standard
- Self-closing doors with 120° stay-open feature, on cartridge style hinges
- Magnetic gasket attached to each door for positive seal
- Painted aluminum door handles
- 6" Casters, two (2) with brakes standard
- Four (4) epoxy-coated steel wire shelves
- Field reversible doors (hinge kit required)

OPTIONS & ACCESSORIES

- Stainless steel back
- Stainless steel interior
- Right or left hinged door
- Locks (doors only)
- Wire shelf divider
- 3" Casters or 6" legs
- Low profile casters
- 4" Foamed-in-place backsplash (-FIP)
- Flat-top with no backsplash (-FLT)
- Remote option* (see note on back page)

REFRIGERATION SYSTEM

- Uses environmentally friendly, energy efficient R290 refrigerant, and meets all regulatory requirements for CARB, SNAP, DOE & more
- Adaptive defrost
- Refrigerator maintains product temperatures between 36°F and 38°F
- Freezer maintains product temperature from -10°F and below

WTRF48AHC DUAL TEMP WORKTOP



Please verify qualifying units by visiting:
www.energystar.gov/cfs

3779 Champion Blvd., Winston-Salem, NC 27105
1-888-845-9800 Fax: 1-336-245-6453
Beverage-Air.com Sales@bevair.com



BEVERAGE-AIR®

MODEL	WTRF48AHC
EXTERNAL DIMENSIONAL DATA	
Width Overall	48"
Depth Overall (with handle & bumper)	32"
Height Overall (with casters)	39 5/8"
Number of Doors	2
Depth with Door Extended	52 1/4"
Door Openings (in)	19 1/2" x 21 3/4"
INTERNAL DIMENSIONAL DATA	
NET Capacity (cubic ft.)	(R) 5.31 (F) 5.31
Internal Width Overall (in)	(2) 21"
Internal Depth Overall (in)	15 3/8"
Internal Height Overall (in)	23"
Number of Shelves	4
ELECTRICAL DATA	
Full Load Amperes 115/60/1	(R) 2.0 (F) 2.5
Voltage	(2) 115/60/1
Nema Plug (8' cord)	(2) 5-15P
REFRIGERATION DATA	
Horsepower	(R) 1/6 (F) 1/4
Capacity (BTU/Hr)	(R) 1110 (F) 857
Heat Rejection (BTU/Hr)	2950.5
Charge (lbs/grams/ounces)	(F) 0.0992 / 45 / 1.59 (R) 0.1323 / 60 / 2.12
SHIPPING DATA	
Gross Weight - Crated	314 lbs
Height - Crated	36"
Width - Crated	51"
Depth - Crated	32"

*NOTE: Remote units are field wired and come with 6" legs.
Refrigerant must be specified at time of order.

We reserve the right to change specifications and product design without notice. Such revisions do not entitle the buyer to corresponding changes, improvements, additions or replacements for previously purchased equipment. Dimensional tolerances +/- 1/4". Metric dimensions (MM).

Dual Temp Worktop Refrigerator/Freezer Model: WTRF48AHC

Model Views

Required Clearance: 3" Bottom & 2" Rear

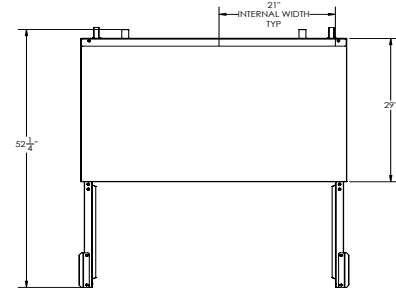

PLAN VIEW

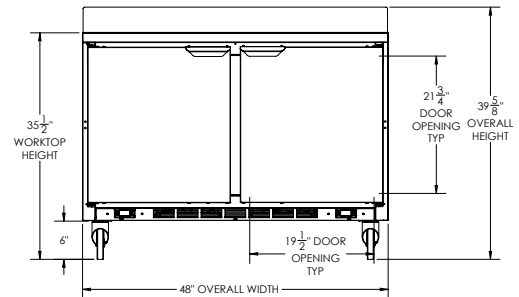

ELEVATION VIEW

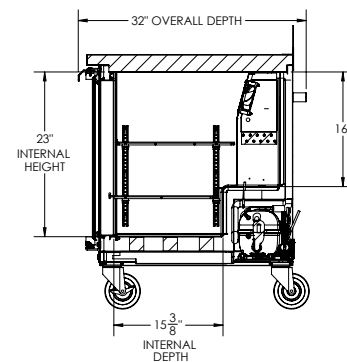

SIDE VIEW

ELECTRICAL CONNECTION



115/60/1
(2) NEMA 5-15P

Unit pre-wired at factory
and include (2) 8' long
cord and plug set.

