



Technical Data

Height with Lid Open	50 7/8 Inches
Interior Height	23 4/8 Inches
Work Surface Height	34 7/8 Inches
Amps	3.24
Hertz	60 Hertz
Phase	1 Phase
Voltage	115 Volts
1/6 Size Pan Capacity	15 Pans
1/9 Size Pan Capacity	/
Access Type	Doors
BTU (LBP)	1092 BTU
Capacity	7.6 cu.ft.
Casters	With Casters
Compressor Location	Rear Mounted
Compressor Style	Side / Rear Breathing
Construction	Stainless Steel and Aluminum
Door Style	Swing
Door Type	Solid
Features	Removable Magnetic Door Gaskets
Hinge Location	Left+Right
Horsepower	1/5 HP
Individual Shelf Capacity	88 lb.
Number of Doors	2 Doors
Number of Shelves	2 Shelf
Plug Type	NEMA 5-15P
Refrigerant Capacity	4.1 oz.
Refrigerant Type	R290
Refrigeration Type	Air Cooled
Temperature Range	33 - 41 Degrees F
Type	Prep Refrigeration



Plan View

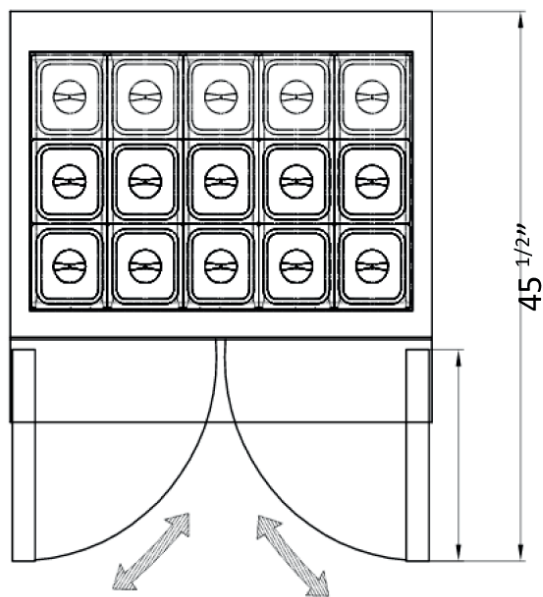
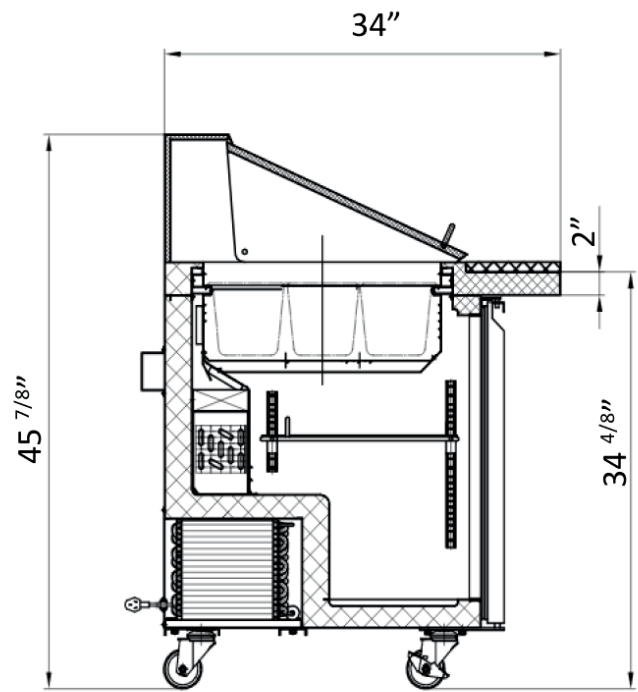
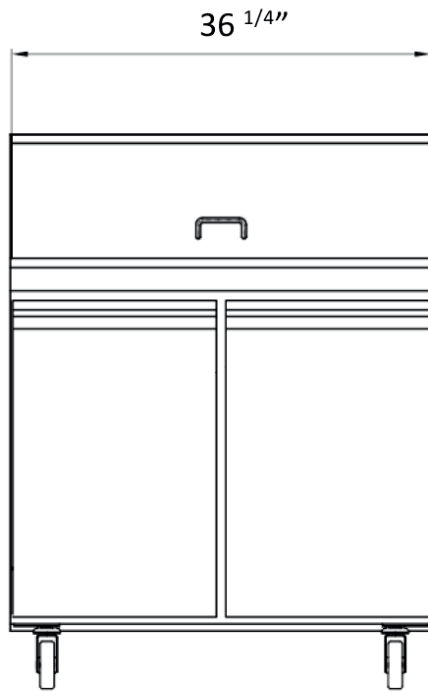



Notes & Details

This salad and sandwich prep table is meticulously crafted with a combination of stainless steel and aluminum, resulting in a robust structure that promises both durability and easy maintenance. The use of high-quality materials ensures longevity, making it an excellent investment for any commercial kitchen environment.

One of the standout features of this prep table is its advanced electronic control system, which allows for precise temperature adjustments. This level of control is crucial for maintaining food safety standards, ensuring that ingredients stay fresh and safe for consumption. Additionally, the electronic controls make it effortless to set and monitor the internal temperature, providing peace of mind to kitchen staff.

Moreover, the prep table is equipped with a rear-mounted compressor featuring side/rear breathing ventilation. This design enhances the efficiency of the cooling system, ensuring consistent and reliable performance even during prolonged use. The ventilation setup also contributes to the overall durability of the unit by promoting proper airflow and heat dissipation.

In terms of functionality, the prep table's compact design allows it to be used conveniently at countertop height. This makes it easy for kitchen staff to access ingredients and work efficiently during food preparation tasks. The inclusion of adjustable shelves further enhances its usability, allowing for customizable storage options based on the specific needs of the kitchen.

Energy efficiency is a key aspect of this prep table, consuming just 2 amps at 115 volts. This ensures cost-effective operation without compromising on performance. The air-cooled refrigeration system is designed to maintain a consistent temperature range between 33 and 40 degrees Fahrenheit, keeping ingredients optimally chilled without any fluctuations.

Overall, this salad and sandwich prep table combines cutting-edge features, durable construction, and user-friendly design elements to meet the demands of modern commercial kitchens. It's a versatile and reliable addition that enhances workflow efficiency while prioritizing food safety and freshness.

ETL Sanitation



This product has been certified by ETL, a division of the Intertek Group, to meet applicable sanitation standards required for use in the United States and Canada.

5-15P



This unit comes with a NEMA 5-15P plug

ETL, US



This product has been certified by ETL, a division of the Intertek Group, to meet applicable electrical product safety standards required for use in the United States.