



Profit from the Eagle Advantage®

Specification Sheet

Short Form Specifications

Eagle Chopping Table, model _____. Top to be 1½" square stainless steel tubular frame all-welded with two layers of ½" thick removable polymer. Unit to conform to USDA and NSF requirements. 1½" O.D. stainless steel tubular legs with stainless steel crossrails, and adjustable bullet feet.



chopping table

Options / Accessories

- Casters*
- Stainless steel bullet feet
- Undershelf **
- All-welded construction ***
- Boat rack
- Drawer assemblies**** / Drawer support angles ****

* For optional 4" resilient-tread casters, add suffix "-CA". Example: CHT3030S-CA
For optional 5" resilient-tread casters, add suffix "-CAH". Example: CHT2448S-CAH

** For optional stainless steel undershelf, add suffix "-US". Example: CHT3048S-US

*** For optional all-welded construction, add suffix "-AW". Example: CHT2436S-AWZ

**** See spec sheet #EG10.13 for Drawer Assemblies available.

For optional Drawer Assemblies, Drawer Support Angles are required:

- For 24"-wide tables with flat top, order model #609542 drawer supports.
- For 24"-wide tables with backsplash, order model #609541 drawer supports.
- For 30"-wide tables with flat top, order model #609540 drawer supports.
- For 30"-wide tables with backsplash, order model #609539 drawer supports.

EAGLE GROUP

100 Industrial Boulevard, Clayton, DE 19938-8903 USA

Phone: 302-653-3000 • Fax: 302-653-2065

www.eaglegrp.com

Foodservice Division: Phone 800-441-8440

MHC/Retail Display Divisions: Phone 800-637-5100

For custom configuration or fabrication needs, contact our SpecFAB® Division.

Phone: 302-653-3000 • Fax: 302-653-2065 • e-mail: quotes@eaglegrp.com

Item No.:	_____
Project No.:	_____
S.I.S. No.:	_____

Chopping Tables

MODELS:

- CHT2424S
- CHT2430S
- CHT2436S
- CHT2448S
- CHT3030S
- CHT3036S
- CHT3048S

Tabletop

- Double-thick poly top, 1" (25mm) total thickness.
- 1½" (38mm) square stainless steel tubular frame.
- Tabs, along perimeter of tabletop frame, lock poly top in place and are virtually self-cleaning.

Crossbracing

- Heavy gauge stainless steel.
- 1¼" (32mm)-diameter.
- Adjustable.
- Runs left-to-right at rear and front-to-back at both ends.

Legs

- Heavy gauge stainless steel.
- 1½" (41mm)-diameter.
- Adjustable metal feet.

Certifications / Approvals



EG10.11 Rev. 01/17

Spec sheets available for viewing, printing or downloading from our online literature library at www.eaglegrp.com

Eagle Foodservice Equipment, Eagle MHC, SpecFAB®, and Retail Display are divisions of Eagle Group. ©2017 by the Eagle Group



Item No.: _____
 Project No.: _____
 S.I.S. No.: _____

Chopping Tables

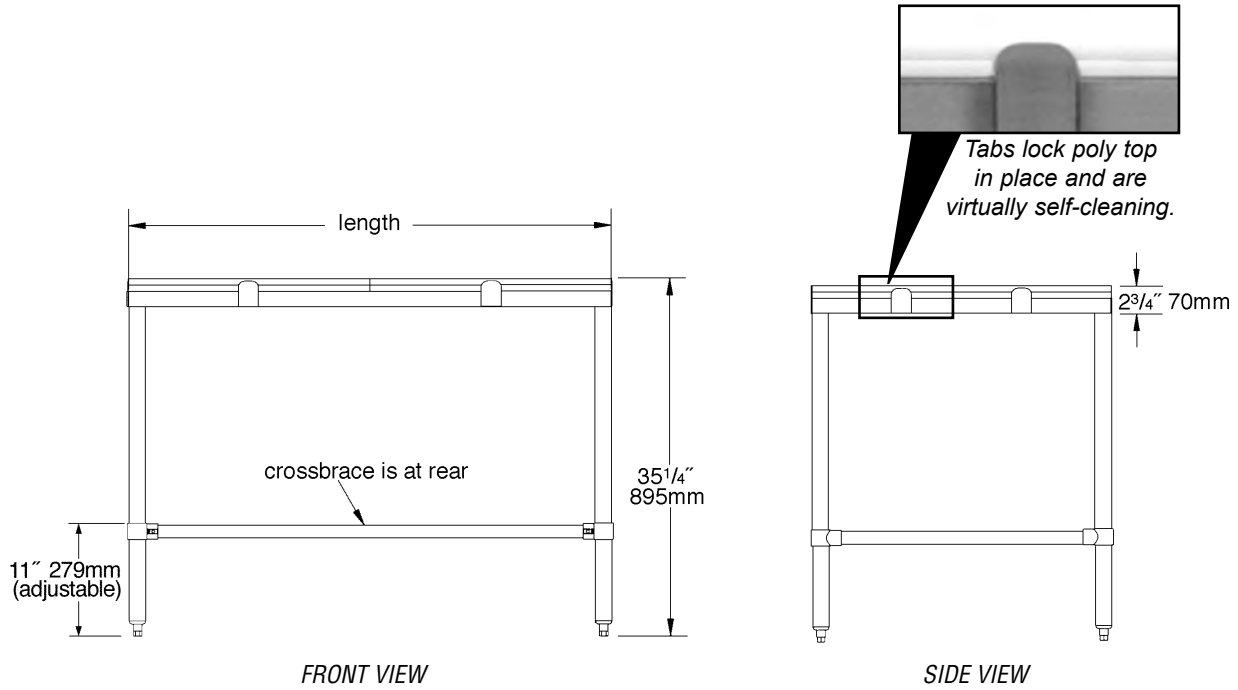

model #	width		length		weight	
	in.	mm	in.	mm	lbs.	kg
CHT2424S	24"	610	24"	610	110	49.9
CHT2430S	24"	610	30"	762	118	53.5
CHT2436S	24"	610	36"	914	126	57.2
CHT2448S	24"	610	48"	1219	142	64.4
CHT3030S	30"	762	30"	762	126	57.2
CHT3036S	30"	762	36"	914	134	60.8
CHT3048S	30"	762	48"	1219	150	68.0

EAGLE GROUP
 100 Industrial Boulevard, Clayton, DE 19938-8903 USA
 Phone: 302-653-3000 • Fax: 302-653-2065
 www.eaglegrp.com

Foodservice Division: Phone 800-441-8440
 MHC/Retail Display Divisions: Phone 800-637-5100

Printed in U.S.A.
 ©2017 by Eagle Group
 Rev. 01/17

Spec sheets available for viewing, printing or downloading from our online literature library at www.eaglegrp.com

Although every attempt has been made to ensure the accuracy of the information provided, we cannot be held responsible for typographical or printing errors. Information and specifications are subject to change without notice. Please confirm at time of order.