



## 36" Two Door Refrigerated Prep Table – 9 cu. ft. (254.8 L) Capacity

ITEM: 50034

MODEL: PT-CN-0920-HC

**Omcan Refrigerated Sandwich/Salad Prep Table helps you create your signature sandwiches and salads quickly and easily.**

This refrigerated prep table line boasts a spacious working area, allowing for extra ingredient storage. Plus, it's environmentally friendly and energy-efficient thanks to the Hydro-Carbon R290 refrigerant it uses. High-quality stainless steel construction provides durability and longevity and guarantees maximum hygiene and food-grade standards.



### FEATURES:

- ✓ Stainless steel interior and exterior, aluminum back
- ✓ Refrigeration system keeps food at safe temperatures between 33°F and 40°F (0.5°C to 4.4°C).
- ✓ Self-closing doors with 90 degree stay-open feature
- ✓ Adjustable heavy-duty PVC coated shelves
- ✓ 10 mm cutting board thickness
- ✓ Adjustable heavy-duty PVC coated shelves
- ✓ Uses Hydro-Carbon R290 refrigerant which is environmentally friendly and more efficient

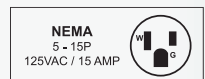
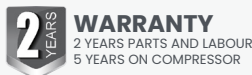

## TECHNICAL DRAWING

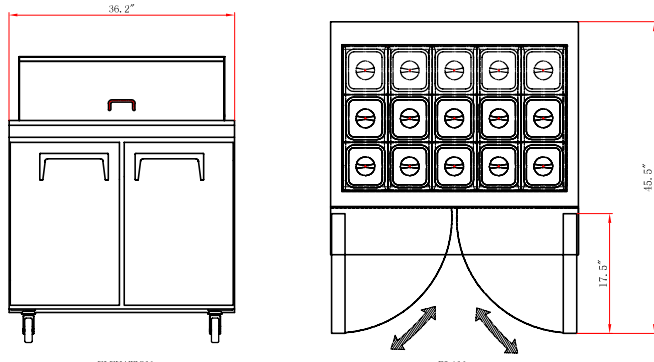

ELEVATION

Front

PLAN

Back

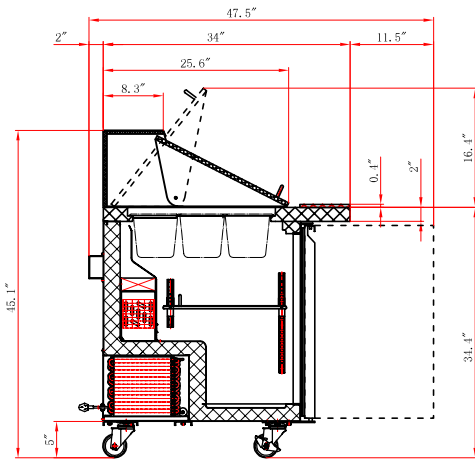

SECTION VIEW

Side

## TECHNICAL SPECIFICATION

Item	50034
Model	PT-CN-0920-HC
Capacity	9 cu. ft. (254.8 L)
Temperature Range	0.5°C - 4.4°C (33°F - 40°F)
Max Ambient Temperature Rating	24°C (75°F)
Refrigerant	R290
Electrical	115V / 60Hz / 1Ph
Power	319.5W
Amps	4.3A
Insulation Material	Cyclopentane
Cooling System	Ventilated
Defrosting	Automatic
Number of Door	2
Number of Shelves	2
Shelf Loading Capacity	88 lbs (39.9 kg)
Net Dimensions	36.2" x 29.5" x 41.5" (920 x 750 x 1055 mm)
Net Weight	220.5 lbs. (100 kg)
Gross Dimensions	41.3" x 34.6" x 45.7" (1049 x 878 x 1160 mm)
Gross Weight	286.6 lbs. (129.9 kg)

\* This equipment is intended for indoor environment using where ambient temperature does not exceed 24°C (75°F) & 55% relative humidity.