

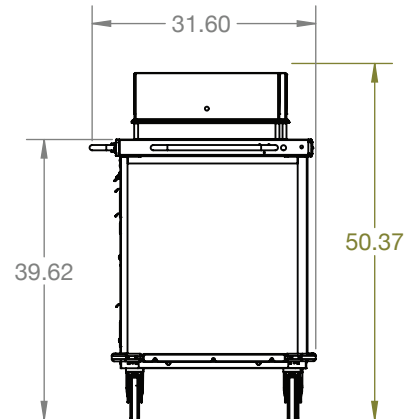

Four Bay Heated Foodservice Cart

Model: CBC-HHHH

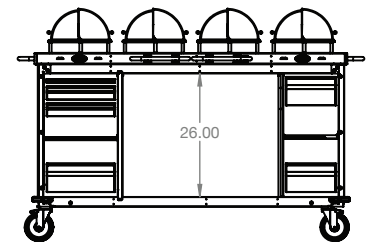
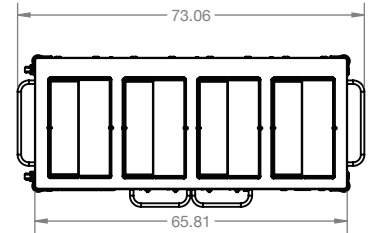

Product Features

- Stainless Steel construction with handles
- Silent casters (2 with locking brakes; 2 with directional locks)
- Laminate finish or stainless steel panels on front/sides of cart
- 4 full size HOT buffet servers: each has 2 half size stainless steam pans, 1 clear Eastman Tritan copolyester rolltop lid with metal hinges & stainless pan holder
- 2 ½" deep half-size pans hold over (30) 4 oz. servings ea.
- 6 drawers: plating drawer, silverware storage, divided/condiments storage, & cold storage
- 2 shelves (1 for tray storage)
- (2) 9.4 qt clear polycarbonate pans, each with Cambro #20PPD drain shelf
- 4 variable heat control knobs (-155° - 205°F)
- 72" long coiled cord
- 120 v / 1200w / 10 amps
- Rubber bumpers on top and bottom of cart corners
- Warming surface top removable for service
- Space for optional Cambro Camcarrier Hot/Cold Box, Model UPC 400 or UPCH 400 or equivalent
- Freight class 250: Not UPS-able, must ship by truck
- All carts FOB factory (06098)
- Warranty: 1 year limited warranty in contiguous US states. 30 days initial defect on laminate panels

Freight Class: 250.

Not UPS-able, must ship by truck. F.O.B. 06098. *Ship weights include shipping skids (approx. 40 lbs. per skid)



www.cadco-ltd.com



860.738.2500



info@cadco-ltd.com