



Technical Data

| | |
|---------------------------|---|
| Hertz | 60 Hertz |
| Phase | 1 Phase |
| Voltage | 115 Volts |
| Access Type | Doors |
| BTU (LBP) | 1739 BTU |
| Capacity | 14.1 cu.ft. |
| Compressor Location | Rear Mounted |
| Compressor Style | LMBP |
| Door Style | Swing |
| Door Type | Solid / Left & Right |
| Features | Removable Magnetic Door Gaskets Self-Closing Doors |
| Horsepower | 1/4 HP |
| Individual Shelf Capacity | 66 lb. |
| Number of Doors | 2 Door |
| Number of Shelves | 2 Shelf |
| Plug Type | NEMA 5-15P |
| Refrigerant Capacity | 2.12 oz. |
| Refrigerant Type | R-290 |
| Style | Counter Height |
| Temperature Range | -8 ~ 0 Degrees F |
| Type | Freezers Undercounter Freezers |



Plan View

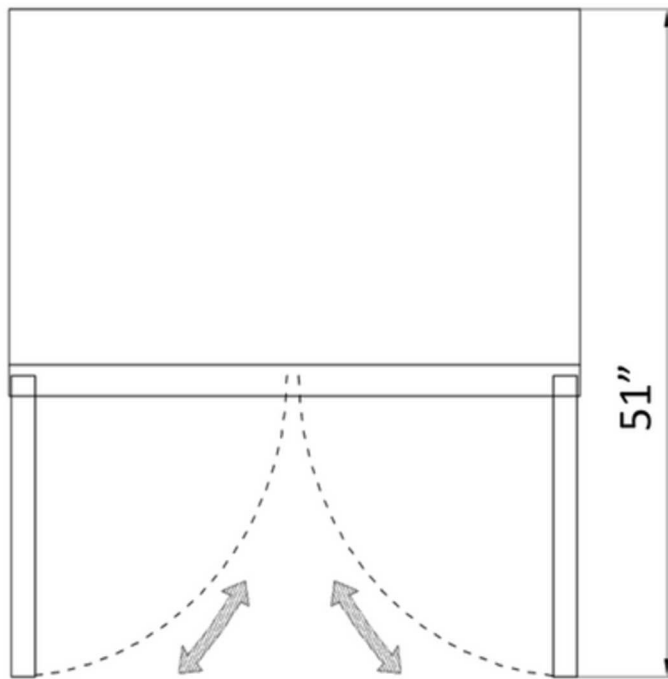
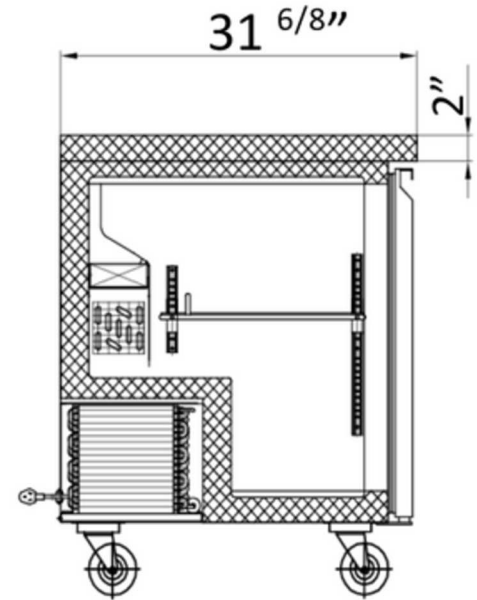
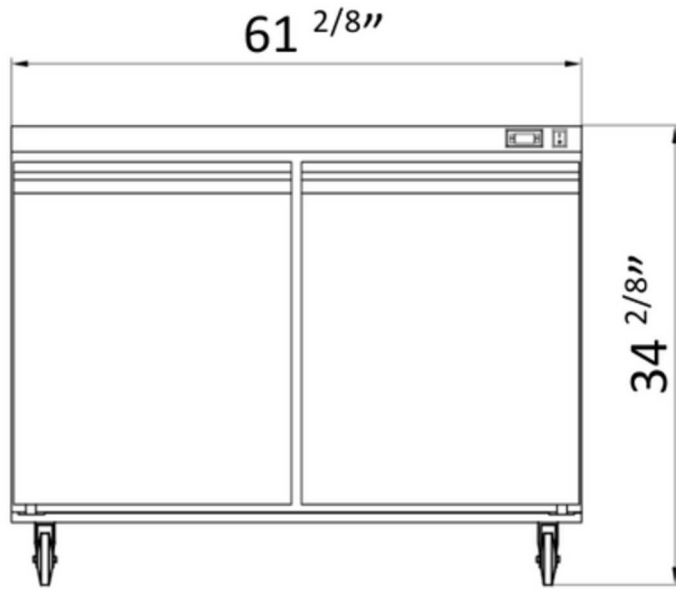



Notes & Details

The HKN-UC60F2D Undercounter Freezer is a space-saving powerhouse, ideal for commercial kitchens seeking to maximize storage without sacrificing valuable workspace. Its sleek undercounter design provides easy access to frozen ingredients, enhancing kitchen workflow and efficiency while integrating seamlessly into compact layouts.

Inside, the freezer offers a generous storage area with ample width, depth, and height to keep items organized and easily accessible. The right door's wide opening allows convenient access, while adjustable shelves offer the flexibility to store items of various sizes, making the most of every inch.

The work surface height is optimized for use as an additional prep space, providing dual functionality in busy kitchen environments. Constructed from durable stainless steel, this freezer is built to withstand daily wear and tear and is easy to clean, ensuring long-lasting use.

Powered by an efficient system, the freezer offers reliable performance while operating with eco-friendly R290 refrigerant, which helps reduce environmental impact. The extended power cord also provides flexibility in placement within the kitchen setup.

In essence, the HKN-UC60F2D Undercounter Freezer is a thoughtfully designed solution for any high-demand kitchen, offering durability, efficiency, and sustainability in one compact unit. Its user-friendly layout, optimized storage, and seamless integration make it an invaluable asset for professional kitchen setups.

ETL Sanitation



This product has been certified by ETL, a division of the Intertek Group, to meet applicable sanitation standards required for use in the United States and Canada.

5-15P



This unit comes with a NEMA 5-15P plug

ETL, US



This product has been certified by ETL, a division of the Intertek Group, to meet applicable electrical product safety standards required for use in the United States.