



YOU CAN TRUST

FOOD BLENDERS

LAR-4MBSE / LAR-6MBSE
LAR-8MBSE / LAR-10MBSE



STANDARD FEATURES

SKYFOOD's table top Food Blenders are perfect for small and medium kitchen operations. Four different capacities are available to best suit your needs.

All models are equipped with a powerful 1/2 HP motor and four stainless steel blades positioned close to the bottom and sides of the container to create a perfect vortex and optimize results.

Stainless steel seamless container with four pressed internal ribs and stainless steel base ensure proper mixing and easy cleaning.

Robust square base provides great stability.

All metal coupling system designed to last.

Running at 3500 rpm these low rotation Food Blenders are perfect for making salsa and other recipes with cold or hot ingredients up to 140 F [60 C].

No-spill rubber cover with filler-cap allows for adding more ingredients during operation.

Conform to the following standards: UL electrical and sanitation (under UL, CSA and NSF standards).

IDEAL FOR MAKING:

- Sauces and Creams
- Crepe Dough
- Mayonnaise
- Potato Soup and Similar Recipes with Cooked Vegetables
- Creamy or Liquid Soups
- Fresh Fruit Juices
(little fruit pieces may be present in final product)



LAR-4MBSE
Food Blender



LAR-6MBSE
Food Blender



LAR-8MBSE
Food Blender



LAR-10MBSE
Food Blender

ILLUSTRATIVE PHOTO, ACTUAL PRODUCTS AND ACCESSORIES ARE SUBJECT TO CHANGE WITHOUT NOTICE



Skyfood Equipment LLC
175 SW 7th Street, Ste 2416
Miami, FL 33130

Toll Free:
1-800-503-7534
sales@skyfood.us

www.skyfood.us



Follow us to keep up to date with the later news and offers

/SkyfoodEquipment

/SkyfoodEquipment

/SkyfoodEquipment



YOU CAN TRUST

FOOD BLENDERS

LAR-4MBSE / LAR-6MBSE
LAR-8MBSE / LAR-10MBSE



DIMENSIONS

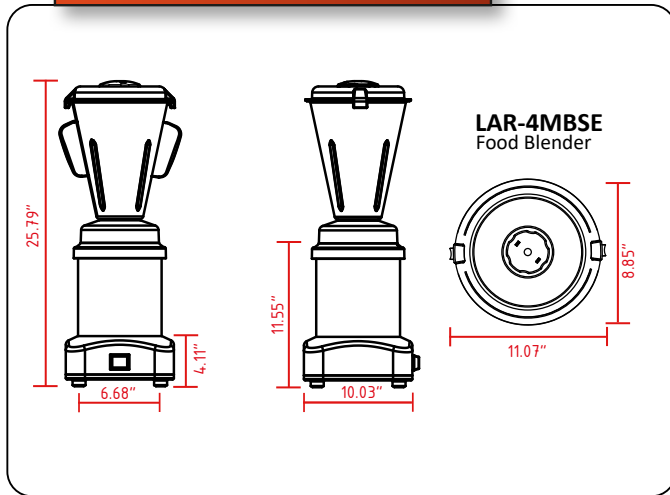

DIMENSIONS

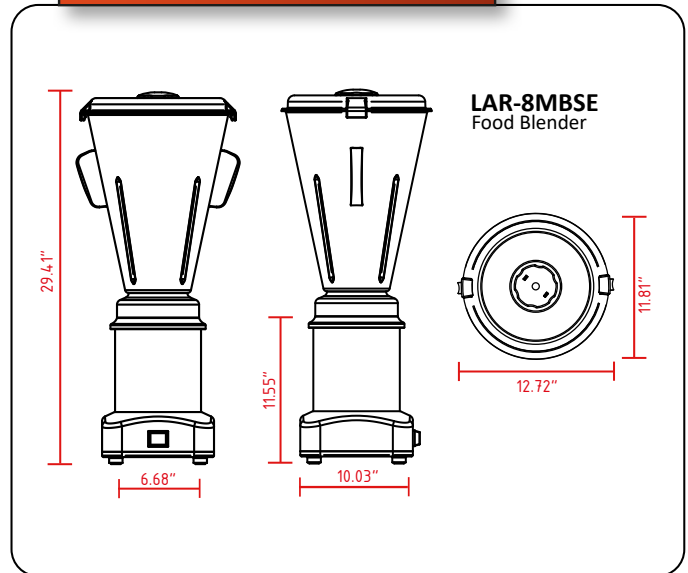

DIMENSIONS

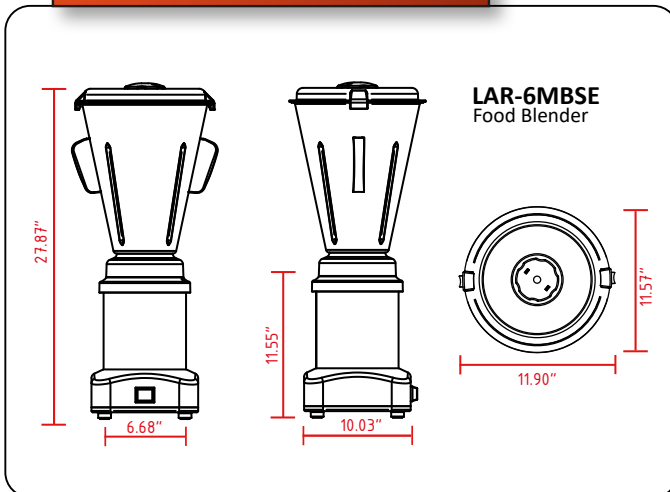

DIMENSIONS

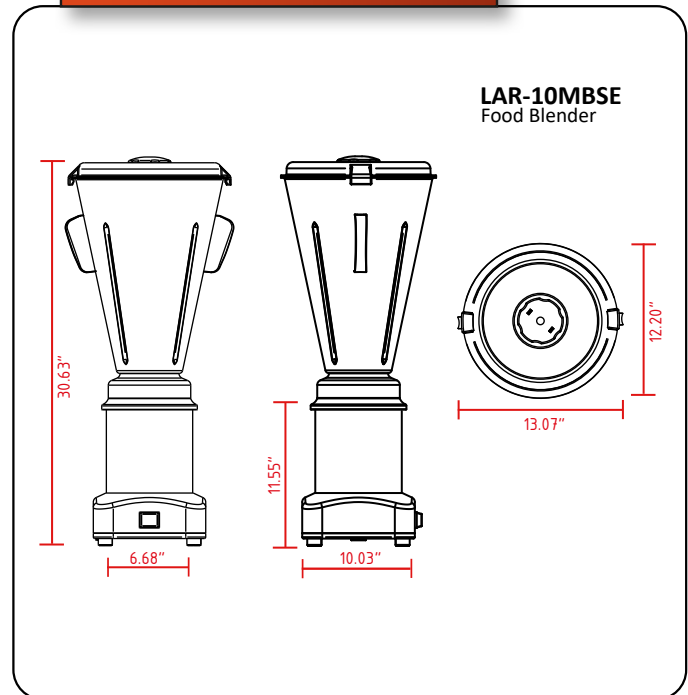

PLUG
NEMA 5-15P



COMMERCIAL BLENDERS
E505079



NSF/ANSI 2
COMMERCIAL BLENDERS
E505080

WARRANTY 01 YEAR PARTS AND LABOR VALID IN THE CONTINENTAL UNITED STATES.



MADE IN BRAZIL

Item	Voltage	AMPS	Power Rating	Dimensions (W x D x H)	Weight (Net x Ship)	Capacity	RPM	PLUG
LAR-4MBSE	115 V	11.4	1 1/2 HP	11.07" x 10.03" x 25.79"	19.2 lb x 28.9 lb	1 gal	3.500	NEMA 5-15P
LAR-6MBSE	115 V	11.4	1 1/2 HP	11.90" x 11.57" x 27.87"	19.6 lb x 29.7 lb	1 1/2 gal	3.500	NEMA 5-15P
LAR-8MBSE	115 V	11.4	1 1/2 HP	12.72" x 11.81" x 29.41"	21.8 lb x 32.6 lb	2 gal	3.500	NEMA 5-15P
LAR-10MBSE	115 V	11.4	1 1/2 HP	13.07" x 12.20" x 30.63"	22.7 lb x 34.1 lb	2 1/2 gal	3.500	NEMA 5-15P

ILLUSTRATIVE PHOTO, ACTUAL PRODUCTS AND ACCESSORIES ARE SUBJECT TO CHANGE WITHOUT NOTICE



Skyfood Equipment LLC
175 SW 7th Street, Ste 2416
Miami, FL 33130

Toll Free:
1-800-503-7534
sales@skyfood.us

www.skyfood.us



Follow us to keep up to date with the later news and offers

[/SkyfoodEquipment](#)

[/SkyfoodEquipment](#)

[/SkyfoodEquipment](#)