



Features

Eco-Friendly Refrigerant

R290 refrigerant with a global warming potential (GWP) of 3

High-Strength, Full-Extension Drawers

Premium slide and framework construction promotes lateral stability while offering high dynamic load capacities and a stay-shut feature

Stainless Steel Exterior

Galvanized back and bottom to reduce the risk of corrosion

Long-Lasting, Removable Gaskets

Santorprene™ gaskets last four times longer than standard gaskets

Heavy-Duty Soft Casters

Secured to a 12 gauge steel base to ensure years of worry-free operation

High-Efficiency Refrigeration System

Forced air circulation provides uniform temperature throughout the cabinet

Drawer Capacity

Large drawers include two (2) divider bars to accommodate three (3) full-size 12"W x 20"H x 6"D hotel pans. Small drawers include one (1) divider bar to accommodate two (2) full-size hotel pans — additional pan adapters are available for fractional pans.

Easy to Clean

Aluminum interior, coved corners, finished edges, plus full-extension and easy lift out drawers

High-Density Insulation

Foamed-in-place, CFC-free polyurethane insulation for maximum strength, rigidity, and insulation

Flat Top with Corner Brackets

Corner brackets assist in preventing movement of cooking equipment — includes top handles for mobility

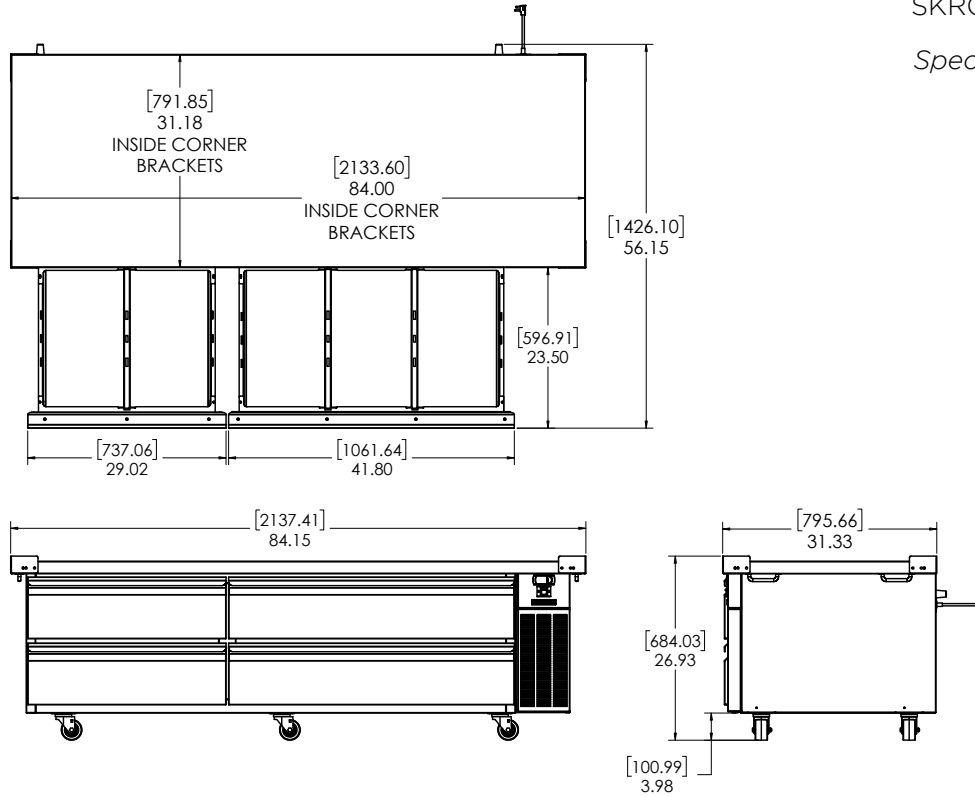

Technical Specifications

Electrical Requirements	115v/60hz/1ph/2.3A/NEMA 5-15P Plug
Product Dimensions	84"W x 26.47"H x 32.58"D (213.36cm x 67.23cm x 82.75cm)
Product Weight	530lbs (240.40kg)
Shipping Dimensions	89"W x 31"H x 36"D (226.06cm x 78.74cm x 91.44cm)
Shipping Weight	540lbs (244.94kg)
Shipping Cubic Dimensions	57.48ft ³ (1.63m ³)
Temperature Range	36 to 40°F (2.2 to 4.4°C)
Refrigerant	R290
Insulation	CFC-free polyurethane foam-in-place insulation

Exterior Construction	Stainless steel exterior with galvanized back and bottom
Interior Construction	Aluminum interior with coved corners and finished edges
Drawers	Four (4) high-strength, full-extension drawers with dividers
Capacity	Ten (10) full-size 12"W x 20"H x 6"D hotel pans
Door/Drawer Gasket	Santoprene™ gasket
Casters	Six (6) 4" heavy-duty soft casters (three locking)
Certifications	ETL Safety, ETL Sanitation
Warranty	1-year parts and labor, 5-year compressor (part only)

Model Number	Description
SKRCB84H-EDUS4	Chef Base Refrigerator 84", 115v/6hz/1ph/2.3A, flat top with corner brackets and top handles, 4 drawer, 4" heavy-duty soft casters, C13/NEMA 5-5P

Accessories	Description
25567	Adapter Bars for Fractional Pans
43581	Pan 1/6 Size, 4" Deep Plastic
43643	Pan 1/6 Size, 6" Deep Plastic
27066	Pan 1/3 Size, 4" Deep Plastic
26415	Pan 1/3 Size, 6" Deep Plastic

To learn more about **Silver King Chef Base Refrigerator**, visit silverking.com