



AMERICAN EAGLE[®]
FOOD MACHINERY, INC.

AE-125K
250 Quart
Fixed Bowl Spiral Mixers

773.376.0800 (P) • 773.376.2010 (F) • 3131 S. Canal St. Chicago, IL 60616

Spiral Mixing Technology ***The Secret to Better Dough!***

American Eagle® Spiral Mixers Provide Coordinated Movement Of Bowl And Agitator To Keep Dough Cool While Mixing For Consistent Texture. The Large Fixed Bowl Designs Are The Perfect Size For Smaller Industrial Dough Mixing Operations!

Quality Design

- Dual Motor System Separates Bowl And Agitator Loads
- Heavy Duty, Unimold Cast Iron Construction
- Multiple V-belt Drive With Embedded Fibers For Extra Strength
- Motor Start-Up Relay System Reduces Torque Stress On Belts
- ETL Certified To NSF No. 8, CSA, CE Standards
- NSF Approved Enamel Coating Resists Scratches, Dents, And Rust

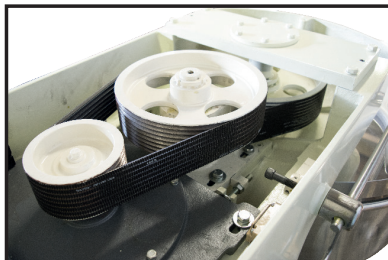

**Efficient Dual
 Flywheel
 V-Belt Drive
 System**

**Reliable
 Electronics
 For Superior
 Service Life**



Standard Features

- Dual 30 Minute Timers Automatically Switch Between Low And High Speed
- 3 Mode Reversible Mixing Bowl (Stop, Clockwise, and Counter-Clockwise)
- Thermal Overload Protection
- Safety Guard With Auto-Shutoff
- Guard Opening For Adding Ingredients While Mixing
- 1 Year Limited Warranty*
- Heavy Duty, 7 Foot, Four Wire Power Cable*

Other Available Sizes

- AE-3050 80 Quart, 110 lbs Dough, 66 lbs Flour
- AE-5080 125 Quart, 176 lbs Dough, 100 lbs Flour
- AE-100K 220 Quart, 330 lbs Dough, 220 lbs Flour (Special Order Item)

Proud Member of:

 North American Association of
 Food Equipment Manufacturers

Quality • Value • Reliability



AMERICAN EAGLE[®]
FOOD MACHINERY, INC.

AE-125K
250 Quart
Fixed Bowl Spiral Mixers

sales@ameagle.biz • www.americaneaglemachine.com

Lower Your Total Cost Of Ownership With American Eagle® Spiral Mixers! Quality Design, Competitive Pricing, And Reliable Support Make Us The Value Leader In The Industry.

Specifications

Model	Capacity**	Motor	Voltage V/HZ/PH	Amps	Transmission	Agitator Speeds (RPMs)	Safety Guard ^A	Timer
AE-125K	250 Quarts Max 275 lbs flour Max 396 lbs dough	15 HP Agitator 5 HP Bowl	220 / 60 / 3	38-43 Agitator 13.9 Bowl	Belt Driven	Low: 131 High: 262	Yes	Dual 30 min (60 min total)

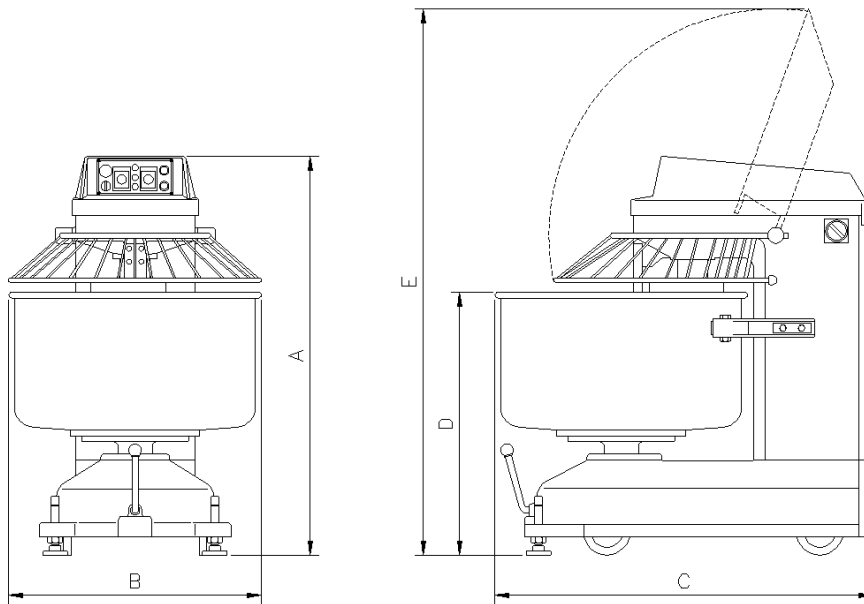

Line drawing is referenced for dimensions, current product may vary due to cosmetic design changes

Measurements

Dimension	Inches	Centimeters
A	59.1	150
B	37.4	95
C	61	155
D	38.6	98
E	86.6	220

Dimensions and Shipping Information

Model	Overall Dimensions (w/Guard Raised)	Foot Print	Net Weight	Shipping Dimensions***	Ship Weight	Freight Class
AE-125K**	37.4"W x 61"L x 59.1" (86.6") H	61" W x 37" L	2205 lbs (1000 kg)	40"W x 83.5"L x 69"H	2940 (1334 kg)	85

^ASafety guard can be upgraded to stainless steel wire style at additional cost

* Warranty must be registered, Improper wiring to plug and electrical service will void warranty, improper installation voids warranty. Extended Warranty available at extra cost.

** Capacity will be diminished depending on dough density, rated capacities are for typical bread dough. Overloading will void warranty

*** Crates are affixed to a skid (pallet). The weight and dimensions of this skid are included above and may vary



Quality • Value • Reliability