



COMPETITOR SERIES®

PROJECT: _____
 LOCATION: _____
 ITEM#: _____
 QUANTITY: _____



C-HCT27



C-HCT34



C-HCT47

HEATED COUNTER-TOP DISPLAY CASES, STRAIGHT GLASS, REAR SLIDING DOORS

- Beautiful ergonomic construction
- Dial temperature controller with digital temperature read-out
- All stainless steel interior & exterior front, glass covered black sides
- Glass front, sides and top
- Sliding glass doors in the rear to access the food products
- Maintains temperatures between 86°F to 194°F
- LED interior lighting
- Removable water pan to add humidity to interior
- Cantilever, chrome epoxy-plated shelves
- Migali® Protection Plan: 2 Year Parts & Labor Warranty, 5 Year Compressor Warranty

MODEL	DOORS	SHELVES	CAPACITY CU/FT	AMPS	ENERGY CONSUMPTION KWH/24 HR	PLUG TYPE	TEMP RANGE	EXTERIOR DIMENSIONS W X D X H**	INTERIOR DIMENSIONS W X D X H	PACKAGED DIMENSIONS W X D X H**	WEIGHT	PACKAGED WEIGHT
C-HCT27	Sliding	2	4.5	9.5		Nema 5-15P	+86°F (~) +194°F	26.6 x 23 x 27	26.1 x 20.9 x 18.9	28.94 x 25 x 28.35	76 lbs.	81.5 lbs.
C-HCT34	Sliding	2	5.6	12.6		Nema 5-15P	+86°F (~) +194°F	33.7 x 23 x 27	33.1 x 20.9 x 18.9	35.94 x 25 x 28.35	93.6 lbs.	99.2 lbs.
C-HCT47	Sliding	2	7	12.6		Nema 5-15P	+86°F (~) +194°F	47.1 x 23 x 27	46.5 x 20.9 x 18.9	49.21 x 25 x 28.35	120.1 lbs.	127.8 lbs.

FOR COMMERCIAL USE ONLY

NOTE: MIGALI® RESERVES THE RIGHT TO CHANGE SPECIFICATIONS WITHOUT NOTICE



TOLL FREE: 800.852.5292
 WEB: www.migali.com



DIMENSIONAL DRAWINGS

C-HCT27

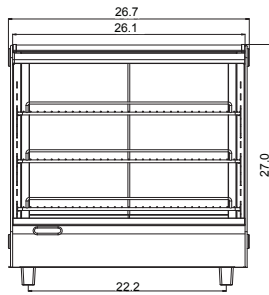

C-HCT34

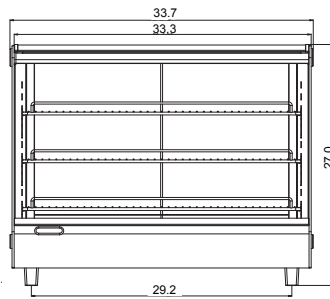

C-HCT47

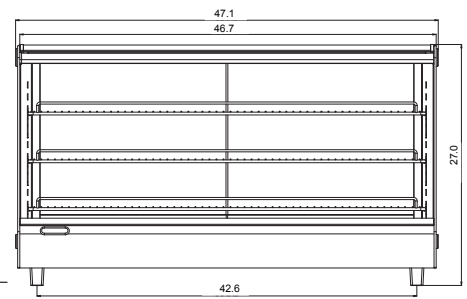

**C-HCT27
BACK VIEW**

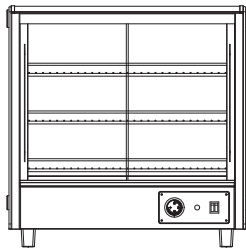

**C-HCT34
BACK VIEW**

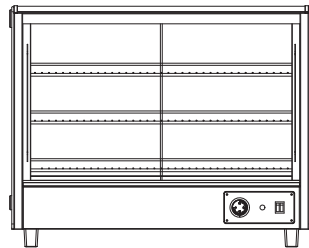

**C-HCT47
BACK VIEW**

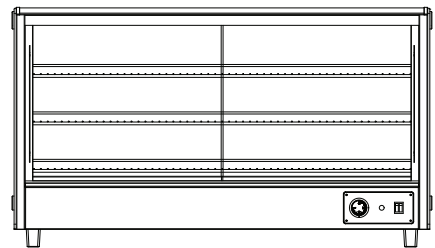

**C-HCT27
TOP VIEW**

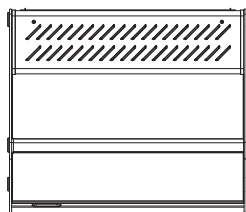

**C-HCT34
TOP VIEW**

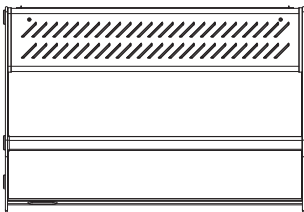

**C-HCT47
TOP VIEW**

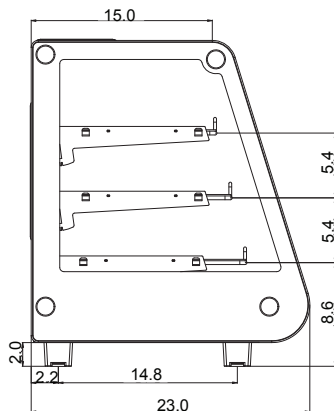
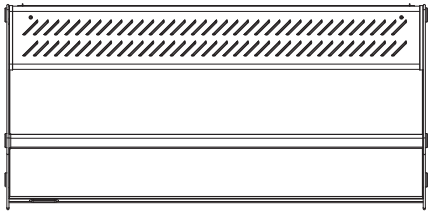

SIDE VIEW



MIGALI® REMAINS AN AMERICAN FAMILY COMPANY SINCE 1955