

GRIDDLE STAND FREEZER (0°F)

Model: D84GFN

Natural Refrigerant R-290 Model

84" Griddle Stand Freezer



ENERGY STAR® Qualified Commercial Freezer

Stainless steel exterior and interior, reinforced stainless steel work top with drip guard marine edge and stainless steel case back.



Options and Accessories

(upcharge and lead times may apply)

Flat top in lieu of marine edge	Integral heat shield top
16 gauge stainless steel top (flat or marine)	Cylinder locks
Top extensions (flat or marine edge)	Doors in lieu of drawers
Condensing unit on left (standard on right)	Special electrical requirements (consult factory)

Consult factory for other model configurations, options and accessories.

Project Name:

Model Specified:

Location:

Item No:

Quantity:

AIA #:

SIS #:

Standard Model Features

REFRIGERATION SYSTEM

- Performance rated refrigeration system
- Natural, environmentally safe, high efficiency R-290 refrigerant¹
- Automatic, hot gas condensate evaporator
- Non-corrosive, plasticized fin evaporator coil
- Expansion valve system
- Easily serviceable, front slide outcondensing unit

CABINET ARCHITECTURE

- High density, non-CFC polyurethane foamed-in-place insulation
- Easy glide, fully extendable drawers designed to hold 6" deep pans side-by-side
- Smooth, polished chrome drawer handles
- One-piece, snap in magnetic Santoprene™ drawer gaskets
- Heavy duty drawer track with built in drawer safety clips
- Drawers designed to hold 250 lb. capacity
- (4) drawer pan divider bars*
- 4" casters on support plates

* Pans supplied by others

MODEL FEATURES

- Electronic control, automatic electric defrost
- Front breathing

¹ R-290 refrigerant meets all federal and state regulatory requirements.



APPROVAL:

Model Specifications

DIMENSIONAL DATA

Net Capacity (cubic feet)	20.0 (566 cu l)
Width, Overall (inches)	84 (2134 mm)
Depth, Overall (inches) (including handles)	35 5/16 (897 mm)
Height, Overall (inches) (including 4" casters)	26 3/8 (670 mm)
Number of Drawers	4

REFRIGERANT DATA

Condensing Unit Size (H.P.)	1/2
Capacity (BTU per hour)*	2470

* Rating @ -15°F evaporator, 90°F ambient

ELECTRICAL DATA

Voltage (International)	115/60/1 (220/50/1)
Feed Wires (including ground)	3
Total Amps (International)	7.3 (4.9)
Defrost Amps (International)	7.4 (5.0)
10 ft. Cord/Plug [attached] (International)	Yes (No)

SHIPPING DATA

Weight (pounds)	640 (290 kg)
Height - Crated (inches)	30 (762 mm)
Width - Crated (inches)	109 (2769 mm)
Depth - Crated (inches)	39 (991 mm)

DRAWER PAN DIVIDERS (supplied with model)

CM2-0764 4 (one per drawer)

See drawer pan configurations on right (**pans not supplied**). For other drawer pan configurations, consult factory.

TOP WEIGHT CAPACITY

Max. Top Weight Capacity (pounds) 1400 (635 kg)

Figures in parentheses reflect metric equivalents rounded to the nearest whole unit.



Equipped with one NEMA-5-15P Plug
(varies by country)

Continental
Refrigerator

Toll-Free: 800-523-7138
Phone: 215-244-1400
Fax: 215-244-9579

539 Dunksferry Road
Bensalem, PA 19020
www.continentalrefrigerator.com

Due to our continued efforts in developing innovative products, specifications subject to change without notice.



PROUDLY
DESIGNED & ASSEMBLED
IN THE U.S.A.

© Copyright 2021. Continental Refrigerator.
A Division of National Refrigeration & Air Conditioning Products, Inc.

Model Plan Views

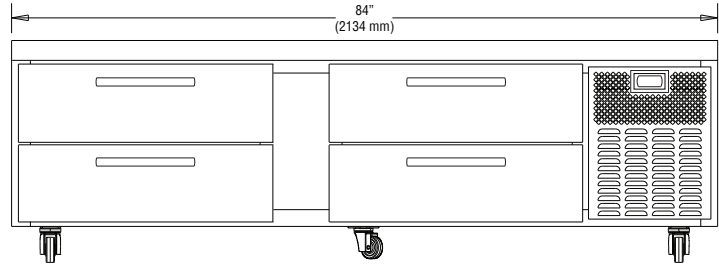

FRONT VIEW

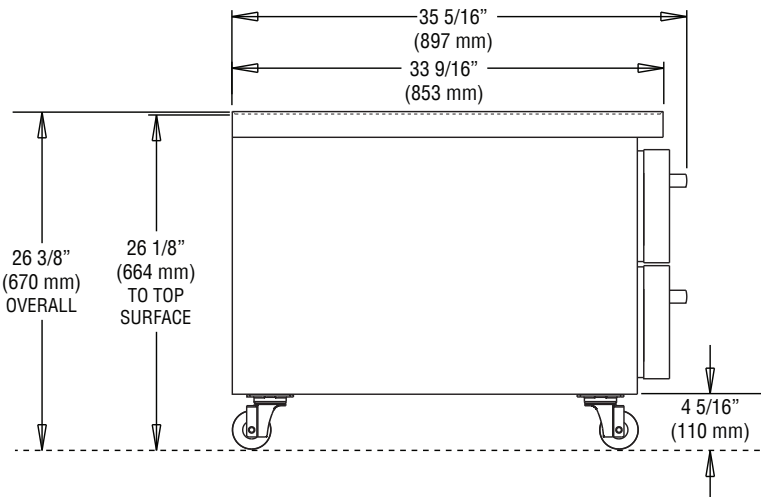

SIDE VIEW

Shown with (8) 12 x 20 x 6 pans (**not supplied**).

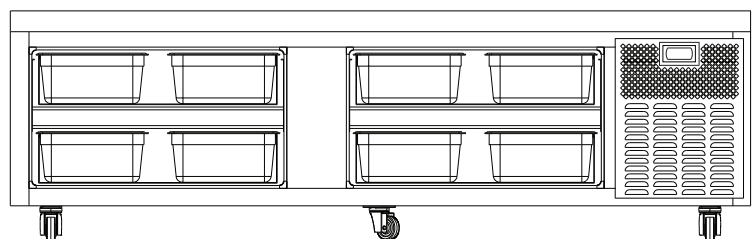

DRAWER PAN CONFIGURATION

REVISED:2/9/24