



U-Star's mega top salad/sandwich prep tables are constructed of heavy duty stainless steel both inside and out making them strong and durable enough to survive in any kitchen environment. Store all of your condiments, meats and vegetables in the cold topping area that can hold a variety of different sized food pans up to 6" deep. The oversized hinged insulated cover keeps the food items cold when not in service. Store additional items below in the cabinet for quick access when needed. All salad/sandwich prep tables come with 6" casters, plastic coated wire shelving and a 3/4" thick polyethylene cutting board. The front LED readout makes it easy to see the interior temperature. These models are ETL Listed and ETL Sanitation. They are backed with a 1 year warranty on parts and labor and a 5 year warranty on the compressor.

Mega Top Salad/Sandwich Prep Tables

- 430 series stainless steel exterior
- 304 series stainless steel interior
- Precise digital temperature controller with LED display
- Foamed-in-place polyurethane high density cell insulation throughout the entire cabinet
- Oversized hinged insulated lid
- Automatic defrosting
- Removable door gasket
- Recessed door handles
- 3/4" thick removable polyethylene cutting board
- Clear plastic food pans included
- (4) 6" casters (2 locking and 2 non-locking)
- 1 year warranty on parts and labor
- 5 year warranty on the compressor



USSLM-1D



USSLM-2D



USSLM-3D



Specifications

Model	Doors	Shelves	Net Volume (Cubic Ft)	Overall Dimensions WxDxH (inches)			HP	Voltage	Amps	Gross Weight
USSLM-1D	1	1	6	27.5"	34"	46"	1/4	115V	5.3	213 lbs
USSLM-2D	2	2	9.5	47"	34"	46"	1/3	115V	7.8	280 lbs
USSLM-2D/60	2	2	15	60"	34"	46"	1/3	115V	7.8	346 lbs
USSLM-3D	3	3	15.5	66"	34"	46"	1/2	115V	8.8	379 lbs

Plan Views

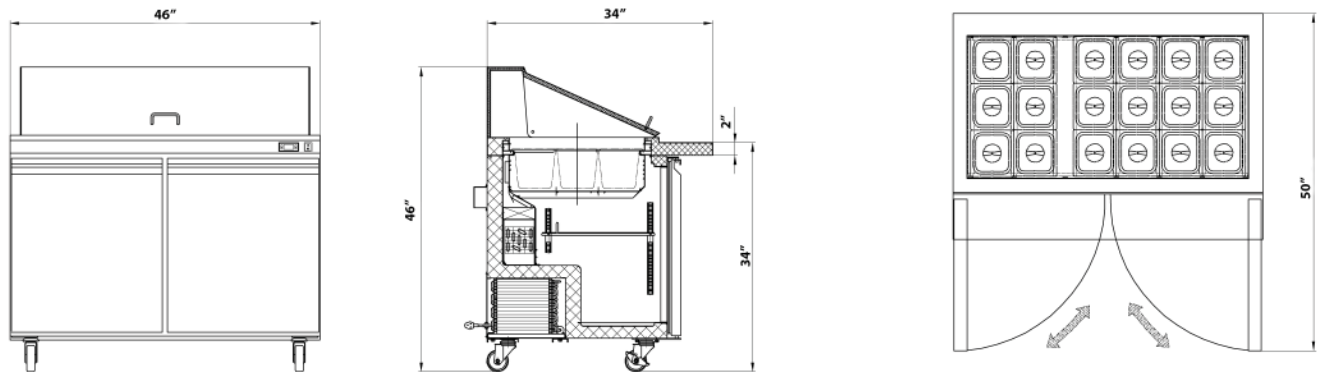

USSLM-2D

Features

Refrigeration System

- Refrigeration units use environmentally friendly R134A refrigerant
- Maintain a temperature range of 32°-41°F
- Rugged built axial evaporator fans run efficiently with low velocity and high volume air flow

Electrical Control

- Electric LED temperature controller provides a digital display of cabinet temperatures and allows for easy temperature adjustments when necessary
- Front LED temperature display lets you know the internal temperature without having to check inside
- Temperature controller initiates automatic defrost schedule for worry free use
- 7 foot power cord with NEMA 5-15 plug



Cabinet Construction

- Exterior is constructed of 430 stainless steel including the doors
- Interior is constructed of 304 stainless steel
- The cabinet is insulated throughout with a foamed-in-place high density cell polyurethane insulation

Door(s)

- Stainless steel exterior with matching aluminum liner on the inside
- Positive self-closing doors with microswitch that shuts the evaporator fans off when the door is open
- Recessed handles are built into the door for easy opening and closing
- Removable door gasket for easy cleaning

Shelving

- Adjustable plastic coated steel shelves that have a load capacity of up to 90 lbs per shelf
- Specially designed stainless steel racking system allows for easy shelf height adjustment and gives the user the ability to slide out the shelf to better reach the food inside

Model Features

- Oversized insulated hinged lid to keep food cold while not in use
- 6" casters come standard on all stainless steel models 2 locking and 2 non-locking.
- 3/4" thick poly cutting board
- Clear plastic food pans included