

Project: _____
 Location: _____
 Item #: _____ Quantity: _____
 Model #: _____

MODEL: IRT-UC60P

**REACH-IN:
 Slimline Reach-in Refrigerators (Glass Door)**



General Strengths

- ✓ **Sanitation.** The inside of the table is constructed with rounded corners (large radius for easy cleaning). Possibility to quickly remove shelves and runners for interior cleaning. Each table has a drain at the bottom of the unit. When cleaning the unit, make sure the drain hose is directed to a floor drain.
- ✓ **Doors.** Self-closing door system with permanent pressure. Stay open feature included when door remains open after 95 degrees. All doors include triple chamber door gaskets, easy to remove and snap in. Doors are field reversible.
- ✓ **Control systems.** Higher precision in managing temperature settings. Greater ability for the adjustment of temperatures ranges as per the end user's requirement.
- ✓ **100% Tested.** All condenser units are tested 100%, in helium chambers to refrigerant leak detections.
- ✓ **Certified.** Audited and Certified by **INTERTEK** for compliance with UL 471 and NSF 7. EQA audited and certified by internationally recognized firm. ISO 9001:2015 (Quality); ISO 14001:2015 (Environmental); ISO 45001:2018 (Prevention and Worker Safety)

Revision:01 Date: 12/05/2022 IRT-UC60P

MODELS	Dimensions (inches) (mm)			Doors	Shelves	Ref.	Ref. Weig ht (Lbs.) (gr.)	Temperature Range (°F) (°C)	Cond. Unit (H.P)	Capacity (Cu.Ft.) (L)	Case Amps 115V	Net weight (Lbs.) (Kg.)
	W	D	H									
IRT-UC60P	60-1/2 (1536)	30-1/8 (765)	46-1/4 (1175)	2/16	4/4	R290	0,24 (110)	35 °F/41 °F (+2°C/+5°C)	1/4	17 (481)	4,1	430 (195)

ETL LISTED TO UL471 STANDARD AND SANITATION CLASSIFIED TO NSF7 – WE RESERVE THE RIGHT TO CHANGE SPECIFICATIONS WITHOUT PRIOR NOTICE



INFRICO-North America Corporate División
 1409NW 84th Avenue, Doral FL 33126
 (305) 777 9599 ext.700 / f (305) 777 9598
 Toll Free 855-340-4637

www.infrico.us
sales@infrico.com
service@infrico.com

MODEL: IRT-UC60P

REACH-IN:
Slimline Reach-in Refrigerators (Glass Door)

STANDARD FEATURES

➤ **Exterior**

- AISI 304 Stainless Steel,
- AISI 304 Stainless Top.

➤ **Interior**

- AISI 304 Stainless Steel,

➤ **Doors**

- Polyurethane insulated door,
- Self – closing door with stay open feature,
- Stainless Steel heavy-duty hinges,
- Triple chamber snap in door gaskets for easy removal and cleaning,
- Field reversible door,
- Full-height door opening: 25-5/8" x 21-7/8" (650x555 mm)

OPTIONAL FEATURES

- ✓ Electrical connection is: 220 – 230 V / 1 ph / 50 Hz (plug type varies).
- ✓ Flat lid,
- ✓ Single Overshelf,
- ✓ Double Overshelf,
- ✓ Set of 2" diameter casters, with lock provided on front set,
- ✓ Drawer kit: 23-1/2" x 12 -5/8" (596x509x320 mm).

✓ **Insulation**

- CF3-Free polyurethane insulation, entire cabinet structure is foamed-in place using a high density polyurethane insulation,
- Low GWP & Zero ODP effect.

✓ **Salad Top**

- Stainless Steel insulated lid,
- Top includes 1/6 size polycarbonate food pans, (16 pans),
- Pan divider bars included for varying size pan configurations,
- Removable sanitary polyethylene cutting board included.

➤ **Shelving**

- (2) Two plastic coated wire shelves,
- Set of Stainless Steel shelf brackets,
- Easy remove for cleaning,
- Dimensions WxD: 27-1/4"x 17" (692x432 mm).

➤ **Casters**

- 4" diameter casters,
- Locks provided on front set.

➤ **Refrigeration**

- Temperature regulated by thermostatic control,
- Evaporative pan,
- Evaporator coil coated with anti-corrosion material 100% polyester,
- Forced air refrigeration system,
- Refrigeration capacity: 1348 Btu/h (14°F) / 395 W (-10°C).

➤ **Electrical**

- Cord and NEMA 5-15P plug,
- Electrical connection is 115 V / 1ph / 60 Hz.



➤ **ETL Listed to UL471 Standard and Sanitation classified to NSF7.**

ETL LISTED TO UL471 STANDARD AND SANITATION CLASSIFIED TO NSF7 – WE RESERVE THE RIGHT TO CHANGE SPECIFICATIONS WITHOUT PRIOR NOTICE



Project: _____
 Location: _____
 Item #: _____ Quantity: _____
 Model #: _____

MODEL: IRT-UC60P **REACH-IN:**
Slimline Reach-in Refrigerators (Glass Door)

ELEVATION **RIGHT VIEW** **PLAN VIEW**

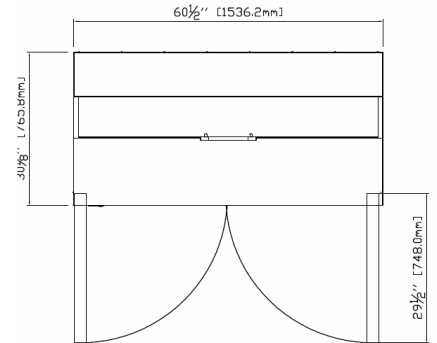
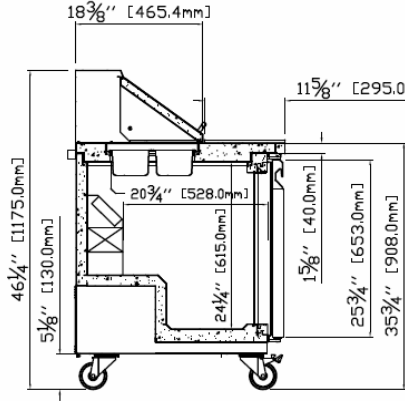
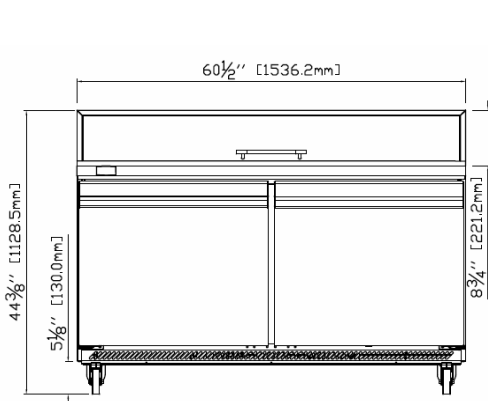

ETL LISTED TO UL471 STANDARD AND SANITATION CLASSIFIED TO NSF7 - WE RESERVE THE RIGHT TO CHANGE SPECIFICATIONS WITHOUT PRIOR NOTICE

Revision: 01 Date: 12/05/2022 IRT-UC48P



INFRICO-North America Corporate División
 1409NW 84th Avenue, Doral FL 33126
 (305) 777 9599 ext.700 / f (305) 777 9598
 Toll Free 855-340-4637

www.infrico.us
sales@infrico.com
service@infrico.com