



Features

Eco-Friendly Refrigerant

R290 refrigerant with a global warming potential (GWP) of 3

High-Strength Door

Heavy-duty, stainless steel door assembled using high-load brackets for long lasting durability

Long-Lasting, Removable Gaskets

Santoprene™ gaskets last four times longer than standard gaskets

Easy to Clean

Aluminum interior, coved corners, finished edges, and removable shelves

Heavy-Duty Soft Casters

Secured to a 12 gauge steel base to ensure years of worry-free operations

High-Efficiency Refrigeration System

Forced air circulation provides uniform temperature throughout the cabinet

Cabinet Capacity

Internal area of 11.56ft³ with four (4) heavy-gauge wire shelves — adjustable in 1/2" increments using stainless steel pilasters

Stainless Steel Exterior

Galvanized back and bottom to reduce the risk of corrosion

High-Density Insulation

Foamed-in-place, CFC-free polyurethane insulation for maximum strength, rigidity, and insulation

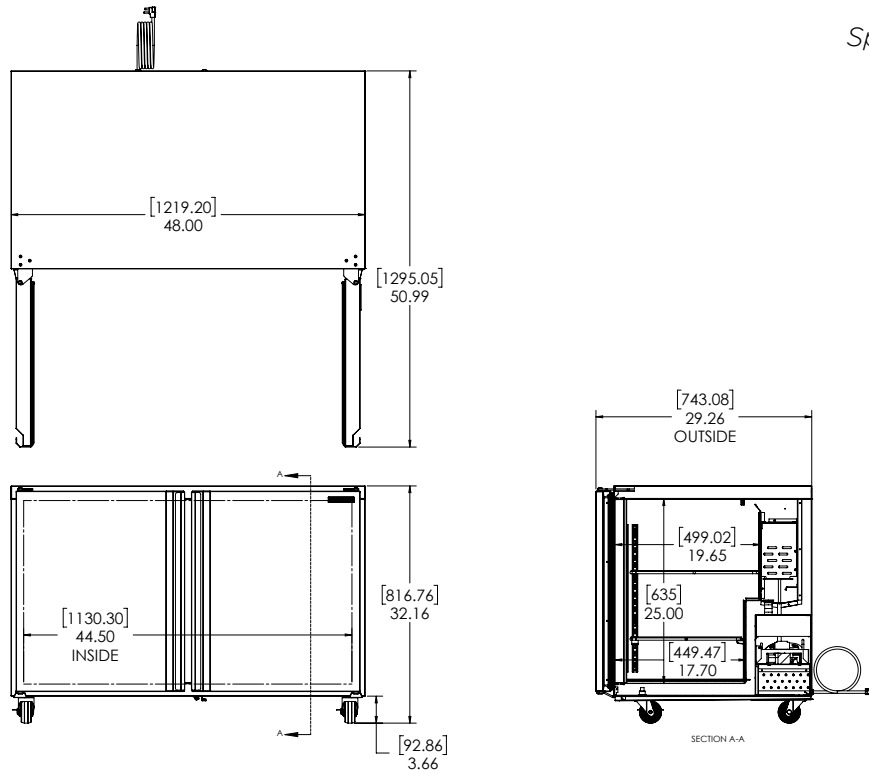

Technical Specifications

Electrical Requirements	115v/60hz/1ph/3.7A/NEMA 5-15P Plug
Product Dimensions	48"W x 32.16"H x 30.18"D (121.92cm x 81.69cm x 76.66cm)
Product Weight	250lbs (113.40kg)
Shipping Dimensions	53"W x 42"H x 35"D (134.62cm x 106.68cm x 88.90cm)
Shipping Weight	265lbs (120.20kg)
Shipping Cubic Dimensions	45.09ft ³ (1.28m ³)
Temperature Range	36 to 38 (2.22 to 3.33°C)
Refrigerant	R290

Insulation	Foamed-in-place, CFC-free polyurethane
Exterior Construction	Stainless steel exterior with galvanized back and bottom
Interior Construction	Aluminum interior with coved corners and finished edges
Doors	Two doors, one (1) left-hand and one (1) right-hand swing
Shelves	Four (4) heavy-gauge wire shelves
Interior Capacity	11.56ft ³
Door Gasket	Santoprene™ gasket
Casters	Four (4) 3" heavy-duty casters (two locking)
Certifications	ETL Safety, ETL Sanitation
Warranty	1-year parts and labor, 5-year compressor (part only)

Model Number	Description
SKR48A-EGUS1	Undercounter Refrigerator 48", 115v/60hz/1ph, dual swing doors, 3" heavy-duty soft casters (two locking), NEMA 5-15P

To learn more about **Silver King Undercounter Refrigerator**, visit silverking.com