



AMERICAN EAGLE[®]
FOOD MACHINERY, INC.

AE-DDE30R / 36R
Elite Series
Dough Divider Rounder

773.376.0800 (P) • 773.376.2010 (F) • 3131 S. Canal St. Chicago, IL 60616

**American Eagle[®] Elite Series Dough Divider Rounders
 Feature a Unique Dual Cam Design For Added Stability
 And Precision Finishing Capabilities!**

Quality Design

- Powerful 2 HP Motor
- Secondary Rear Cam For Extra Rounding Stability
- Heavy Duty, Rigid Cast Iron Construction
- Self Lubricating, Enclosed Motor And Transmission For Food Safety And Low Maintenance
- Stainless Steel Cutting Knives
- Machine Head Tilts For Easier Cleaning
- Dual Stage, Semi-Automatic Operation, Divide Then Round
- Heat Treated Enamel White Finish Resists Rust, Scratches, And Dents
- ETL And CE Certified



AE-DDE36R Shown



Secondary Cam

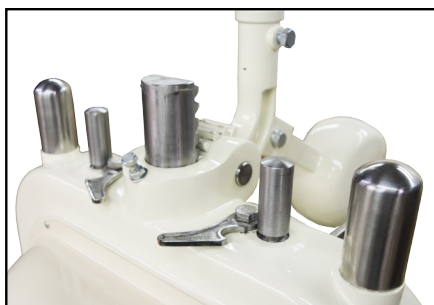

**Extra Large Ram And Spindle Rods
 With Built-In Safety Locking Tabs**

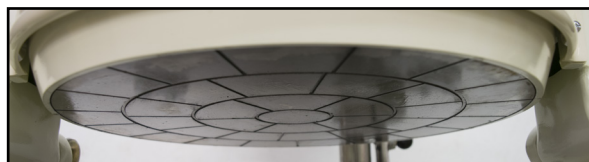

**Precision Dividing Head
 And Stainless Steel Knives**

Standard Features

- Horizontally Mounted Variable Speed Lever For Extra Precise Rounding Control
- Adjustable Leveling Feet Provide Extra Stability
- Independent On/Off Switch And Circuit Breaker
- Heavy Duty, 6 Foot Hard Wired Power Cable
- Warranty: 1 Year Parts And Labor*

Standard Accessories

- Three Divider-Rounder Plates
- Heavy Duty Removable Push Rod

Proud Member of:

 North American Association of
 Food Equipment Manufacturers

Quality • Value • Reliability



AMERICAN EAGLE[®]
FOOD MACHINERY, INC.

AE-DDE30R / 36R
Elite Series
Dough Divider Rounder

sales@ameagle.biz • www.americaneaglemachine.com

American Eagle® Elite Series Dough Divider Rounder Machines Are Perfect For Supermarket Bakeries And Retail Bake Shops. They Are Easy To Operate And Handle A Variety Of Dough And Weights. Enjoy The Best Performance With Our Premium Design!

Specifications

Model	Motor	Voltage V/HZ/PH	Pieces Per Cut	Piece Weight Range	Batch Dough Weight	Productivity Pieces/Hour
AE-DDE30R	2 HP	220/60/1	30 Pieces	1.375 - 3.875 oz (40 - 110 g)	2.5 - 7.25 lbs (1200 - 3300 g)	6000-7000
AE-DDE36R	2 HP	220/60/1	36 Pieces	1.125 - 2.5 oz (32 - 70 g)	2.5 - 5.5 lbs (1150 - 2520 g)	6000-7000

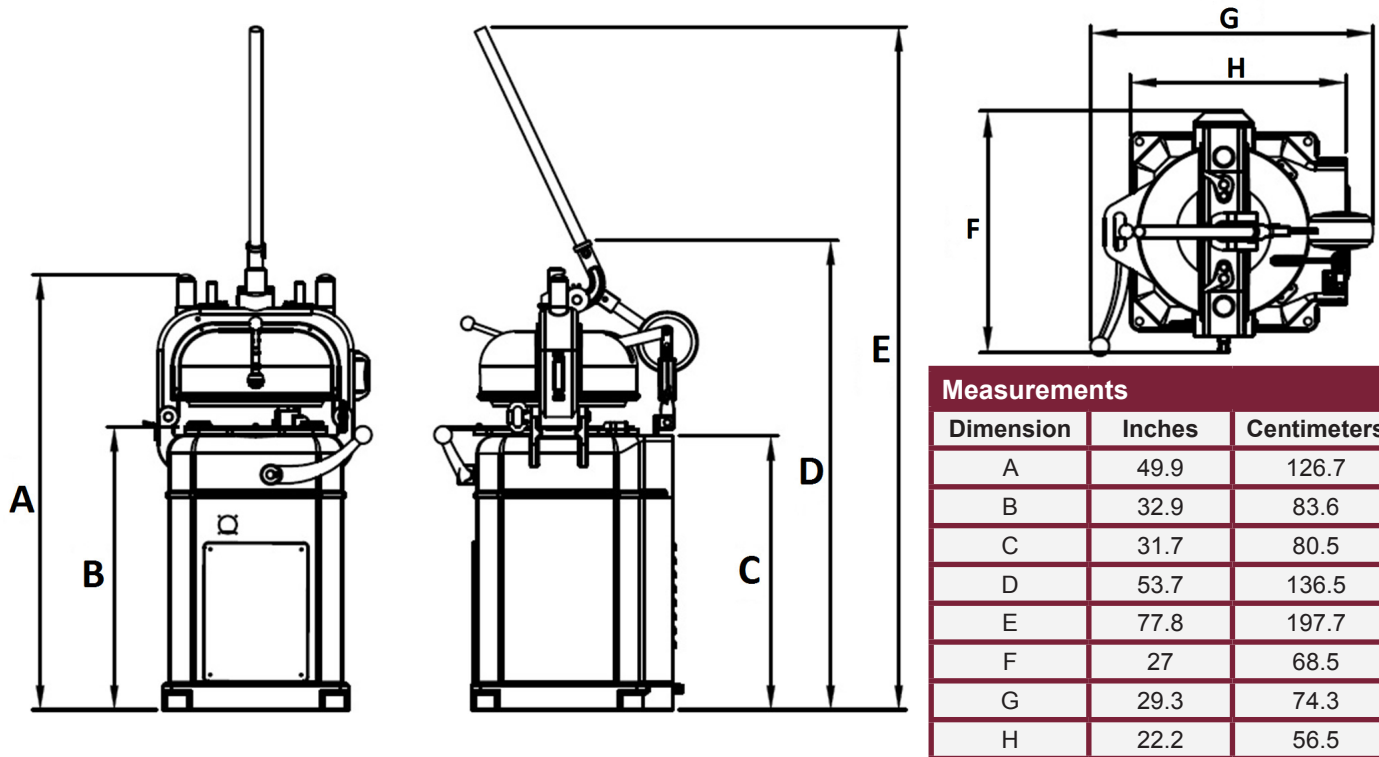

Dimensions and Shipping Information

Model	Overall Dimensions (w/Lever)	Foot Print	Net Weight	Shipping Dimensions**	Ship Weight	Freight Class
AE-DDE30R	27"W x 29.3"L x 53.7" (77.8"H)	23"W x 23"D	796 lbs (361 kg)	33"W x 37"L x 69"H	885 lbs (402 kg)	85
AE-DDE36R	27"W x 29.3"L x 53.7" (77.8"H)	23"W x 23"D	796 lbs (361 kg)	33"W x 37"L x 69"H	885 lbs (402 kg)	85

*Warranty must be registered. Damage due to improper installation voids warranty, machine must be bolted and secured to ground during installation

**Crates are affixed to a skid (pallet). The weight and dimensions of this skid are included above and may vary from shipment to shipment.



Quality • Value • Reliability