



# CHEF BASE

MODEL DCB52-60



## PRODUCT FEATURES

- Digital temperature control features a digital display to make monitoring interior temperatures a breeze. This unit also comes with an auto-defrost function.
- Foamed-in-place insulation keeps the interior cold and adds structural strength.
- Stainless steel Interior with rounded corner for easy cleaning. Meet and exceed sanitation standards.
- Durable and high weight bearing rails for drawers.
- Heavy-duty 4" casters with brakes are included providing the unit with convenient mobility, making cleaning and servicing a breeze! Just roll the unit away from the wall.
- Ergonomic and modern recess door handles.
- Removable Drawer Gaskets, each drawer gasket is removable for easy cleaning and maintenance.



## TECHNICAL SPECIFICATIONS

Voltage/Frequency 115V/60HZ  
 Refrigerant R290/2.29oz  
 Type of Defrost Automatic  
 Interior Material 304/201 Stainless Steel  
 Exterior Material 304/201 Stainless Steel  
 Total Current 2.088A  
 Climatic Category 4-5  
 Nema Config. NEMA5-15P

TEMPERATURE RANGE (F°)	EXTERNAL DIMENSION WxDxH (INCHES)	PACKAGING DIMENSION WxDxH (INCHES)	PRODUCT NET WEIGHT	DRAWERS	40 HQ CONTAINER CERTIFICATION
33~38°F	60x32 1/4"x26 5/8"	54 1/8"x34 1/4"x29 1/8"	246 lbs	2	45

\* All measures are presented in inches and pounds



## HIGH QUALITY STAINLESS STEEL & ROBUST DESIGN



Los Angeles | San Francisco | Dallas  
 Houston | Florida | Chicago | New Jersey

1-800-931-8628

@ info@dukersusa.com

www.DukersUSA.com

# DETAILS & SPECIFICATIONS

## CHEF BASE

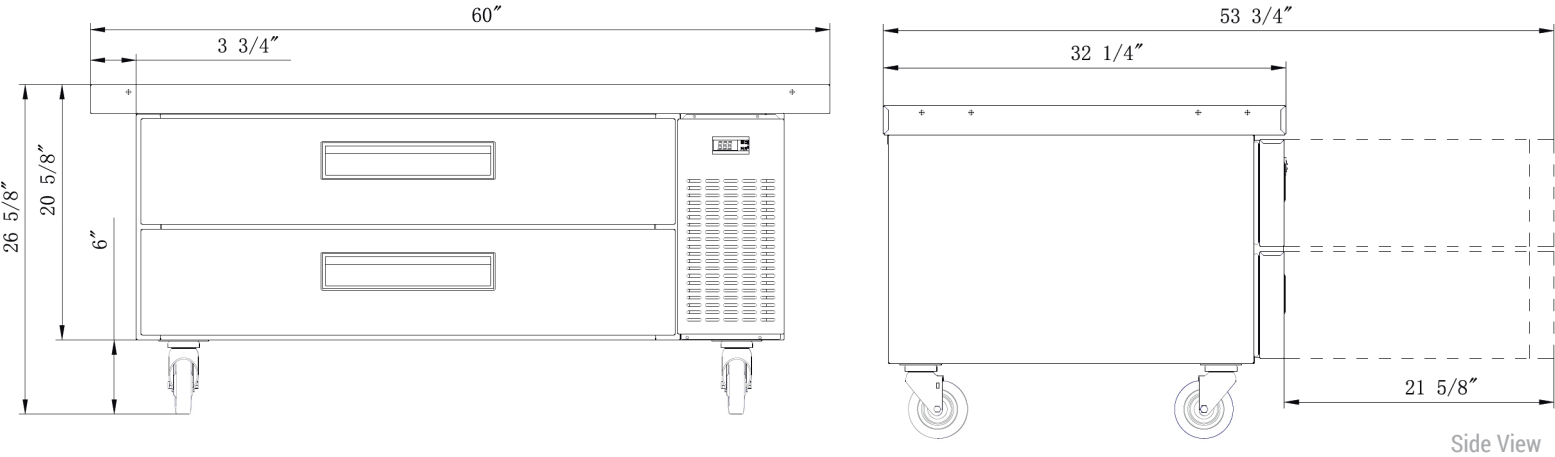

Side View

### MODEL DCB52-60

Rated Voltage	115V
Rated Frequency	60Hz
Total Input Power	200W
Total Current	2.088A
Climatic Category	4-5
Protection Type	I
Design Pressure High Side	300 PIG
Design Pressure Low Side	150 PIG
Insulation Blowing Gas	C-Pentane
Net Weight	246 lbs
Nema Config.	NEMA5-15P
Temperature Range	33~38°F
Heating Power	236.9W
40 HQ Container Certification	45
Refrigerant	R290/2.29oz
1/6 Pan Count	18

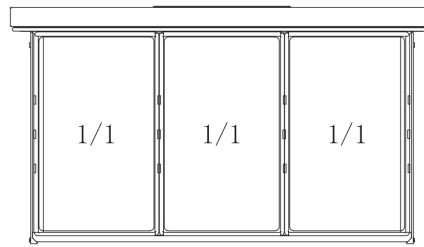

FULL PANS

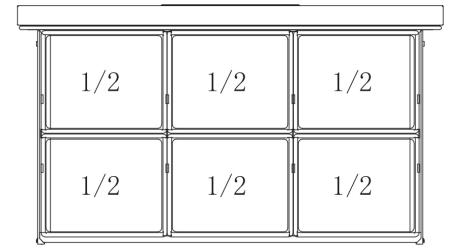

HALF PANS

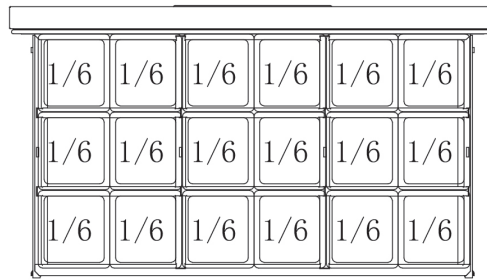

SIXTH PANS

Pan Layout



Los Angeles | San Francisco | Dallas  
Houston | Florida | Chicago | New Jersey

1-800-931-8628

@ info@dukersusa.com

www.DukersUSA.com