



Commercial Gas Ranges HKN-XRFG6006G24A

6 burner with oven and griddle

Item #: HKN-XRFG6006G24A /US Project: _____

Qty: _____ Date: _____ Approval: _____



Features

- 1 Sabaf oven valve
- 2 Robertshaw thermocouple
- 3 Maxitrol gas regulator
- 4 250F - 450F
- 5 5, 6" Adjustable stainless steel legs
- 6 Gas conversion kit
- 7 Heavy -duty cast Iron lift-off grates
- 8 2" front ledge workspace
- 9 9 3/4" deep shelf on the back-riser

Technical Data

Width	60 Inches
Depth	32 5/8 Inches
Height	60 2/8 Inches
Oven Interior Width	26 4/8 Inches
Rack Width	25 3/8 Inches
Oven Interior Depth	25 6/8 Inches
Rack Depth	23 4/8 Inches
Oven Interior Height	13 7/8 Inches
Burner BTU	30000 BTU
Burner Style	Grates



Technical Data

Control Type	Manual
Gas Inlet Size	3/4 Inches
Installation Type	Freestanding
Maximum Temperature	550 Degrees F
Number of Burners	6 Burners
Number of Ovens	2
Number of Racks	2 racks/oven
Oven BTU	31000
Power Type Natural	Natural Gas
Range Base Style	Space Saver Oven
Total BTU	282000 BTU

Certifications



ETL, US



ETL Sanitation



3/4" Gas Connection



Field Convertible (Gas)



HURAKAN RANGE

Plan View

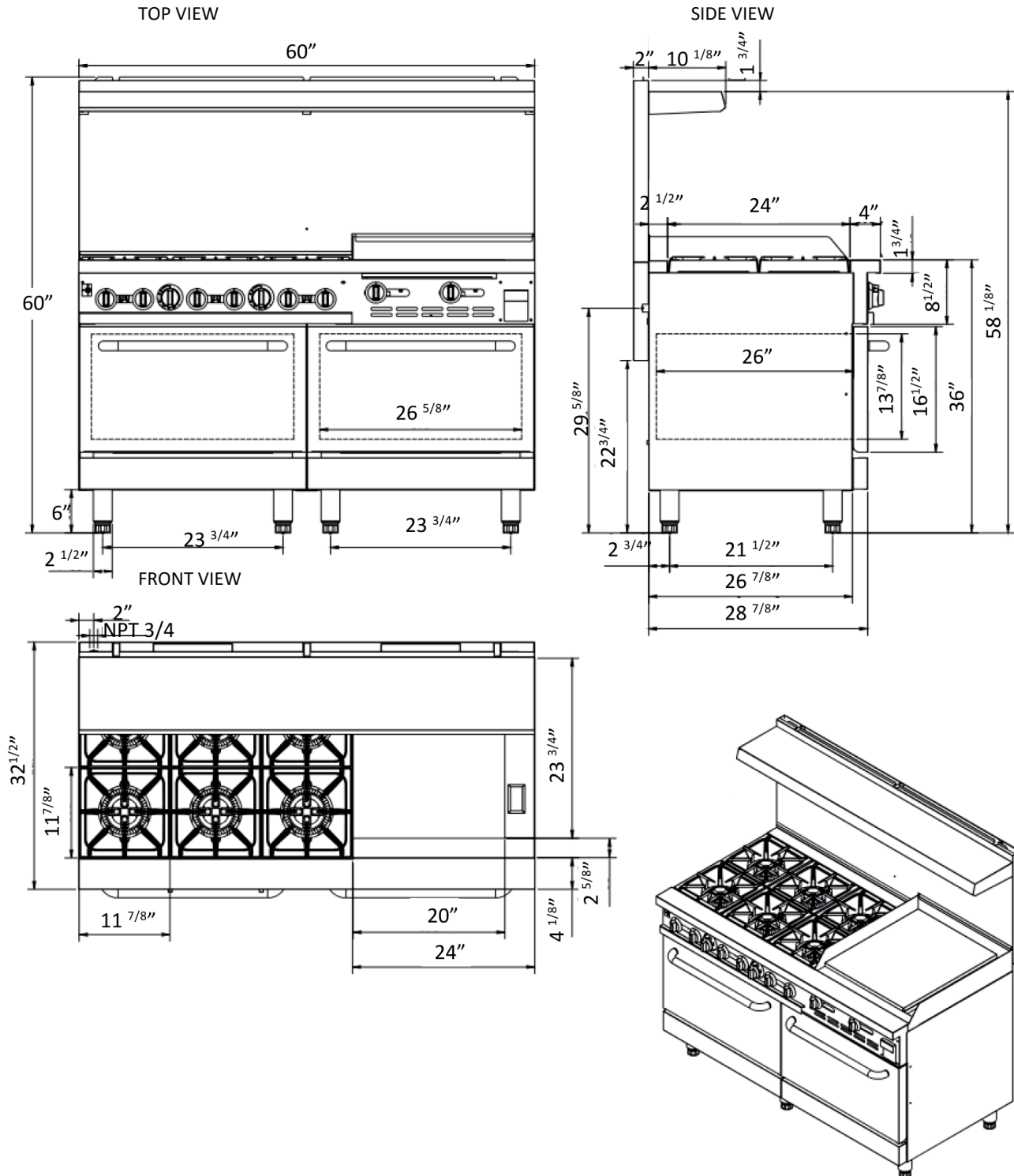



Notes & Details

6 Burner Range with 2 Ovens and Griddle.

Introducing our premium commercial gas range, meticulously engineered for unparalleled performance and durability. Crafted with a fully MIG welded frame, this range ensures exceptional stability even in the busiest kitchen environments. The stainless steel front and back-riser guarantee longevity and easy maintenance, while the 6" adjustable heavy-duty legs provide stability on any surface.

Equipped with six open top burners, each boasting an impressive 30,000 BTU/hr output, this range delivers precise cooking control for a variety of culinary tasks. To ensure uninterrupted operation, the coved pilot burner cover prevents clogging from spillage, while the stainless steel pilot ensures long-lasting reliability.

Designed for efficiency and ease of use, the heavy-duty cast grates and pull-out crumb tray simplify cleaning, while the rounded edges of the crumb tray prevent heat transfer. The bottom oven features a powerful 31,000 BTU/hr U-shape burner, complemented by two 20,000 BTU/hr burners for the griddle, offering versatile cooking options to suit diverse menu items.

With the capability to accommodate full-size sheet pans in multiple configurations, including side-to-side or front-to-back, this range maximizes cooking space and flexibility. The oven thermostat, adjustable from 250 to 550 degrees Fahrenheit, ensures precise temperature control for consistent results. Additionally, two oven racks with four rack positions cater to various baking needs.

For added convenience, the range features a 24" griddle plate with 3/4" thickness, ideal for preparing breakfast items, sandwiches, and more. Optional castors provide mobility for effortless repositioning within the kitchen space. Experience unmatched performance and reliability with our commercial gas range, designed to elevate your culinary endeavors to new heights.

Instructions and images in this manual are only for reference and may differ from the actual product. Launch the E-Manual.