







BLUELAMA



HOT PLATE BLHP12 TWO BURNER

PRODUCT DESCRIPTION

-  28,000 BTU Per Burner. Stainless Steel construction with Ever-Ready Standby pilots.
-  Lift Off 12" x 12" Cast Iron Burner Grates.
-  Independent Manual controls every 12"
-  Cool Touch Stainless Steel Landing ledge.
-  Hot Plates are all Natural Gas (NG) Standard. LP conversion kit is included.
-  Heavy Duty Stainless Steel construction.
-  Full length seamless drip pan, easy to remove and clean.

MODEL#	DIMENSIONS		
	Width	Depth	Height
BLHP12	12 in	28 3/4 in	12 7/8

* All measurements are presented in Inches



DETAILS & SPECIFICATIONS

HOT PLATE BLHP12 TWO BURNER

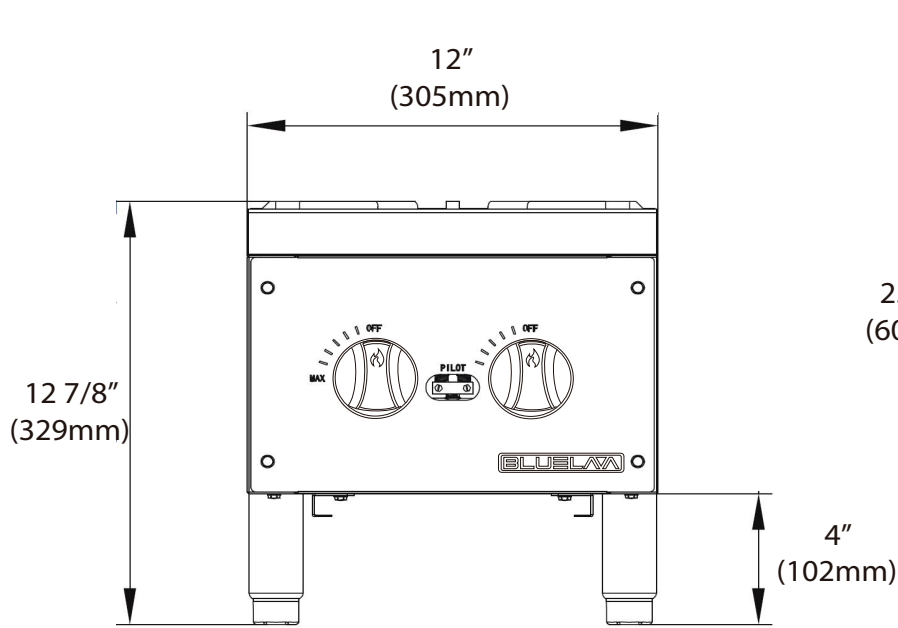

Front View

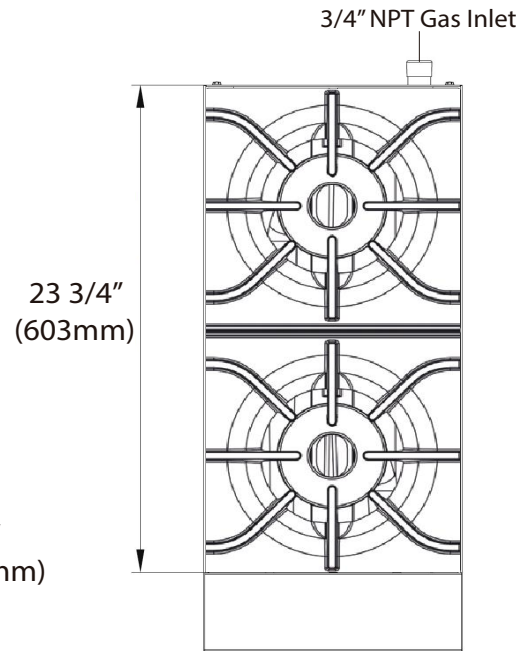

Top View

BLHP12	
GAS	NG/Propane
WORK AREA	11.81"x23.62"
BURNERS	2
BTU/H PER BURNER	28,000
TOTAL BTU/H	56,000
GAS PRESSURE	NG: 4" WC Propane: 10" WC
NOZZLE	NG: 40# Propane: 52#
CONTAINER FITMENT	480

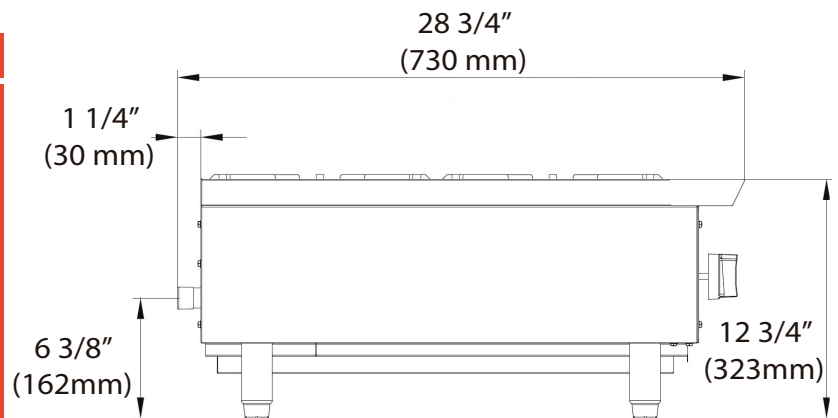

Side View

Model	Packaging Dimensions (inches)			Net Weight (lbs)	Ship Weight (lbs)
	W	D	H		
BLHP12	14 1/8"	32 5/8"	17 3/4"	66	88

BLUELAA

orders@blueairfse.com



223 W. Rosecrans Ave., CA 90248
9 W. Shelton Terrace #A, Hillside, NJ 07205
7025 Amwiler industrial Drive, Suite A, Atlanta GA



T: 310-808-0102
T: 908-688-0970
T: 470-625-0182