



AMERICAN EAGLE[®]
FOOD MACHINERY, INC.

AE-DSE45B / 52B
Elite Series Countertop
Dough Sheeters

773.376.0800 (P) • 773.376.2010 (F) • 3131 S. Canal St. Chicago, IL 60616

AE-DSE52B SHOWN



Fold Up Working Surface
Saves Counter Space!



Quality Design

- Powerful 1/2 HP Motor
- Reversible Sheet With Sync Drive (Output Conveyor Is Faster Than Input)
- 100% Gear And Chain Driven Transmission
- Heavy Duty Canvas Belts Mounted On Integrated Roller Guides Minimize Conveyor Adjustments
- Enamel Clear Layer Finish Heat Treated On White Body Panels Resist Rust, Scratches And Dents
- Thermal Overload Protection With Reset Button Protects Motor
- ETL And CE Certified

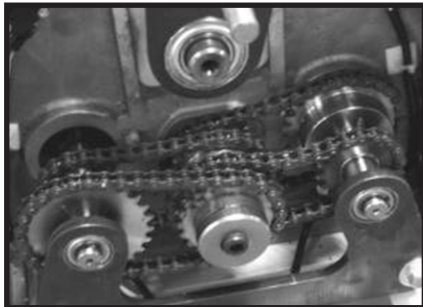

Heavy Duty Steel Gears
Mounted On Ball Bearings
Drive A Permanently Lubricated
Chain For Minimal Maintenance!

Standard Features

- Independent On/Off Switch And Emergency Stop
- Dual Catch Pans, One On Each End
- Main Roller Adjustment Lever With Integrated Lock
- Convenient Front Mounted Motor Control Lever
- OSHA Compliant Safety Guard With Auto-Shutoff
- Warranty: 1 Year Parts / 1 Year Labor*



Extra Large Front Mounted Controls

Integrated Lock



Proud Member of:
NAFEM
 North American Association of
 Food Equipment Manufacturers

Quality • Value • Reliability



AMERICAN EAGLE[®]
FOOD MACHINERY, INC.

AE-DSE45B / 52B
Elite Series Countertop
Dough Sheeters

sales@ameagle.biz • www.americaneaglemachine.com

Our Elite Series Machines Feature Premium Design, Safety Features, And Reliability. Lower Your Total Cost Of Ownership And Enjoy Peace Of Mind With A Longer Labor Warranty!

Specifications

Model	Motor	Voltage V/Hz/PH	Amps	Main Roller Size	Adjustable Thickness	Max Dough Batch**	Working Surface	Safety Guard	Foot Pedals
AE-DSE45B	1/2 HP	220/60/1	5	3.5" Dia x 18.5" L (9cm x 47cm)	.004" to 1.18" (0.1 to 30mm)	8.82 lbs 4 kg	17.7" x 67" 45cm x 170cm	Yes	No
AE-DSE52B	1/2 HP	220/60/1	5	3.5" Dia x 21.5" L (9cm x 55cm)	.004" to 1.18" (0.1 to 30mm)	12.13 lbs 5.5 kg	20.5" x 67" 52cm x 170cm	Yes	No

Measurements

Dimension	AE-DSE45B		AE-DSE52B	
L	70.9 in	180 cm	70.9 in	180 cm
W	31.9 in	81 cm	35.8 in	91 cm
H	23.6 in	60 cm	23.6 in	60 cm
Z	27.6 in	70 cm	27.6 in	70 cm
Y	32 in	80 cm	31.5 in	80 cm

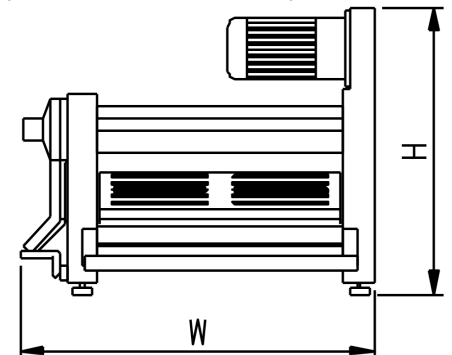
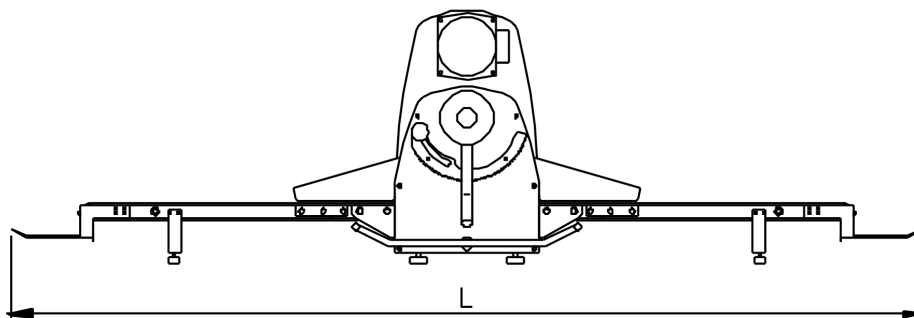
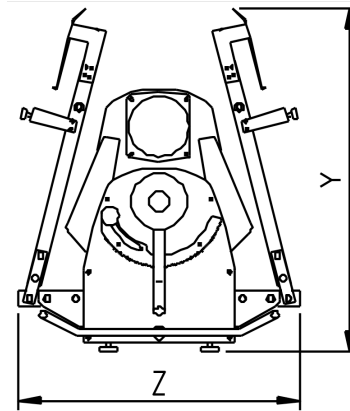

Dimensions and Shipping Information

Model	Overall Dimensions	Shipping Dimensions***	Net Weight	Ship Weight	Freight Class
AE-DSE45B	70.9" L x 31.9" W x 23.6" H (180cm x 81cm x 60cm)	48" L x 40" W x 45" H (122cm x 102cm x 114cm)	261 lbs (118 kg)	364 lbs (165 kg)	85
AE-DSE52B	70.9" L x 35.8" W x 23.6" H (180cm x 90cm x 62cm)	48" L x 40" W x 45" H (122cm x 102cm x 114cm)	274 lbs (124 kg)	377 lbs (171 kg)	85

*Warranty must be registered. Improper electrical connection voids warranty. Ensure supplied power matches specification on nameplate

**Weights are approximate and assume 60% AR ratio for typical bread dough, adjust load accordingly, overloading voids warranty

***Crates are affixed to a skid (pallet). The weight and dimensions of this skid are included above and may vary from shipment to shipment.



Quality • Value • Reliability