

# RAFFAELLO 350 EVO TOP - 14"

*Heavy-duty Deli / Supermarket slicer*

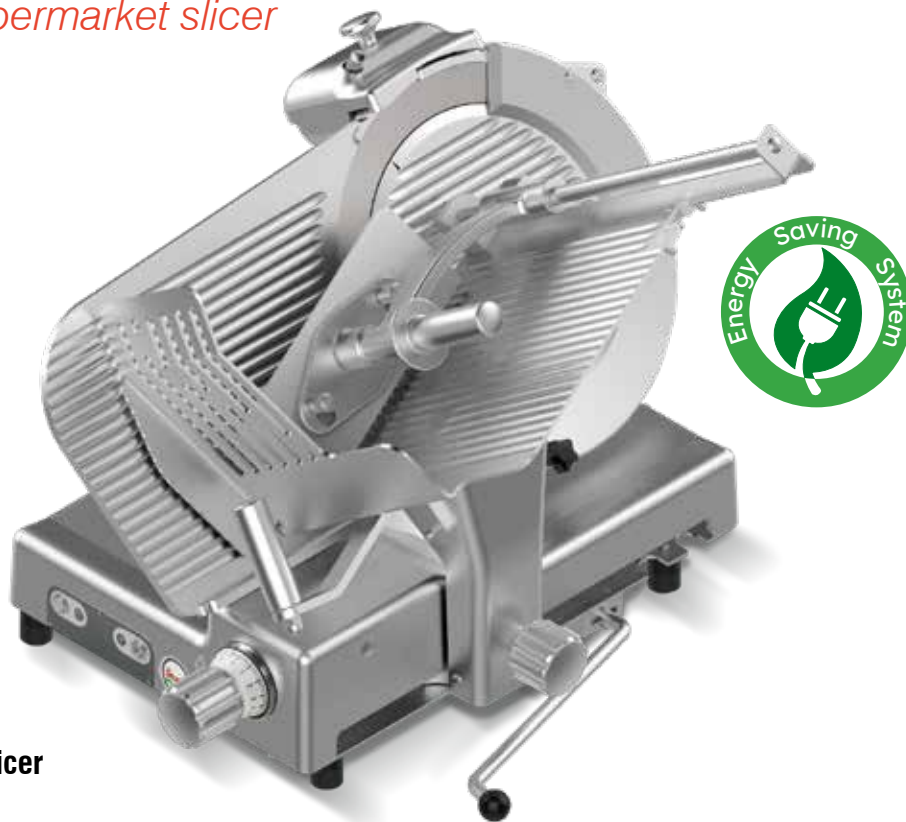

**The EVolution continues with Raffaello 350 EVO TOP**  
**14" full-size capacity, heavy duty slicer designed for high-volume retail applications, setting the highest standards in the industry for:**

## Dependability, Yield and Profitability

- One-piece sanitary polished and anodized aluminum construction
- Longest carriage travel for the widest cut capacity
- Low-profile, ergonomic design with an extremely smooth carriage motion
- ½ Hp heavy-duty motor for continuous service and higher torque for cheese slicing
- Stainless steel controls, IP67 dustproof and waterproof rating
- Dual stage cam system allows precise, thin and thick slicing
- Complete stainless steel drive shaft assembly
- Built-in sharpener for perfect results and safety - unlike remote devices
- Waterproof from above

<b>Operation:</b>	Gravity feed.
<b>Construction:</b>	Polished, anodized aluminum alloy.
<b>Knife:</b>	One piece, chromium plated 100Cr6 forged carbon steel blade.
<b>Sharpener:</b>	Built-in, removable, two stone dual action.

## Optional

- 19705020 Vegetable Chute
- 19510453R Fence, rectangular/round products

## Hygiene and Safety

- All metal knobs, handles and dials, minimized use of plastic
- Rounded, edgeless design
- Increased gap between blade and machine body
- One-piece carriage with seamless, see-through hand guard
- Improved blade guard removal system
- Zero blade exposure to prevent injuries when cleaning
- Tilt-carriage with zero blade exposure
- Permanent blade rim guard covering the non-slicing portion of the blade edge
- Lift lever to easily and safely clean under the slicer (factory installed option)
- Overload protection
- No volt release
- Certified to and exceeding the NSF ANSI 8 2010 standard
- SM Package: Automatic turn-off + Thickness dial at zero turn-off + Start at zero

<b>Slice thickness:</b>	0-1" (0-24 mm), infinitely variable
<b>Motor:</b>	0.55 Hp (410 W), fan cooled.
<b>Electrical:</b>	120V AC, 60Hz, 2.6A.
<b>Plug &amp; Cord:</b>	Attached, flexible, 3 wire SJTO AWG 18, 6'4" long. NEMA 5-15 P
<b>Controls:</b>	ON/OFF stainless steel keypad, IP 67 waterproof protection. No voltage release.

**UL US LISTED**  
 Certified to UL Standard 763  
 and NSF Standard 08  
 Certified to CSA Standard C22.2

**ETL SANITATION LISTED**



Improved blade guard removal system



Completely sealed stainless steel shaft



NSF ANSI 8 design



One-piece carriage with seamless, see-through hand guard



Increased gap between blade and machine body



Dual stage cam system allows precise, thin and thick slicing



Tilt-carriage with zero blade exposure



Lift lever



Vegetable Chute option

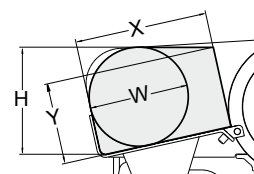
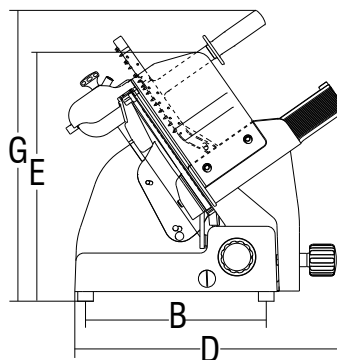
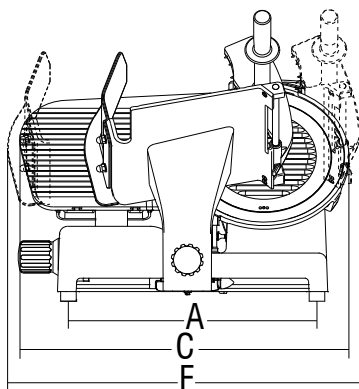

	Ø Blade	Motor	Cut thickness	Blade rpm	Carriage stroke	Hopper	A	B	C	D	E	F	G	X	Y	H	W	Net weight	Shipping	Gross weight
	mm/inch	watt/Hp	inch.	rpm	inch.	inch.	inch.	inch.	inch.	inch.	inch.	inch.	inch.	inch.	inch.	inch.	inch.	lbs.	inch.	lbs.
<b>Raffaello 350 EVO TOP</b>	350/14"	410-0.55	1"	319	14"	13 <sup>3/4</sup> " x 11 <sup>1/4</sup> "	20 <sup>5/16</sup> "	13 <sup>3/8</sup> "	28 <sup>1/8</sup> "	25 <sup>3/16</sup> "	25"	N/A	27 <sup>3/16</sup> "	12"	7"	10 <sup>5/8</sup> "	9 <sup>5/8</sup> "	106	33" x 34" x 33"	155