



AMERICAN EAGLE[®]
FOOD MACHINERY, INC.

AE-DDE30/36RFA
Fully Automatic
Hydraulic Powered
Dough Divider Rounder

773.376.0800 (P) • 773.376.2010 (F) • 3131 S. Canal St. Chicago, IL 60616

American Eagle® Fully Automatic Dough Divider Rounders Divides and Rounds Dough At The Push Of A Button! Industry Leading Design Translates Into Exceptional Reliability. Achieve Consistent, Quality Results With Minimal Training While Saving Time and Labor!

Quality Design

- 3-Phase Reliability And Powerful 3 HP Motor
- Dual Stage, Fully-Automatic Operation
- Unique Dual-Cam/Gear Driven Rounding Plate Design For Increased Rounding Stability That Produces Superior Results
- Strong Hydraulic-Powered Cutter Head With Food Grade Stainless Steel Cutting Knives
- Heavy Duty, Seamless Cast-Iron Body Lasts A Lifetime
- Self Lubricating Enclosed Transmission And Sealed Hydraulic System For Food Safety And Low Maintenance
- Quick-Disconnect Hydraulic Tubing Allows Machine Head To Tilt For Easier Cleaning
- Heat Treated Enamel White Finish Resists Rust, Scratches, And Dents



Scan QR Code
 To See Quick
 Video



Easy-To-Use Control Panel With Dual Timers To Set Pressing/Dividing and Rounding Times

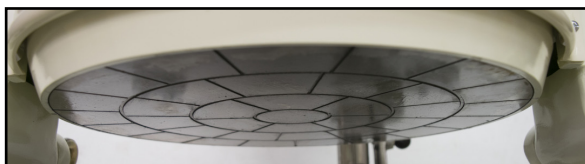

**Precision Dividing Head
 And Stainless Steel Knives**

Standard Features

- Adjustable Leveling Feet Provide Extra Stability Requires No Separate Anchoring For Installation
- Independent On/Off Switch And Reset Button
- Heavy Duty, 6 Foot Hard Wired Power Cable
- Easy Access Service Panels
- 1 Year Limited Warranty*

Standard Accessories

- Two (2) Divider-Rounder Plates

Proud Member of:

 North American Association of
 Food Equipment Manufacturers

Quality • Value • Reliability



AMERICAN EAGLE[®]
FOOD MACHINERY, INC.

AE-DDE30/36RFA
Fully Automatic
Hydraulic Powered
Dough Divider Rounder

sales@ameagle.biz • www.americaneaglemachine.com

American Eagle® Fully Automatic Dough Divider Rounder Machines Are Perfect For Supermarket Bakeries And Retail Bake Shops. They Are Easy To Operate And Handle A Variety Of Dough And Weights. Enjoy The Best Performance With Our Premium Design!

Specifications

Model	Motor	Voltage V/HZ/PH	Pieces Per Cut	Piece Weight Range	Batch Dough Weight	Productivity Pieces/Hour
AE-DDE30RFA	3 HP	220/60/3	30 Pieces	1.375 - 3.875 oz (40 - 110 g)	2.5 - 7.25 lbs (1200 - 3300 g)	6000-7000
AE-DDE36RFA	3 HP	220/60/3	36 Pieces	1.125 - 2.5 oz (32 - 70 g)	2.5 - 5.5 lbs (1150 - 2520 g)	6000-7000

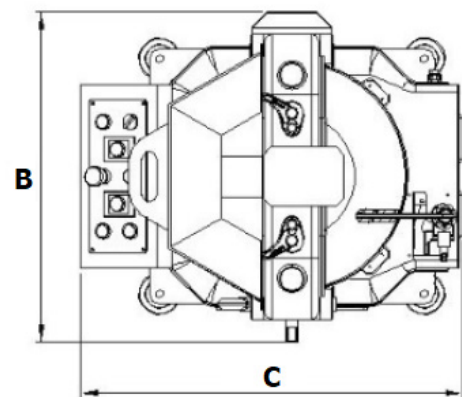
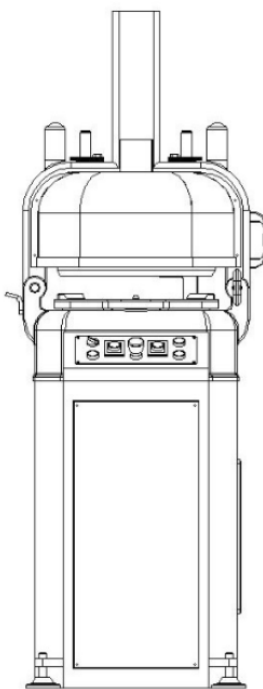
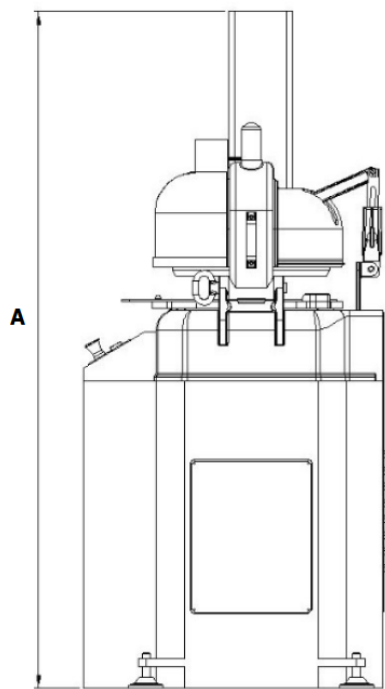

Measurements

Dimension	Inches	Centimeters
A	65.87	167.3
B	25.47	64.7
C	29.53	75

Dimensions and Shipping Information

Model	Overall Dimensions	Foot Print	Net Weight	Shipping Dimensions**	Ship Weight	Freight Class
AE-DDE30RFA	27"W x 29.3"L x 64" H	23"W x 23"D	950 lbs (431 kg)	33"W x 37"L x 69"H	1039 lbs (471 kg)	85
AE-DDE36RFA	27"W x 29.3"L x 64" H	23"W x 23"D	950 lbs (431 kg)	33"W x 37"L x 69"H	1039 lbs (471 kg)	85

*Warranty must be registered. Damage due to overloading, improper installation, or physical abuse voids warranty

**Crates are affixed to a skid (pallet). The weight and dimensions of this skid are included above and may vary from shipment to shipment.



Quality • Value • Reliability