

Project :	
Model # :	
Item # :	Qty :
Available W/H :	
Approval :	

## Sneeze Guard for JBT models

**Model : SNZ-C**

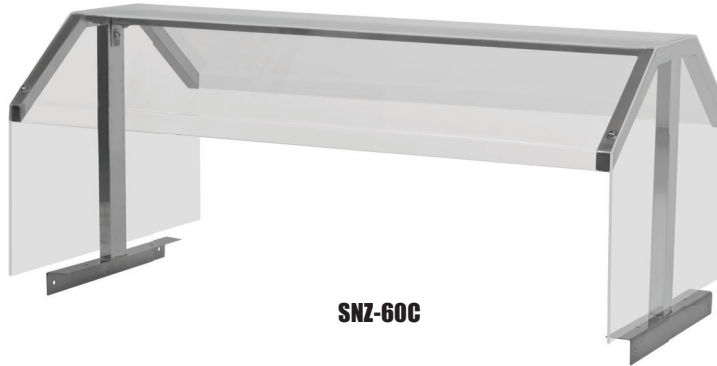

**SNZ-60C**

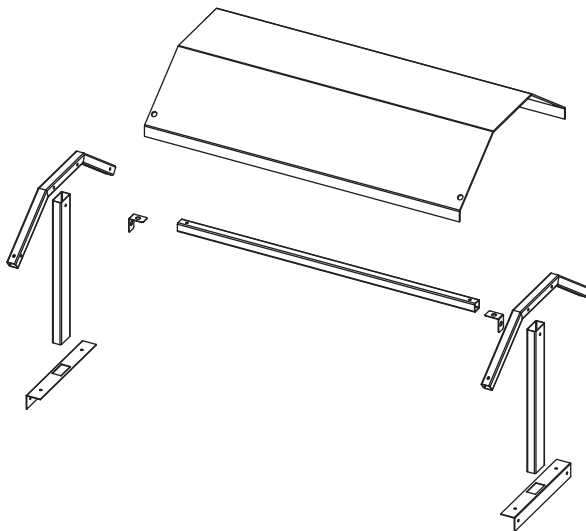

### ≡ FEATURES & BENEFITS ≡

- **Double sided sneeze guard keeps the food safe and protects the food area from germs and foreign objects**
- **A transparent acryl cover is durable and 304 stainless steel two side stands are easy to clean and anti-corrosive**
- **The package includes support brackets and mounting hardware (Except tools)**

(unit : inch)

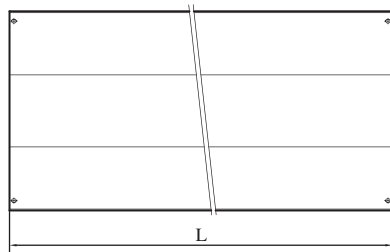

**COVER PLAN VIEW**

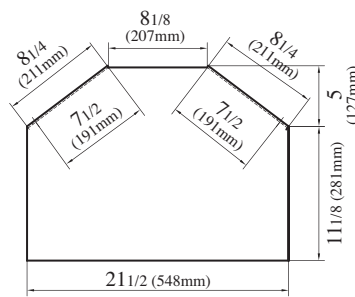

**COVER SIDE VIEW**

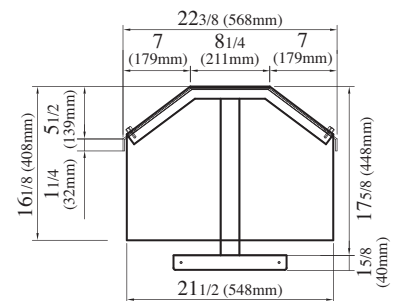

**STAND SIDE VIEW**

Model	L	D	H	Net Weight (lbs.)
SNZ-36C	35 3/8	22 3/8	20 3/4	20.9
SNZ-48C	47 1/2	22 3/8	20 3/4	25.3
SNZ-60C	59	22 3/8	20 3/4	29.7
SNZ-72C	70 7/8	22 3/8	20 3/4	33