

Simplify the collection of grease

Heated Grease Reservoir



The heated grease reservoir makes it possible to capture and manage all the grease produced from roasting throughout the day. It eliminates the need for a grease separator system.

The grease collection is done automatically during the roasting process. The rotisserie pumps grease into the heated grease reservoir for safe handling and disposal. The reservoir is heated to prevent the collected grease from solidifying. Quick disconnect makes it easy coupling to hook up to grease management systems. The heated grease can be pumped away easily. By eliminating the need to lift and carry grease collection pans, operators are able to save labor and improve safety.

Features Heated Grease Reservoir

Top features

- Designed to simplify the collection and transportation of grease
- Heated reservoir to prevent solidifying of collected grease
- Reduces maintenance and labor costs
- Improves operator safety
- Decreases oven downtime due to grease buildup
- Gives you the opportunity to generate revenue from grease
- Quick disconnect coupling to hook up to grease management systems

Standard characteristics

- Easy to use
- Grease is collected in a removable GN 1/1 pan
- Matching design for open underframe
- Perfect match with TDR 8 s AC and LDR 8 s AC



Perfect match with TDR 8 s AC and LDR 8 s AC open underframe

Fri-Jado Inc.
1401 Davey Road
Suite 100
Woodridge IL 60517
Toll free 877-374-5236
Fax 630-689-1424
e-mail us.info@frijado.com
www.frijado.com

HeatedGreaseReservoir-USA-082022.V2

Heated Grease Reservoir

Dimensions

Width	13 3/4"
Depth	27 1/8"
Height	14 1/8" - 26 3/4"

Technical data

Net weight	35.5 lbs
Gross weight	40 lbs
Voltage (wired into rotisserie)	24 V
Reservoir capacity	GN 1/1
Depth reservoir capacity	8"
Quick disconnect (grease removal)	Male 1/2"

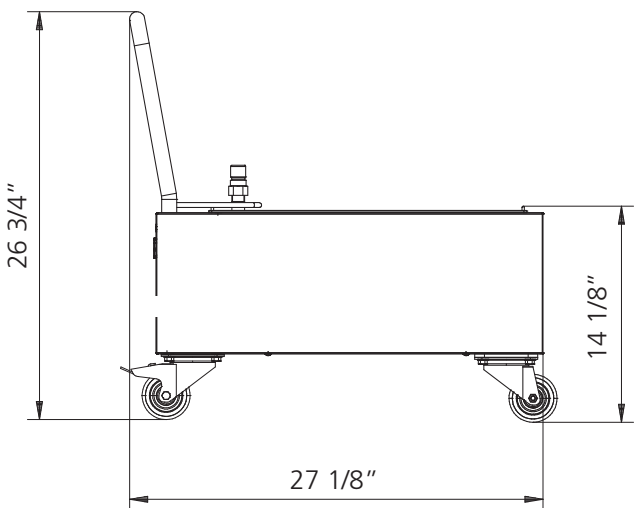
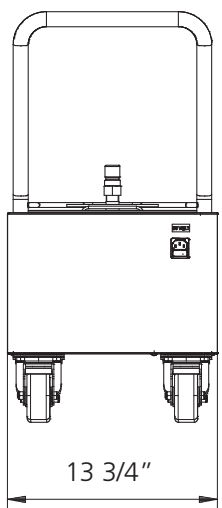
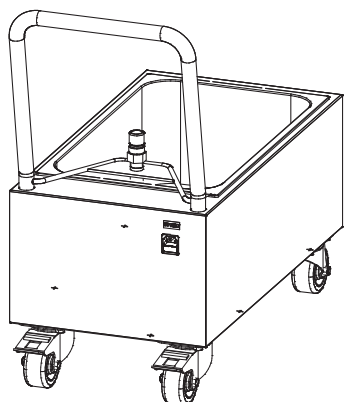
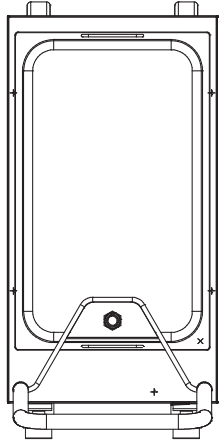

Specifications and technical data are subject to amendment without prior notice.

These are basic drawings. For more detailed technical information, please refer to the installation manual at www.frijado.com.



Fri-Jado Inc.
 1401 Davey Road
 Suite 100
 Woodridge IL 60517
 Toll free 877-374-5236
 Fax 630-689-1424
 e-mail us.info@frijado.com
www.frijado.com